

DigitalFlow™ DF868 Multipurpose Ultrasonic Liquid Flowmeter

Startup Guide (1- and 2-Channel)



GE
Measurement & Control

DigitalFlow™ DF868

Multipurpose Ultrasonic Liquid Flowmeter

Startup Guide (1- and 2-Channel)

910-176U Rev. E1
February 2016



www.gemeasurement.com

©2016 General Electric Company. All rights reserved.
Technical content subject to change without notice.

[no content intended for this page]

Information Paragraphs

Note: *These paragraphs provide information that provides a deeper understanding of the situation, but is not essential to the proper completion of the instructions.*

IMPORTANT: *These paragraphs provide information that emphasizes instructions that are essential to proper setup of the equipment. Failure to follow these instructions carefully may cause unreliable performance.*



CAUTION! This symbol indicates a risk of potential minor personal injury and/or severe damage to the equipment, unless these instructions are followed carefully.



WARNING! This symbol indicates a risk of potential serious personal injury, unless these instructions are followed carefully.

Safety Issues



WARNING! It is the responsibility of the user to make sure all local, county, state and national codes, regulations, rules and laws related to safety and safe operating conditions are met for each installation. The safety of any system incorporating the equipment is the responsibility of the assembler of the system.

Auxiliary Equipment

Local Safety Standards

The user must make sure that he operates all auxiliary equipment in accordance with local codes, standards, regulations, or laws applicable to safety.

Working Area



WARNING! Auxiliary equipment may have both manual and automatic modes of operation. As equipment can move suddenly and without warning, do not enter the work cell of this equipment during automatic operation, and do not enter the work envelope of this equipment during manual operation. If you do, serious injury can result.



WARNING! Make sure that power to the auxiliary equipment is turned OFF and locked out before you perform maintenance procedures on the equipment.

Qualification of Personnel

Make sure that all personnel have manufacturer-approved training applicable to the auxiliary equipment.

Personal Safety Equipment

Make sure that operators and maintenance personnel have all safety equipment applicable to the auxiliary equipment. Examples include safety glasses, protective headgear, safety shoes, etc.

Unauthorized Operation

Make sure that unauthorized personnel cannot gain access to the operation of the equipment.

Environmental Compliance

Waste Electrical and Electronic Equipment (WEEE) Directive

GE Measurement & Control is an active participant in Europe's *Waste Electrical and Electronic Equipment* (WEEE) take-back initiative, directive 2012/19/EU.

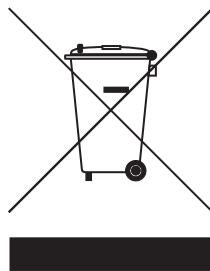

The equipment that you bought has required the extraction and use of natural resources for its production. It may contain hazardous substances that could impact health and the environment.

In order to avoid the dissemination of those substances in our environment and to diminish the pressure on the natural resources, we encourage you to use the appropriate take-back systems. Those systems will reuse or recycle most of the materials of your end life equipment in a sound way.

The crossed-out wheeled bin symbol invites you to use those systems.

If you need more information on the collection, reuse and recycling systems, please contact your local or regional waste administration.

Visit www.gemeasurement.com/environmental-health-safety-ehs for take-back instructions and more information about this initiative.

Chapter 1. Installation

1.1 Introduction 1

1.2 Unpacking 1

1.3 Site Considerations 2

 1.3.1 Electronics Console Location 2

 1.3.2 Flowcell Location 2

 1.3.3 Transducer Location 2

 1.3.4 Cable Lengths 2

 1.3.5 Temperature Transmitters..... 2

 1.3.6 Transducer Cables 3

1.4 Installing a Flowcell..... 3

1.5 Installing Temperature Transmitters 4

1.6 Mounting the DF868 Electronic Console 4

1.7 Making Electrical Connections 5

 1.7.1 Wiring the Line Power..... 5

 1.7.2 Wiring the Transducers 7

 1.7.3 Wiring the 0/4-20 mA Analog Outputs 7

 1.7.4 Wiring the Serial Port..... 7

 1.7.5 Wiring an Alarms Option Card 11

 1.7.6 Wiring a 0/4-20 mA Analog Inputs Option Card..... 12

 1.7.7 Wiring a Totalizer/Frequency Outputs Option Card 13

 1.7.8 Wiring an RTD Inputs Option Card 14

 1.7.9 Wiring a 0/4-20 mA Analog Outputs Option Card 14

 1.7.10 Wiring a MODBUS Option Card 14

Chapter 2. Initial Setup

2.1 Introduction.....17

2.2 Navigating Through the User Program17

2.3 Accessing the User Program18

 2.3.1 1-Channel Meter.....18

 2.3.2 2-Channel Meter.....18

2.4 Activating a Channel19

 2.4.1 1-Channel Meter.....19

 2.4.2 2-Channel Meter.....19

2.5 Entering System Data for a Channel.....19

 2.5.1 1-Channel Meter.....19

 2.5.2 2-Channel Meter.....20

 2.5.3 1- and 2-Channel Meters.....21

2.6 Entering Pipe Data24

 2.6.1 Transducer Number24

 2.6.2 Pipe Material25

 2.6.3 Pipe OD25

 2.6.4 Pipe Wall.....26

 2.6.5 Lining.....26

 2.6.6 Path and Axial Length.....26

 2.6.7 Tracking Windows.....26

 2.6.8 Fluid Type27

 2.6.9 Reynolds Correction28

 2.6.10 Calibration Factor28

2.7 Exiting the User Program29

Chapter 3. Operation

3.1 Introduction.....33

3.2 Powering Up33

3.3 Using the Display.....34

3.4 Taking Measurements35

 3.5.1 Foundation Fieldbus Communications.....37

Chapter 4. Specifications

4.1 General Specifications 39

 4.1.1 Hardware Configuration..... 39

 4.1.2 Environmental..... 39

 4.1.3 Flow Accuracy (Velocity)..... 39

 4.1.4 Range..... 39

 4.1.5 Rangeability..... 40

 4.1.6 Repeatability..... 40

 4.1.7 Energy Accuracy..... 40

 4.1.8 Fluid Types..... 40

4.2 Electrical Specifications..... 41

 4.2.1 Power Supply..... 41

 4.2.2 Power Usage..... 41

 4.2.3 Operating Modes..... 41

 4.2.4 European Compliance..... 41

 4.2.5 Hazardous (Classified) Location Compliance..... 41

 4.2.6 Input/Output Specifications..... 42

4.3 Operational Specifications..... 43

 4.3.1 Site Parameter Programming..... 43

 4.3.2 Data Logging..... 43

 4.3.3 Display Functions..... 43

 4.3.4 Printer Signal Output..... 43

4.4 Transducer Specifications..... 43

 4.4.1 Wetted Ultrasonic Flow Transducers..... 43

 4.4.2 Clamp-On Ultrasonic Flow Transducers..... 44

 4.4.3 Temperature Transducers..... 44

4.5 Pipe Size & Materials..... 45

 4.5.1 Wetted Transducers..... 45

 4.5.2 Clamp-On Transducers..... 45

4.6 PC Interface Software..... 45

Appendix A. CE Mark Compliance

A.1 Introduction..... 47

A.2 Wiring..... 47

A.3 External Grounding..... 47

Appendix B. Data Records

B.1 Option Cards Installed..... 49

B.2 Initial Setup Data..... 50

Appendix C. Optional Enclosures

C.1 Introduction.....55
C.2 Rack Mount Enclosure.....55
C.3 Rack Mount Wiring.....55
C.4 Rack Mount Front Panel.....56

Appendix D. Measuring P and L Dimensions

D.1 Measuring P and L.....61

Chapter 1. Installation

1.1 Introduction

To ensure safe and reliable operation of the Model DF868 Ultrasonic Liquid Flowmeter, the system must be installed in accordance with the guidelines established by GE engineers. Those guidelines, which are explained in detail in this chapter, include the following specific topics:

- Unpacking the Model DF868 system
- Selecting a suitable site for the electronics console and the flowcell/transducers
- Installing a flowcell
- Installing temperature transmitters
- Installing the Electronics Console
- Wiring the Electronics Console.

WARNING! The Model DF868 flowmeter can measure the flow rate of many liquids, some of which are potentially hazardous. In such cases, proper safety practices must be observed.

WARNING! Be sure to follow all applicable local safety codes and regulations for installing electrical equipment and working with hazardous liquids or flow conditions. Consult company safety personnel or local safety authorities to verify the safety of any procedure or practice.

ATTENTION EUROPEAN CUSTOMERS!

In order to meet CE Mark requirements, all wiring connections must be made in accordance with the instructions in Appendix A, *CE Mark Compliance*.

1.2 Unpacking

Carefully remove the electronics console, the transducers, and the cables from the shipping containers. Before discarding any of the packing materials, account for all components and documentation listed on the packing slip. The discarding of an important item along with the packing materials is all too common. If anything is missing or damaged, contact the factory immediately for assistance.

1.3 Site Considerations

Because the relative physical locations of the flowcell and the Model DF868 electronics console are important, use the guidelines given in this section to plan the Model DF868 system installation.

1.3.1 Electronics Console Location

The standard Model DF868 electronics enclosure is a Type-4X weather-resistant, dust-tight, indoor/outdoor type. Typically, the electronics console is mounted in a meter shed. When choosing a mounting site, make sure that the location permits easy access to the console for programming, testing, and servicing.

Note: *For compliance with the European Union's Low Voltage Directive (73/23/EEC), this unit requires an external power disconnect device such as a switch or circuit breaker. The disconnect device must be marked as such, clearly visible, directly accessible, and located within 1.8 m (6 ft) of the Model DF868.*

1.3.2 Flowcell Location

The pipeline flowcell consists of the flow transducers and any temperature transducers employed as part of the flowmeter system. Ideally, choose a section of pipe with unlimited access as the flowcell, such as a long stretch of pipe that is above ground. However, if the flowcell is mounted on an underground pipe, dig a pit around the pipe to facilitate installation of the transducers.

1.3.3 Transducer Location

For a given fluid and pipe, the Model DF868's accuracy depends primarily on the location and alignment of the transducers. In addition to accessibility, when planning for transducer location, adhere to the following guidelines:

1. Locate the transducers so that there are at least 10 pipe diameters of straight, undisturbed flow upstream and 5 pipe diameters of straight, undisturbed flow downstream from the measurement point. To ensure undisturbed flow, avoid sources of turbulence in the fluid such as valves, flanges, expansions and elbows.
2. Because sediment at the bottom of the pipe and gas at the top of the pipe may cause attenuation of the ultrasonic signal, locate the transducers on the side of a horizontal pipe, when possible. If limited pipe access necessitates top-mounted transducers and the sound beam path includes a reflection, shift the transducers to at least 10° off top center. This will minimize the influence of any sediment or gas on the reflected ultrasonic signals.

1.3.4 Cable Lengths

Locate the flowcell/transducers as close as possible to the electronics console. The factory supplies transducer cables up to 1,000 ft (306 m) in length. If longer cables are required, consult the factory for assistance.

1.3.5 Temperature Transmitters

When installing temperature transmitters in the flowcell, locate them downstream of the flow transducers. These transmitters should be positioned no closer to the flow transducers than 2 pipe diameters and no further away from the flow transducers than 20 pipe diameters.

1.3.6 Transducer Cables

When installing the transducer cables, always observe established standard practices for the installation of electrical cables. Specifically, do not route transducer cables alongside high amperage AC power lines or any other cables that could cause electrical interference. Also, protect the transducer cables and connections from the weather and corrosive atmospheres.

Note: *When using non-GE cables to connect the flow transducers to the Model DF868 electronics console, the cables must have electrical characteristics identical to the GE cables. Type RG 62 a/u coaxial cable should be used, and each cable must be the same length (within ± 4 in.).*

1.4 Installing a Flowcell

A flowcell is the section of pipe where the transducers are mounted. It can be created either by mounting the transducers on the existing pipeline or by mounting them on a spoolpiece. A spoolpiece is a separately manufactured pipe section, matched to the existing pipe, which contains ports for mounting the transducers. This approach allows the transducers to be aligned and calibrated before inserting the spoolpiece into the pipeline.

Figure 1 shows a diagram of a typical Model DF868 system. For detailed instructions on installing the transducers and/or spoolpiece, refer to the supplied drawings and the GE *Liquid Transducer Installation Guide* (916-055).

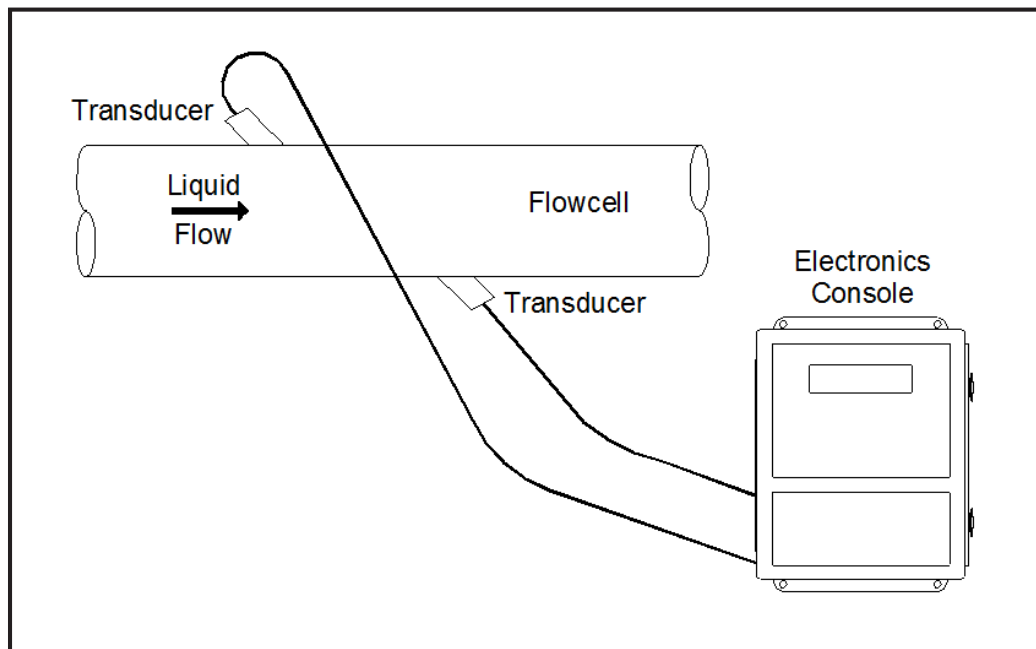

Figure 1: A Typical Model DF868 System

1.5 Installing Temperature Transmitters

Optional temperature transmitters may be installed as part of the flowcell, near the ultrasonic transducer ports. Be sure to observe the siting requirements given earlier in this chapter. These transmitters must use a 0/4-20 mA signal to transmit the temperature values to the Model DF868 electronics console. In turn, the electronics console will provide a 24 VDC signal to power the transmitters. Any desired transmitters or sensors may be used, but they must have an accuracy equal to 0.5% of the reading or better.

Note: *Resistive Thermal Devices (RTDs) are a good choice for measuring the temperature. If you use direct RTD inputs, you do not require transmitters.*

Typically, a 1/2" NPT female threaded port is used to mount the transmitters on the flowcell. If the pipeline is insulated, the coupling may need to be extended to provide convenient access. Of course, other types of mounting ports, including flanged ports, may be used for the transmitters.

Figure 2 shows a typical mounting arrangement for the pressure and temperature transmitters. The temperature sensor should protrude 1/4 to 1/2 way into the pipe.

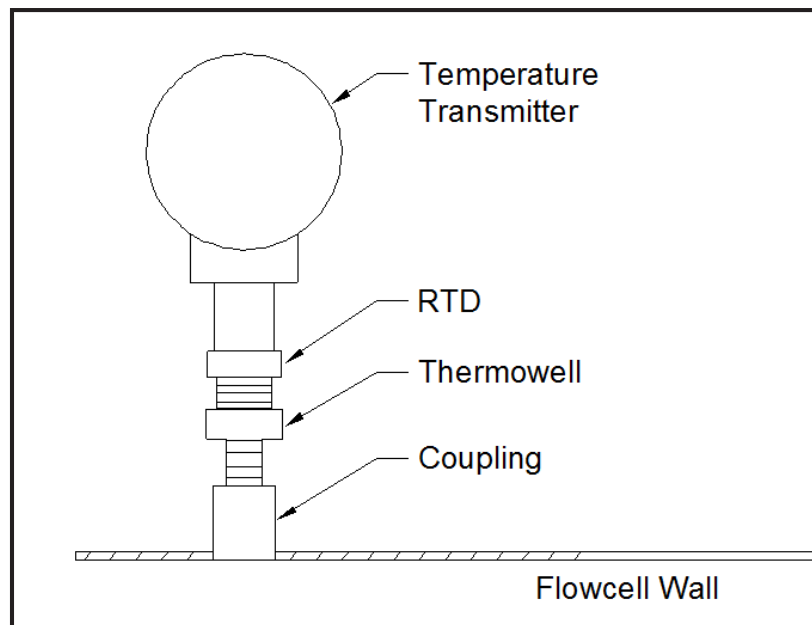

Figure 2: Typical Temperature Transmitter Mounting

1.6 Mounting the DF868 Electronic Console

The standard Model DF868 electronics package is housed in a NEMA-4X weather-resistant enclosure. Refer to Figure 9 on page 15 for the mounting dimensions of this enclosure. For meters housed in one of the optional enclosures, a dimensional drawing will be shipped with the unit.

IMPORTANT: *For meters supplied in one of the optional enclosure styles, refer to Appendix C, Optional Enclosures, for specific mounting dimensions and instructions.*

WARNING! Proper grounding of the DF868 chassis is required to prevent the possibility of electric shock. See Figure 10 on page 16 to locate the internal ground connection.

1.7 Making Electrical Connections

!ATTENTION EUROPEAN CUSTOMERS!

To meet CE Mark requirements, all cables must be installed as described in Appendix A, CE Mark Compliance.

This section contains instructions for making all the necessary electrical connections to the Model DF868 flowmeter. Refer to Figure 10 on page 16 for a complete wiring diagram of the unit.

IMPORTANT: *For meters supplied in one of the optional enclosure styles, refer to Appendix C, Optional Enclosures, for the appropriate wiring diagram and specific wiring instructions.*

Except for the power connector, all electrical connectors are stored in their terminal blocks during shipment and may be removed from the enclosure for more convenient wiring. Feed the cables through the conduit holes on the bottom of the enclosure, attach the wires to the appropriate connectors and plug the connectors back into their terminal blocks.

Note: *For compliance with the European Union's Low Voltage Directive (73/23/EEC), a transparent plastic shroud protects the electrical connections. The shroud must remain in place, except while wiring the unit. Reinstall the shroud after the wiring has been completed.*

Once the Model DF868 is completely wired, proceed to Chapter 2, *Initial Setup*, to configure the unit for operation.

1.7.1 Wiring the Line Power

!ATTENTION EUROPEAN CUSTOMERS!

To meet CE Mark requirements, all cables must be installed as described in Appendix A, CE Mark Compliance.

The Model DF868 may be ordered for operation with power inputs of 100-120 VAC, 220-240 VAC, or 12-28 VDC. The label on the shroud inside the electronics enclosure, just above the TB1 line power terminal block, lists the required line voltage and the fuse rating for the unit (the fuse rating is also listed in Chapter 4, *Specifications*). Be sure to connect the meter only to the specified line voltage.

Note: *For compliance with the European Union's Low Voltage Directive (2006/95/EC), this unit requires an external power disconnect device such as a switch or circuit breaker. The disconnect device must be marked as such, clearly visible, directly accessible, and located within 1.8 m (6 ft) of the Model D*

Note: *Only use Class 2 Rated Power supply for line power connection to DC instrument.*

Refer to Figure 3 on page 6 or Figure 10 on page 16 to locate terminal block TB1 and connect the line power as follows:

WARNING! Improper connection of the line power leads or connecting the meter to the incorrect line voltage will damage the unit. It will also result in hazardous voltages at the flowcell and associated piping and within the electronics console.

1.7.1 Wiring the Line Power (cont.)

1. Remove the plastic shroud that covers the terminal blocks. Be sure to reinstall the shroud after all of the wiring has been completed.
2. Strip $\frac{1}{4}$ " of insulation from the end of the power and neutral or line leads (or the positive and negative DC power leads), and $\frac{1}{2}$ " from the end of the ground lead.
3. Connect the ground lead to the internal ground connection located on the side panel of the enclosure (see Figure 3).

IMPORTANT: The incoming ground lead must be connected to the internal ground connection.

4. Connect the neutral or line lead (or the negative – DC power lead) to TB1-2 and the line power lead (or the positive + DC power lead) to TB1-3 as shown in Figure 3.

IMPORTANT: Do not remove the existing PC board ground wire or the cover ground wire.

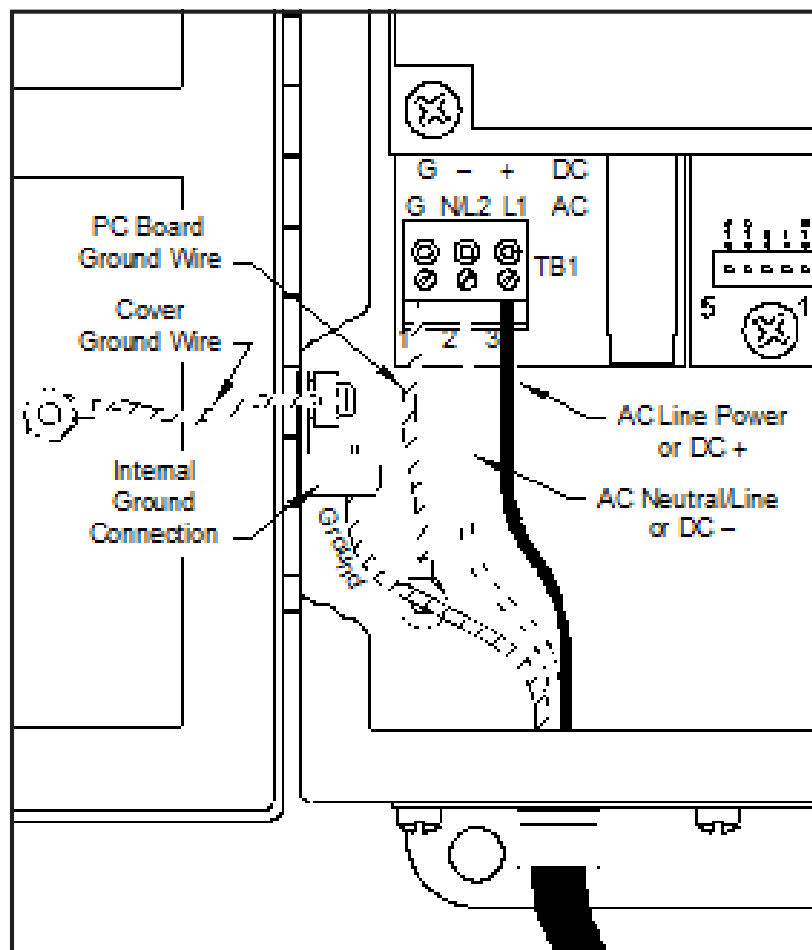

Figure 3: Wiring the Line Power

1.7.2 Wiring the Transducers

!ATTENTION EUROPEAN CUSTOMERS!
To meet CE Mark requirements, all cables must be installed as described in Appendix A,
CE Mark Compliance.

Wiring a typical Model DF868 ultrasonic liquid flowmeter system requires interconnection of the following components:

- a pair of transducers (per channel) mounted in the flowcell
- a lightning protector (optional)
- the electronics console

To wire the transducers, complete the following steps:

WARNING! Before connecting the transducers, take them to a safe area and discharge any static buildup by shorting the center conductor of the transducer cables to the metal shield on the cable connector.

1. If an optional lightning protector is being installed, connect it to the electronics end of the cables according to the instructions provided.
2. Locate the CH1 transducer cables and connect them to the two CH1 transducers.
3. Refer to the wiring diagram in Figure 10 on page 16 and connect the transducer cables to the CH1 terminal block. Then, secure the cable clamp.
4. For a 2-channel Model DF868 flowmeter, repeat steps 2-3 to wire the Channel 2 transducer system to terminal block CH2.

Note: *It is not required that Channel 2 of a 2-channel Model DF868 be used. This channel may be left inactive for future use.*

After the wiring has been completed, the transducer channel(s) must be activated before measurements can begin. See Chapter 2, *Initial Setup*, for instructions.

1.7.3 Wiring the 0/4-20 mA Analog Outputs

The standard configuration of the Model DF868 flowmeter includes two isolated 0/4-20 mA analog outputs (designated as A and B). Connections to these outputs may be made with standard twisted-pair wiring. The current loop impedance for these circuits must not exceed 550 ohms.

Refer to Figure 10 on page 16 for the location of terminal block I/O and wire the terminal block as shown.

1.7.4 Wiring the Serial Port

The Model DF868 is equipped with a built-in serial communications port. The standard port is an RS232 interface, but an optional RS485 interface is available upon request. Proceed to the appropriate sub-section for wiring instructions. For more information on serial communications, refer to the *EIA-RS Serial Communications Manual (916-054)*.

1.7.4a Wiring the RS232 Interface

Use the serial port to connect the Model DF868 flowmeter to a printer, an ANSI terminal or a personal computer. The RS232 interface is wired as Data Terminal Equipment (DTE), and the signals available at terminal block J1 are shown in Table 1. Refer to Figure 10 on page 16 and complete the following steps:

1. Disconnect the main power to the unit.
2. Install the required cable clamp in the chosen conduit hole on the side of the electronics enclosure.
3. Use the information in Table 1 to construct a suitable cable for connecting the Model DF868 to the external device. If desired, an appropriate cable may be purchased from the factory.

Table 1: RS232 Connection to DCE or DTE Device

J1 Pin	Signal Description	DCE DB25 Pin #	DCE DB9 Pin #	DTE DB25 Pin #	DTE DB9 Pin #
5	DTR (Data Terminal Ready)	20	4	20	4
6	CTS (Clear to Send)	4	7	5	8
7	COM (Ground)	7	5	7	5
8	RX (Receive)	2	3	3	2
9	TX (Transmit)	3	2	2	3

Note: *Signal names that imply direction (e.g., transmit and receive) are named from the point of view of the DTE device (the GE meter is usually considered the DTE device). When the RS232 standard is strictly followed, these signals are labeled with the same name and pin # on the DCE device side as well. Unfortunately, the convention is not followed because the DTE and DCE side get confused. Therefore, connections that imply direction are changed to reflect their direction on the DCE side.*

4. Feed the flying leads end of the cable through the conduit hole and wire it to terminal block J1. Connect the other end of the cable to the printer, ANSI terminal or personal computer, and secure the cable clamp.

After the wiring has been completed, consult the *User's Manual* for the external device to configure it for use with the Model DF868.

1.7.4b Wiring the RS485 Interface

Use the optional RS485 serial port to network multiple DF868 flowmeters to a single computer terminal. Upon request, the standard RS232 port on the DF868 may be configured as a two-wire, half-duplex RS485 interface, through a device such as the INMAC Model 800052 RS232-RS422/RS485 converter.

IMPORTANT: *The DF868 must be configured at the factory for RS485 operation.*

To wire the RS485 serial port, refer to Figure 10 on page 16 and complete the following steps:

1. Disconnect the main power to the unit.
2. Install the required cable clamp in the chosen conduit hole on the side of the electronics enclosure.

1.7.4b Wiring the RS485 Interface (cont.)

3. Feed one end of the cable through the conduit hole, wire it to terminal block J1 and secure the cable clamp. Connect the other end of the cable to the converter, as shown in Figure 4.

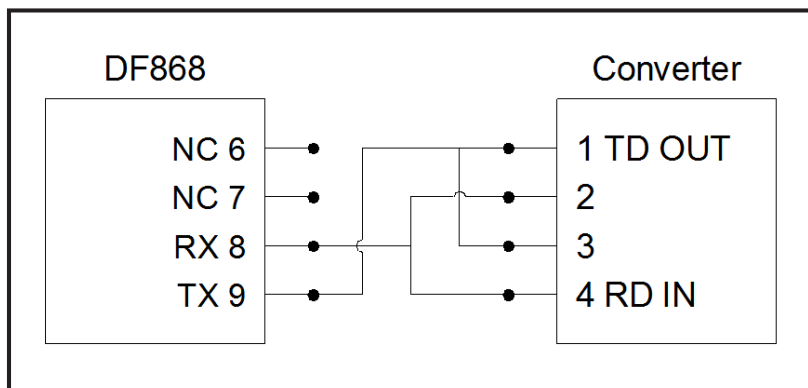

Figure 4: Typical RS485 Connections

1.7.4c Wiring the Ethernet Interface

A modified DF868 can use the Ethernet interface to communicate to an internal network. An optional Ethernet card with a unique MAC (IP) address (installed only in slots 5 or 6) includes an RJ45 connector. To connect the Ethernet-enabled DF868 to the network, insert the jack of an RJ45 cable into the RJ45 connector, route the cable through the bottom of the DF868, and wire the other end of the cable to the Ethernet network according to the manufacturer's instructions. An external connection is required between the Ethernet option card and the DF868's RS232 connector, as shown in Table 2.

Note: The MAC address for a specific DF868 is included with customer documentation. For more information on setting up the MAC address, refer to Chapter 6 of the Programming Manual.

Table 2: RS232 to Ethernet Interconnections

DF868 Type	Terminal Block	Terminal Block
Wall Mount	RS232 on Main Board	TB1 on Ethernet Card
	TX	Pin 1
	RX	Pin 2
Rack Mount	RTN	Pin 3
	RS232 on Main Board	TB2 on Ethernet Card
	TX	Pin 1
	RX	Pin 2
	RTN	Pin 3

1.7.4d Wiring the MODBUS/TCP Interface

Customers can also use a modified DF868 that provides a MODBUS/TCP interface to communicate to an internal network. An optional MODBUS/TCP card with a unique MAC (IP) address (installed only in slots 5 or 6) includes an RJ45 connector. To connect the MODBUS/TCP-enabled DF868 to the network, insert the jack of an RJ45 cable into the RJ45 connector, route the cable through the bottom of the DF868, and wire the other end of the cable to the Ethernet network according to the manufacturer's instructions.

Note: The MAC address for a specific DF868 is included with customer documentation. For more information on setting up the MAC address, refer to Chapter 6 of the Programming Manual.

1.7.4e Wiring the Foundation Fieldbus Network

Fieldbus network connections are made at J8/J9, pins 1 and 2 (see Figure 5). Optionally, a shield can be connected to J8/J9 pin 3, depending on the network wiring. Connector J8 or J9 will be installed depending on the option ordered by the customer.

No connections are made to J8/J9, pins 7 and 9, under normal operation. If it is desired to reset the network board to factory defaults:

1. Connect a jumper between J8/J9 pin 7 and pin 9.
2. Power cycle the instrument.
3. Ten seconds after the power has been restored to the unit, remove the jumper to return the network board to normal operation.

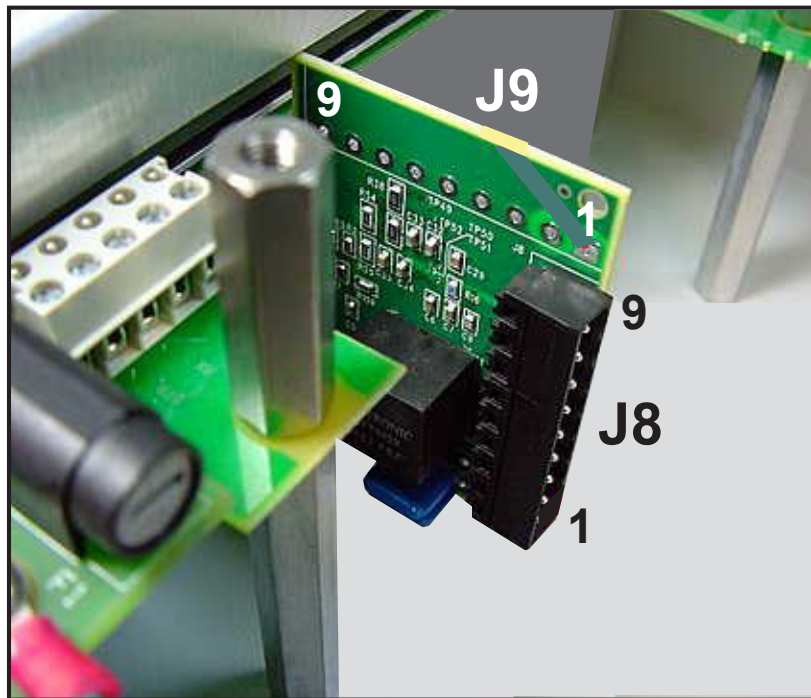

Figure 5: Network Connections - Standard Option Interior

1.7.5 Wiring an Alarms Option Card

The Model DF868 flowmeter can accommodate up to 4 alarm option cards. Each alarm option card includes three *Form C* relays (designated as A, B and C).

The alarm relays on the option card are available in two types:

- general purpose
- hermetically sealed for Class I, Division 2 hazardous areas.

The maximum electrical ratings for the relays are listed in Chapter 4, *Specifications*. Each of the three alarm relays can be wired either as *Normally Open* (NO) or *Normally Closed* (NC).

In setting up an alarm relay, it may be wired for either *conventional* or *fail-safe* operation. In fail-safe mode, the alarm relay is constantly energized, except when it is triggered or a power failure or other interruption occurs. See Figure 6 for the operation of a NO alarm relay in both conventional and fail-safe mode.

Connect the two wires required for each alarm relay in accordance with the pin number assignments shown in Figure 10 on page 16.

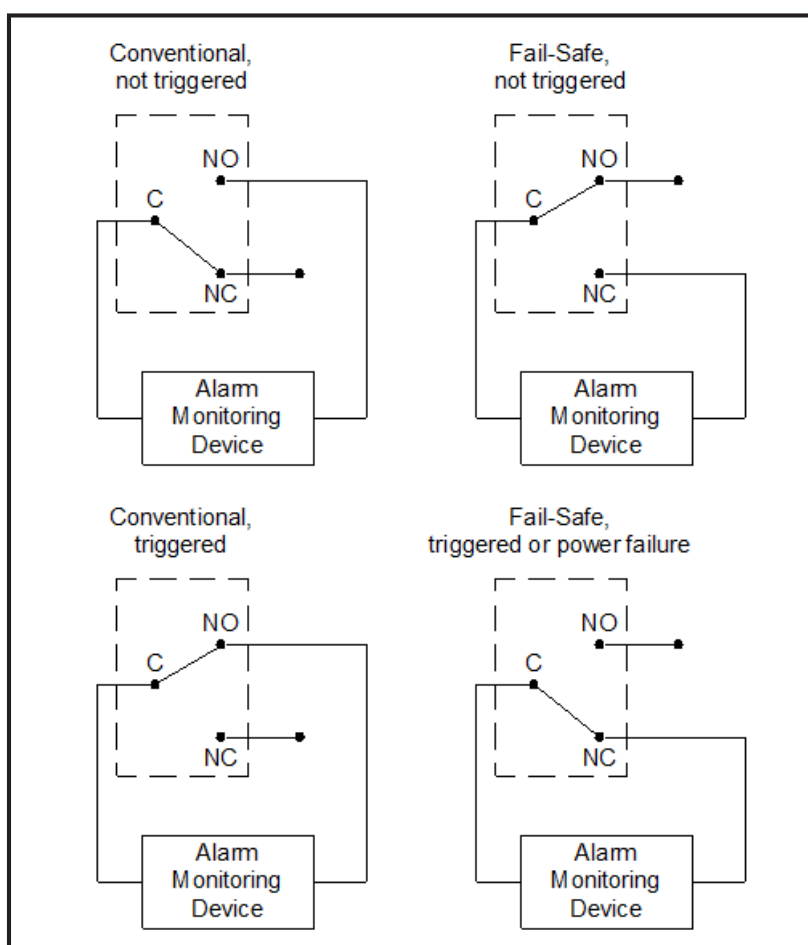

Figure 6: Conventional and Fail-Safe Operation

1.7.6 Wiring a 0/4-20 mA Analog Inputs Option Card

To calculate energy measurement, the Model DF868 requires accurate *temperature data* from the measurement site. Transmitters installed in the flowcell can provide this information via an optional 0/4-20 mA analog inputs card. This option card includes two isolated 0/4-20 mA analog inputs (designated as A and B), each of which includes a 24 VDC power supply for loop-powered transmitters. Either input may be used to process the temperature signal.

Note: *To enter programming data during operation of the meter, it will be necessary to know which input is assigned to which process parameter. This information should have been entered in Appendix B, Data Records.*

The analog inputs, which have an impedance of 118 ohms, should be connected with standard twisted-pair wiring. Power to the transmitters may be supplied either by the integral 24 VDC power supply on the analog input card or by an external power supply. Figure 7 shows typical wiring diagrams, with and without an external power supply, for one of the analog inputs.

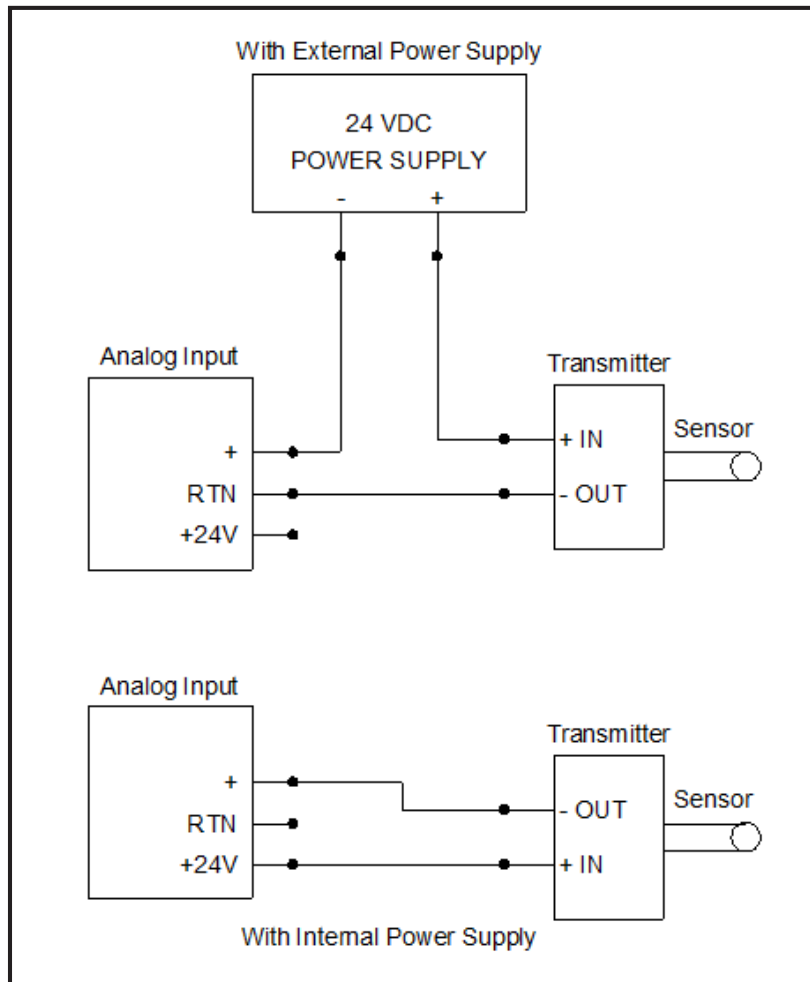

Figure 7: Analog Input Wiring Diagram

1.7.6 Wiring a 0/4-20 mA Analog Inputs Option Card (cont.)

Wire the analog input terminal block in accordance with the pin number assignments shown in Figure 10 on page 16.

If the flowmeter system includes additional transmitters, the Model DF868 can accommodate up to three more analog inputs option cards. These option cards are identical to the temperature card described on page 12 and they should be wired in the same manner (see Figure 10 on page 16).

The analog inputs on the option card(s) can be calibrated with the Model DF868's built-in analog outputs. However, be certain that the analog outputs have been calibrated first. See Chapter 1, *Calibration*, in the *Service Manual* for the appropriate procedures.

1.7.7 Wiring a Totalizer/Frequency Outputs Option Card

The Model DF868 can accommodate up to four totalizer/frequency outputs option cards. Each totalizer/frequency outputs option card provides four outputs (designated as A, B, C, and D) that can be used as either totalizer or frequency outputs.

Each totalizer/frequency output requires two wires. Wire this terminal block in accordance with the pin number assignments shown in Figure 10 on page 16. Figure 8 shows sample wiring diagrams of a totalizer output circuit and a frequency output circuit.

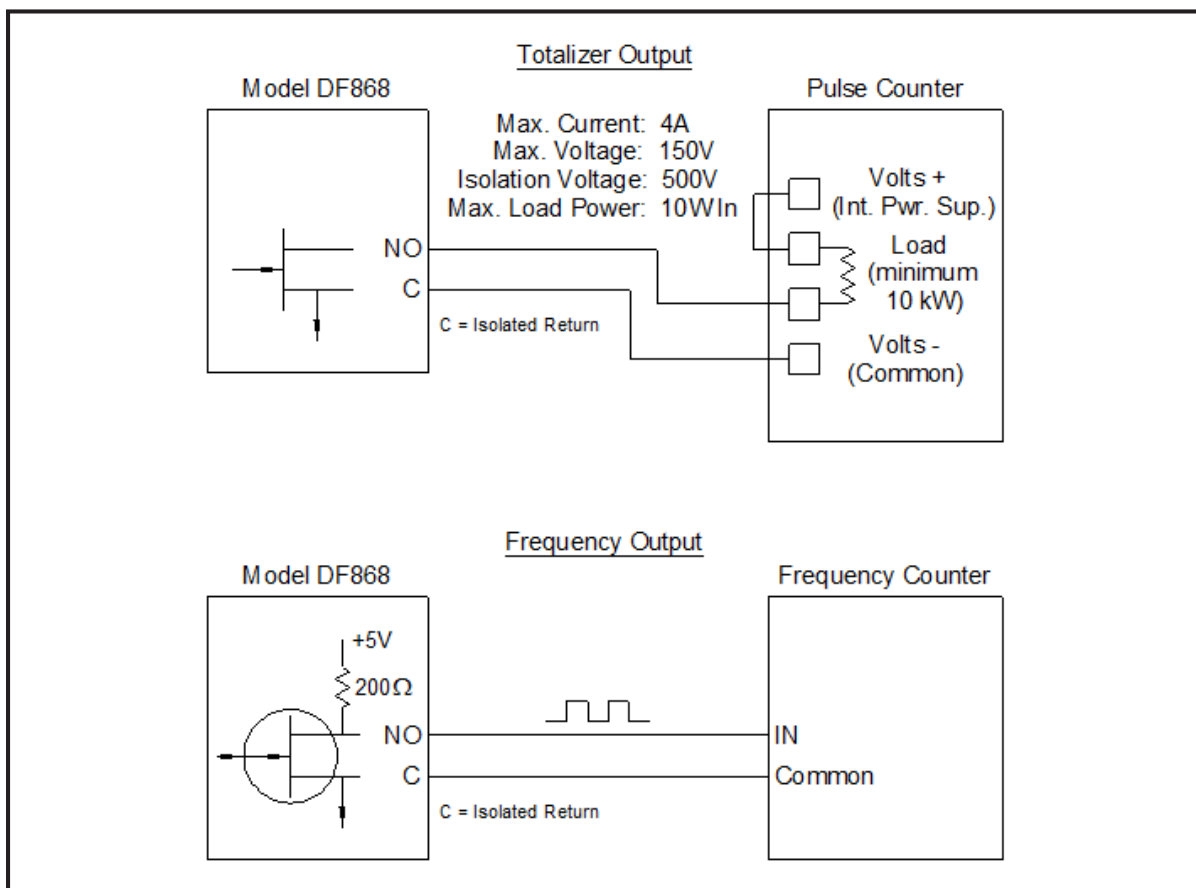

Figure 8: Totalizer/Frequency Outputs Wiring

1.7.8 Wiring an RTD Inputs Option Card

The Model DF868 can accommodate up to four RTD (Resistance Temperature Device) inputs option cards. Each RTD inputs option card provides two direct RTD inputs (designated as A and B).

Each RTD input requires three wires, which should be fed through one of the conduit holes on the bottom of the electronic console. (For maximum accuracy, the three wires must be of equal length.) Wire this terminal block in accordance with the pin number assignments shown in Figure 10 on page 16.

1.7.9 Wiring a 0/4-20 mA Analog Outputs Option Card

The Model DF868 flowmeter can accommodate up to 4 analog outputs option cards. Each analog outputs option card includes four isolated 0/4-20 mA outputs (designated as A, B, C and D).

Connections to these outputs may be made with standard twisted-pair wiring. The total current loop impedance for these circuits must not exceed 1000 ohms. Wire this terminal block in accordance with the pin number assignments shown in Figure 10 on page 16.

1.7.10 Wiring a MODBUS Option Card

A modified DF868 can use the RS485 standard for MODBUS communications. This standard allows up to 32 nodes (drivers and receivers) on one multidrop network, at distances up to 4,000 ft (1,200 m). To connect the instrument(s) to the host system, the factory recommends using a 24-gauge (24 AWG) twisted-pair cable with a characteristic impedance of 120 ohms and a 120-ohm termination at each end of the communications line.

The MODBUS option card must be plugged into either slot 5 or slot 6 of the DF868. On the option card, pin 1 is the [TMT-] inverting or negative connection and pin 2 is the [TMT+] non-inverting or positive connection. To link the DF868 to the control system, connect the two wires of the twisted-pair cable from these terminals to the corresponding terminals at the control system, in accordance with the pin number assignments shown in Figure 10 on page 16.

Note: *If two MODBUS option cards are installed in the DF868, only the card in slot 5 is activated.*

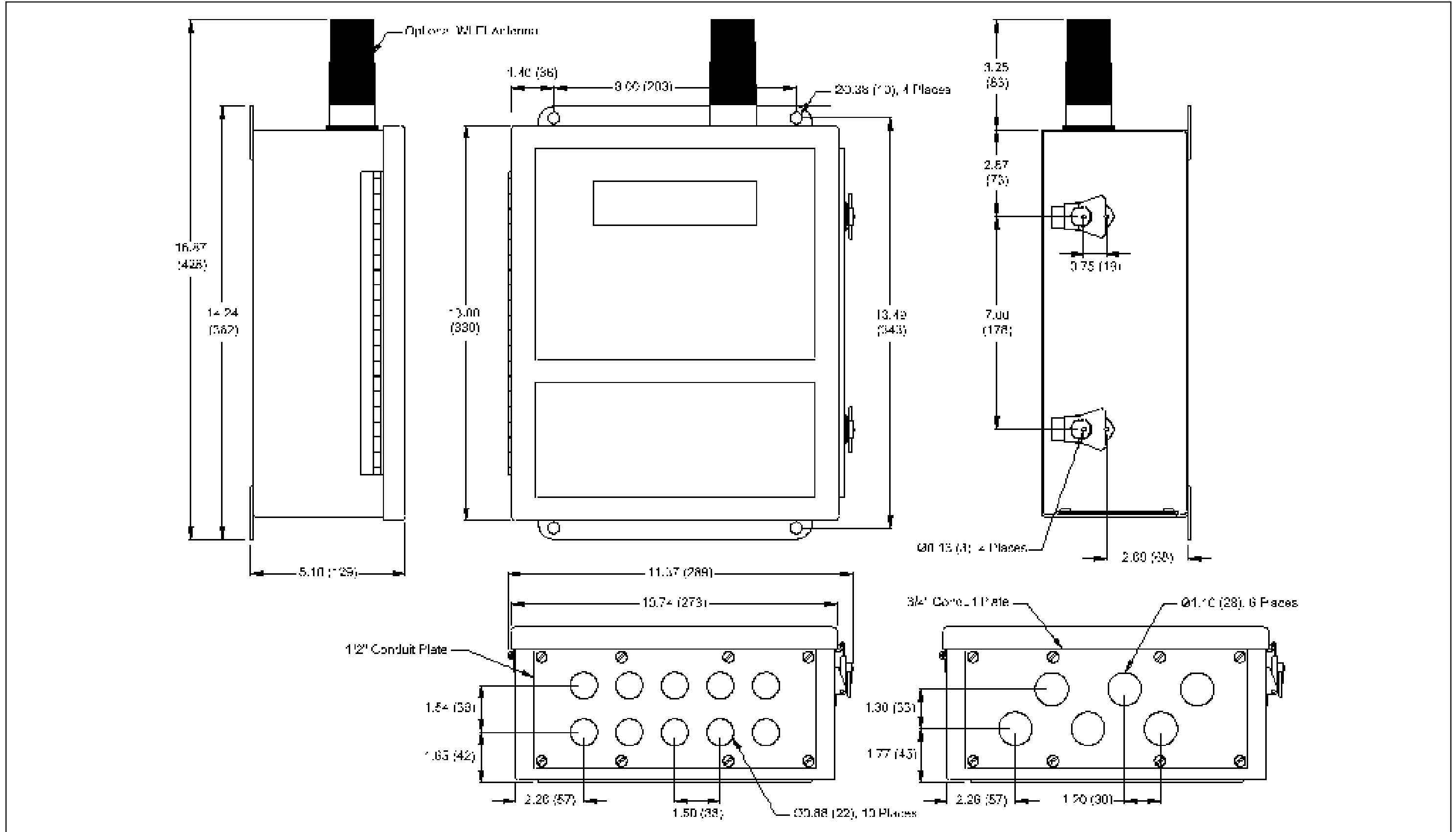

Figure 9: Model DF868 Type 4X Enclosure (ref. dwg #425-208)

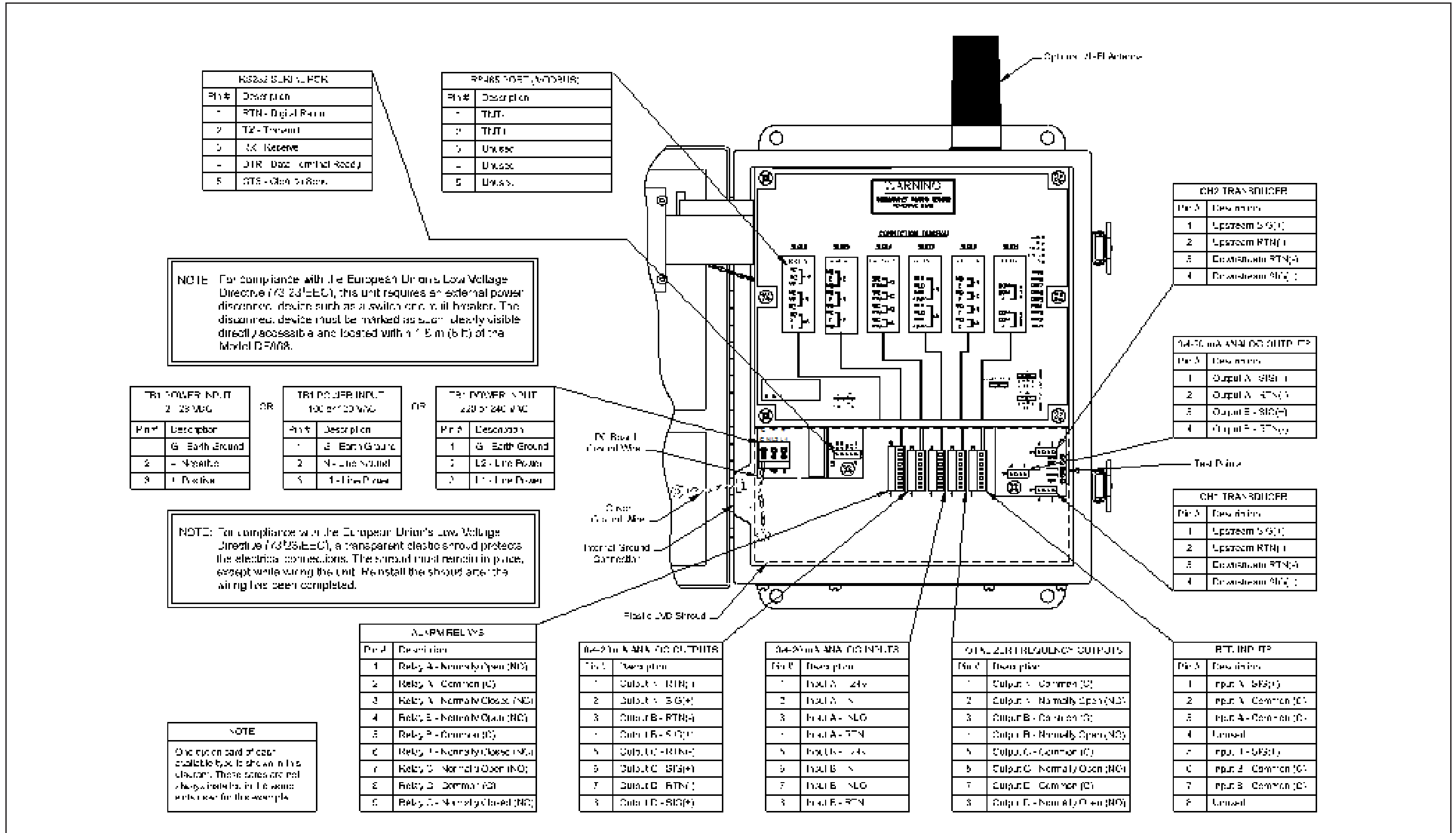

Figure 10: Model DF868 Electronics Console Wiring (ref. dwg #702-213, sht 1 of 2)

Chapter 2. Initial Setup

2.1 Introduction

This chapter provides instructions for entering the minimum amount of programming data required to place the Model DF868 flowmeter into operation. Before the Model DF868 can begin taking measurements and displaying valid data, the system and pipe parameters must be entered. In addition, if you plan to use both channels of a 2-channel meter, each channel must be activated prior to use. Additional programming options provide access to the more advanced features of the Model DF868, but this information is not required to begin taking measurements.

Note: *See the Programming Manual for information on those User Program options not covered in this chapter.*

2.2 Navigating Through the User Program

In order to begin using the Model DF868, the following submenus within the *User Program* will be accessed:

- ACTIV - enables selection of the desired measurement method (for a 2-Channel meter, it is also used to activate a channel)
- SYSTM - prompts the user to enter the required system data
- PIPE - prompts the user to enter the required pipe parameters

As a guide in following the programming instructions in this chapter, the relevant portions of the Model DF868 menu map have been reproduced in Figure 11 on page 31 and Figure 12 on page 32.

Note: *There are minor differences at the start of the ACTIV and SYSTM submenus for the 1-Channel and 2-Channel models, but the PIPE submenus are identical.*

The following discussion assumes that the left screen pane is active. If the right screen pane is active, only the function key designations change. That is, replace [F1]-[F4] with [F5]-[F8]. Be sure to record all programming data in Appendix B, *Data Records*.

Use the keypad, as described in the *Programming Manual*, to navigate through the *User Program*. The menu map may be followed in sequence, or the [*f*] and [←] keys may be used to scroll through the prompt screens. The [♦] key may be used to delete the last alphanumeric character that was entered from the keypad.

2.3 Accessing the User Program

To access the *User Program*, press the [PROG] key on the keypad.

Note: *If the security feature is active, enter the password and press [ENT] to enter the User Program. See the SECUR submenu section in Chapter 1 of the Programming Manual for more information on the security feature.*

2.3.1 1-Channel Meter

For a 1-Channel Model DF868, the measurement mode screen is replaced by the following initial programming mode screen:

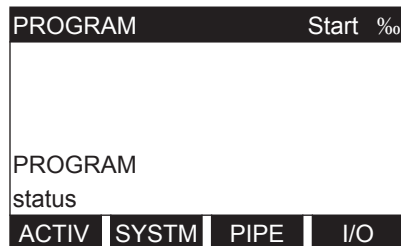

At the *User Program* screen shown, press [F1] and proceed to the next page for instructions.

2.3.2 2-Channel Meter

For a 2-Channel Model DF868, the following two-step sequence is required to reach the initial programming screen:

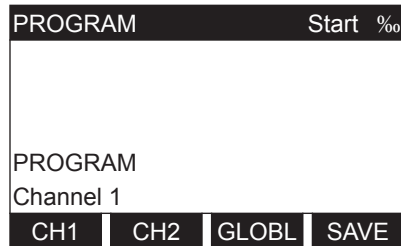

Press [F1] or [F2] to select the submenu for Channel 1 or Channel 2, respectively, from the option bar.

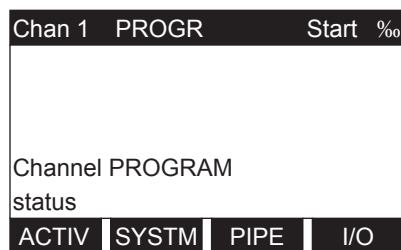

At the *User Program* screen shown, press [F1] and proceed to the next page for instructions.

Only the submenus ACTIV, SYSTM and PIPE are discussed in this manual. Refer to the *Programming Manual* for information on the other submenus.

Note: *In this manual, only the programming of Channel 1 will be described. To program Channel 2, simply repeat the same procedures presented for Channel 1.*

2.4 Activating a Channel

The ACTIV submenu permits selection of the desired measurement method. In addition, it is used to activate/deactivate one or both of the channels in a 2-Channel Model DF868.

2.4.1 1-Channel Meter

1. Enter the ACTIV submenu by pressing [F1] at the User PROGRAM prompt.
2. Press [F1] to activate the channel in Transit-Time mode, or [F2] to activate the channel in TransFlection mode.

2.4.2 2-Channel Meter

1. Enter the ACTIV submenu by pressing [F1] at the Channel PROGRAM prompt.
2. Press [F1] (Off) to deactivate the channel and return to the Channel PROGRAM prompt, or press [F2] to activate the channel in Transit-Time mode, or [F3] to activate TransFlection mode.

Note: *If a customer has not ordered the DF868 with TransFlection mode, the TRNFL option does not appear.*

Proceed directly to the next section to program the SYSTM submenu.

2.5 Entering System Data for a Channel

Begin the programming of the SYSTM submenu in either the *1-Channel* or *2-Channel* section below.

2.5.1 1-Channel Meter

For the 1-Channel Model DF868, the information entered in the SYSTM submenu pertains to the global operation of the flowmeter.

1. At the *User Program* screen, press the [F2] function key to program the SYSTM submenu.
2. Enter a *Site Label* of up to 9 characters and press the [ENT] key. (While taking measurements, the site label appears on the locator bar.)
3. Enter a *Site Message* of up to 21 characters. Use this screen to enter a brief description of the site. When the message has been entered, press the [ENT] key.
4. Press [F1] to turn the *Energy Option* OFF or press [F2] to turn it ON. (The Energy Option calculates the energy of a system based on temperatures at the supply and return points, and the flow of fluid.)
5. To select the *System Units*, press [F1] to display parameters and measurements in English units or press [F2] to display parameters and measurements in Metric units.
6. To program the *Totalizer Option*, press [F1] to measure totals automatically, or press [F2] to measure totals manually.

The remainder of the SYSTM submenu is identical for the 1-Channel and 2-Channel versions of the Model DF868. Proceed to the *1- and 2-Channel Meters* section to complete the programming of this submenu.

2.5.2 2-Channel Meter

For the 2-Channel Model DF868, the information entered in the SYSTM submenu pertains only to the currently selected channel.

1. At the *User Program* screen shown, press [F2] to program the SYSTM submenu.
2. Enter a *Channel Label* of up to 9 characters. While taking measurements, the channel label will appear on the locator bar. Press [ENT].
3. Enter a *Channel Message* of up to 21 characters. Press [ENT].
4. Press [F1] to turn the Energy Option **OFF** or press [F2] to turn it **ON**. (The Energy Option calculates the energy of a system based on temperatures at the supply and return points, and the flow of fluid.)

Note: *For the 2-Channel Model DF868, the System Units and Totalizer prompts, which are not required to make the unit operational, are located in the GLOBL submenu. See the Programming Manual for details.*

The remainder of the SYSTM submenu is identical for the 1-Channel and 2-Channel versions of the Model DF868. Proceed to the *1- and 2-Channel Meters* section below to complete programming.

2.5.3 1- and 2-Channel Meters

1. Use the [F1]-[F4] and [Ø] keys to select the desired *Volumetric Units* for the flow rate display.

The abbreviations and definitions of all the available volumetric units are shown in Table 3. The choices shown on the option bar are determined by the selections made at the previous SYSTEM UNITS prompt screen.

Table 3: Volumetric Unit Options

English Volumetric Units	Metric Volumetric Units
GAL/S - U.S. Gallons per Second	L/S - Liter per Second
GAL/M - U.S. Gallons per Minute	L/M - Liters per Minute
GAL/H - U.S. Gallons per Hour	L/H - Liters per Hour
MGD - Millions of U.S. Gallons per Day	ML/D - Millions of Liters per Day
ft ³ /s - Cubic Feet per Second	m ³ /s - Cubic Meters per Second
ft ³ /m - Cubic Feet per Minute	m ³ /m - Cubic Meters per Minute
ft ³ /h - Cubic Feet per Hour	Mm ³ /h - Millions of Cubic Meters per Hour
Mft ³ /d - Millions of Cubic Feet per Day	Mm ³ /d - Millions of Cubic Meters per Day
BBL/S - Barrels per Second	BBL/S - Barrels per Second
BBL/M - Barrels per Minute	BBL/M - Barrels per Minute
BBL/H - Barrels per Hour	BBL/H - Barrels per Hour
BBL/D - Barrels per Day	BBL/D - Barrels per Day
MBBL/D - Millions of Barrels per Day	MBBL/D - Millions of Barrels per Day
Acre-inch/sec - Acre-inches per second	N/A
Acre-inch/min - Acre-inches per minute	N/A
Acre-inch/hr - Acre-inches per hour	N/A
Acre-inch/day - Acre-inches per day	N/A
Acre-foot/sec - Acre-feet per second	N/A
Acre-foot/min - Acre-feet per minute	N/A
Acre-foot/hr - Acre-feet per hour	N/A
Acre-foot/day - Acre-feet per day	N/A

2. Press [F1]-[F4] to select the *Vol Decimal Digits* (the desired number of digits to the right of the decimal point) in the volumetric flow rate display.
3. Use the [F1]-[F4] and [Ø] keys to select the *Totalizer Units*.

The abbreviations and definitions of all the available totalizer units are shown in Table 4 on page 22. The choices shown on the option bar in the prompt screen above are determined by the selections made at the previous SYSTEM UNITS prompt screen.

2.5.3 1- and 2-Channel Meters (cont.)

Table 4: Totalizer Unit Options

English Totalizer Units	Metric Totalizer Units
Gal - U.S. Gallons	L - Liters
MGAL - Mega U.S. gallons	ML - Megaliters
ft ³ - Cubic Feet	m ³ - Cubic Meters
Mft ³ - Mega Cubic Feet	Mm ³ - Mega Cubic Meters
BBL - Barrels	BBL - Barrels
MBBL - Megabarrels	MBBL - Megabarrels
Acre-inches	
Acre-feet	

- Press [F1]-[F4] to select the *Total Decimal Digits* (the digits to the right of the decimal point) in the totalized flow display.

2.5.3a Mass Flow

If the Mass Flow prompt in the SETUP submenu is not enabled, skip this sub-section. However, the following programming sequence appears if Mass Flow is enabled.

- Use the [F1]-[F4] keys to select the desired *Mass Flow* units, listed in Table 5.

Table 5: Available Mass Flow Units

English	Metric
LB = Pounds	KG = Kilograms
KLB = Thousands of LB	TONNE = Metric Tons (1000 KG)
MMLB = Millions of LB	
TONS = Tons (2000 LB)	

- Use the [F1]-[F4] keys to select the desired *Mass Flow Time* units.
- Use the [F1]-[F4] keys to select the *MDOT Decimal Digits* (the digits to the right of the decimal point) for displaying mass flow.
- Use the [F1]-[F4] keys to select the *Mass (Totalizer)* units, listed in Table 5.
- Use the [F1]-[F4] keys to select the *Mass Decimal Digits* (the digits to the right of the decimal point) for displaying totalized mass flow.

2.5.3b Energy Option

If you did not select the Energy Option earlier, the meter now returns to the initial *User* (or *Channel*) *Program* screen. But if you selected the Energy Option, several more prompts appear.

1. Use the [F1]-[F4] keys to select the desired *Power* units, listed in Table 6.

Table 6: Power Unit Options

English Power Units	Metric Power Units
kBTU—Thousands of British Thermal Units per Hour	kCAL/sec—Kilocalories/second
MMBTU—Millions of British Thermal Units per Hour	MCAL/sec—MegaCalories/second
kW—kilowatts	kW—kilowatts
Tons	MW—Megawatts

2. Use the [F1]-[F4] keys to select the *Power Decimal Digits* (the digits to the right of the decimal point) for displaying power.
3. Use the [F1]-[F4] keys to select the *Total Energy* units, shown in Table 7.

Table 7: Energy Unit Options

English Energy Units	Metric Energy Units
kBTU—Thousands of British Thermal Units	kCAL—Kilocalories
MMBTU—Millions of British Thermal Units	MCAL—MegaCalories
kWHr—Kilowatt-Hours	kW—Kilowatt-Hour
Tons	MW—Megawatt-Hour

4. Use the [F1]-[F4] keys to select the *Energy Decimal Digits* (the digits to the right of the decimal point) for displaying total energy.
5. Press [F1] to make measurements in a *Cooling* system, or [F2] to make measurements in a *Heating* system.
6. Press [F1] to conduct *Flow Measurement* at the point of return (where the liquid exits), or [F2] to measure flow at the point of supply (where the liquid enters).

When the above selection has been made, the meter exits the SYSTM submenu and returns to the initial *User Program* screen. Proceed directly to the next section to program the PIPE submenu.

2.6 Entering Pipe Data

The PIPE submenu permits entry of the transducer and pipe specifications. To program this menu, complete the following steps:

1. At the *User (or Channel) Program* screen, press [F3] to program the PIPE submenu.

2.6.1 Transducer Number

2. Enter the *Transducer Number* engraved on the head of the transducer and press [ENT]. If there is no engraved number, complete the steps below. Otherwise, proceed to step 3 on the next page for a clamp-on transducer, or to step 4 for a wetted transducer.

IMPORTANT: *Special transducers, which have no engraved number on the head, are rarely used. Examine the transducer head carefully for a number.*

- a. Assign a number between 91 and 99 to the *Special Transducer* and press [ENT]. (The meter will only accept values from 1 to 199.)
- b. Use the [F1]-[F3] keys to select the *Wedge Type*. Three choices are available: Rayleigh or Shear wave (for clamp-on transducers) or wetted transducers.
- c. Use the [F1]-[F3] keys to select the *Frequency* of the special transducer.

IMPORTANT: *The frequency is required to transmit an excitation voltage at the transducer's natural frequency.*

- d. Enter the special transducer *Time Delay (Tw)* value supplied by the factory and press [ENT].

Note: *Tw is the time required for the transducer signal to travel through the transducer and its cable. This time delay must be subtracted from the transit times of the upstream and downstream transducers to ensure an accurate measurement.*

If you have selected a special wetted transducer, the meter now rejoins the standard programming sequence. However, if you have selected a special clamp-on transducer, two additional prompts appear.

- e. Use the numeric keys to enter the *Wedge Angle* (the angle of the ultrasonic transmission) in degrees and press [ENT].

Note: *In TransFlection mode, you must enter a separate wedge angle for both the transmit transducer and the receive transducer.*

- f. Use the numeric keys to enter the *Wedge Soundspeed* in ft/sec or m/sec and press [ENT].

2.6.2 Pipe Material

3. Use the [F1]-[F4] and [∅] keys to select the *Pipe Material*, as listed in Table 8.

Table 8: Pipe Materials

Pipe Material Category	Specific Material
Steel	Carbon Steel or Stainless Steel
Iron	Ductile Iron or Cast Iron
Cu - Copper	None
Al - Aluminum	None
Brass	None
CuNi - Copper/Nickel	70% Cu 30% Ni or 90% Cu 10% Ni
Glass	Pyrex, Flint, or Crown
Plastic	Nylon, Polyester, Polypropylene, PVC (CPVC), Acrylic
Other*	Any material

Note: Depending on the pipe material choice, another window may appear, asking you to specify the specific material. If you have selected “Other,” the DF868 prompts you to enter the sound speed.

2.6.3 Pipe OD

4. Enter the known *Pipe OD* or circumference and press [F1]-[F4] to select the appropriate units, as shown in Table 9. Press [ENT]. (The meter will only accept values from 1/8 to 648 in.)

Note: The first two lines of text in the prompt area depend on the selection made at the TRANSDUCER NUMBER prompt. The option bar choices may appear in English or Metric units.

Obtain the required information by measuring either the pipe outside diameter (OD) or circumference at the transducer installation site. The data may also be obtained from standard pipe size tables.

Table 9: Available Pipe OD Units

English	Metric
inch = pipe OD in inches	mm = pipe OD in millimeters
feet = pipe OD in feet	m = pipe OD in meters
in/PI = pipe circumference in inches	mm/PI = pipe circumference in millimeters
ft/PI = pipe circumference in feet	m/PI = pipe circumference in meters

2.6.4 Pipe Wall

5. Enter the known thickness of the *Pipe Wall*, in the same units used for the pipe OD, and press [ENT].

IMPORTANT: *Because the units can not be independently chosen for this parameter, the value must be entered in the same units used for the pipe OD.*

If the pipe wall thickness is not available, look up the value in a table of standard pipe size data (such as the GE brochure *Sound Speeds and Pipe Size Data*, 914-004), or use the Model DF868's on-line *Help Menu* (see the *Programming Manual* for details).

For wetted transducers, skip to step 7.

2.6.5 Lining

6. Press [F1] if the pipe does not have a *Lining*, or [F2] if it does have a lining. If you select YES, complete the steps below.

- a. Use the [F1]-[F4] and [∅] keys to select the *Lining Material*. Options include Tar, Pyrex, Asbestos, Mortar, Rubber, PTFE and Other. If you choose "Other," the DF868 then asks you to enter the lining sound speed. If you do not know the lining sound speed, *Sound Speeds and Pipe Size Data* (914-004) lists some standard materials and their corresponding sound speeds.
- b. Enter the known *Lining Thickness*, in the same units used for the pipe OD, and press [ENT]. Then proceed to step 9.

2.6.6 Path and Axial Length

7. Enter the *Path Length* of the ultrasonic signal. Press [F1] or [F2] to select the desired units, and press [ENT].

Note: *The factory has calculated both the transducer signal path length (P) and the transducer signal axial length (L), based on the exact transducer configuration used for the application. These values are engraved on the flowcell and/or are included in the documentation supplied with the meter. See Appendix D for an explanation as to how these values are calculated.*

8. The next prompt varies, depending on whether you selected Transit-Time or TransFlection in the ACTIV menu.

- If you selected Transit-Time, the DF868 asks for the *Axial Length*. Enter the supplied value. Press [F1] or [F2] to select the desired units, and press [ENT].
- If you have selected TransFlection, enter the number of degrees for the *Transducer Angle*, and press [ENT]. Skip to step 10.

2.6.7 Tracking Windows

Note: *This step only appears if you have selected Transit-Time.*

9. Press [F1] if you do not want *Tracking Windows*, or [F2] if you want to enable the windows. (Tracking windows are used to detect the receive signal when you are unsure of the fluid soundspeed.)

2.6.8 Fluid Type

10. Use the [F1]-[F4] and [Ø] keys to select the *Fluid Type*. The selections for fluid type vary, depending on whether:

- the ENERGY OPTION is ON or OFF; and
- the TRACKING WINDOW is enabled or disabled.

Refer to Table 10 if ENERGY OPTION is OFF, or to Table 11 on page 27 if ENERGY OPTION is ON.

Note: *Some of the fluid types may require additional selections as shown in the following tables.*

Table 10: Fluid Types for ENERGY OFF

Tracking Windows =			
NO	Additional Selections	YES	Additional Selections
WATER	Select NORML or SEA and press [ENT]. If NORML is selected, enter the Water Temperature and press [ENT].	W100	No additional selections required.
OIL	Select LUBE or CRUDE and press [ENT].	W260	No additional selections required.
METH	No additional selections required.	OIL	No additional selections required.
ETH	Enter the Fluid Soundspeed and press [ENT].	OTHER	Enter the Minimum Soundspeed and press [ENT]. Then enter the Maximum Soundspeed and press [ENT]
LN2	No additional selections required.		
FREON	No additional selections required.		
OTHER	Enter the Fluid Soundspeed and press [ENT].		

Table 11: Fluid Types for ENERGY ON

Tracking Windows =			
NO	Additional Selections	YES	Additional Selections
WATER	Enter the Water Temperature and press [ENT].	W260	No additional selections required.
MIXED	Enter the Fluid Soundspeed and press [ENT]. Then enter the Percentage of Water and press [ENT].	MIXED	Enter the Percentage of Water and press [ENT].
OTHER	Enter the Fluid Soundspeed and press [ENT].	OTHER	Enter the Minimum Soundspeed and press [ENT]. Then enter the Maximum Soundspeed and press [ENT].

2.6.9 Reynolds Correction

11. Press [F1] to turn *Reynolds Correction* off, or [F2] to turn it on.

Note: *Reynolds Correction is a number based on the Kinematic Viscosity and flow rate of the fluid. It should be enabled for most applications.*

12. When you enable the Reynolds Correction Factor, you must also enter the *Kinematic Viscosity* of your fluid, as listed in *Sound Speeds and Pipe Size Data*. Use the numeric keys to enter a value, and press [ENT].

2.6.10 Calibration Factor

13. Enter a value for the flow *Calibration Factor* and press [ENT]. The default value is 1.00, but values between 0.50 and 2.00 may be entered.

14. The menu now varies, depending on whether you have activated the TransFlection or Transit-Time mode.

- If you activated the TransFlection mode, the program asks for the *Depth of Reflector*. This setting determines where in the pipe the DF868 looks for the reflected signal. The default value is 50%. Use the numeric keys to enter a value, and press [ENT].

Note: *GE recommends activating the Reynolds Correction Factor when the Depth of Reflector is set at 50%. You can disable the Reynolds Correction Factor when the Depth of Reflector is set at any other value.*

- If you activated the Transit-Time mode, two steps appear.
 - a. Use the [F1]-[F4] keys to select the desired *Number of Traverses*, the number of times the ultrasonic signal traverses the pipe, from 1 to 5.
 - b. The *Transducer Spacing* prompt displays the spacing of the transducers, as calculated from the information you have entered. Record this number and use it to properly space transducers.

Note: *If necessary, you can overwrite the spacing shown (using the numeric keys) to match the actual physical spacing of the transducers. The factory does not recommend overwriting the spacing. If you must, do not change the spacing by more than $\pm 10\%$ from the value shown.*

You have completed entering pipe parameters for clamp-on transducers. Press [ENT] to return to the start of the PIPE submenu, and [EXIT] to leave the submenu.

Table 12 lists the numeric parameters in the PIPE submenu, with their high and low limits.

Table 12: Low and High Limits for PIPE Parameters

Parameter	Low Limit	High Limit
Wedge Angle	25°	90°
Pipe OD	0.12 in.	300 in.
Pipe Wall	0 in.	4.0 in.
Lining Thickness	0 in.	4.0 in.
Kinematic Viscosity	0.1	10,000 (E-6 ft ² /s)
Path Length	0.12 in.	480 in.
Axial Length	0.12 in.	480 in.

2.7 Exiting the User Program

After the calibration factor entry has been made, the meter will exit the PIPE submenu and return to the initial *User Program* screen.

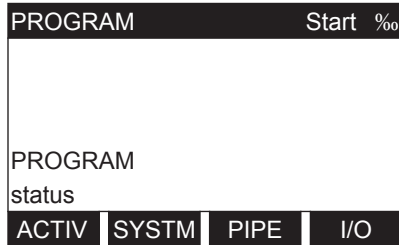

To leave the *User Program* and begin taking measurements, press [EXIT].

At the conclusion of the initial setup programming sequence, the following screen appears:

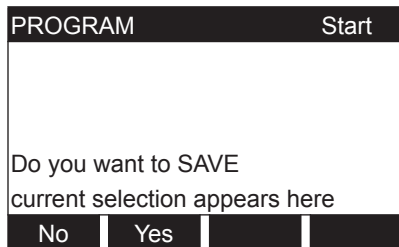

At the *User Program* screen shown, press [F1] to return to measurement mode without saving the file or press [F2] to enter the SAVE submenu.

Note: *If you press [NO], the DF868 still retains the newly programmed information. See the Programming Manual for instructions on using the SAVE submenu.*

Proceed to Chapter 3, *Operation*, for instructions on taking measurements or refer to the *Programming Manual* for instructions on programming the Model DF868's advanced features.

[no content intended for this page]

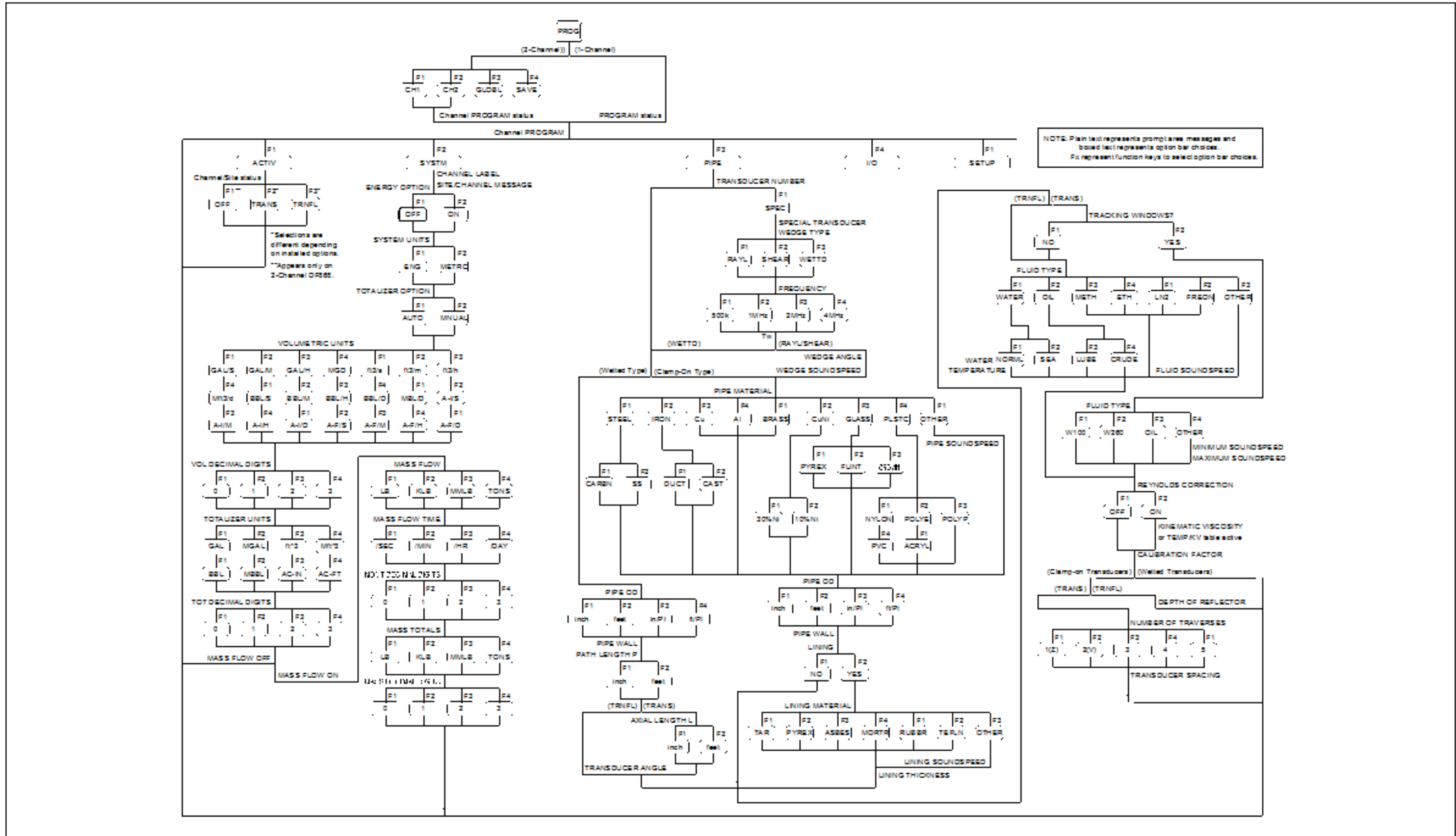

Figure 11: Model DF868 Initial Setup Menu Map with Energy Option Turned OFF

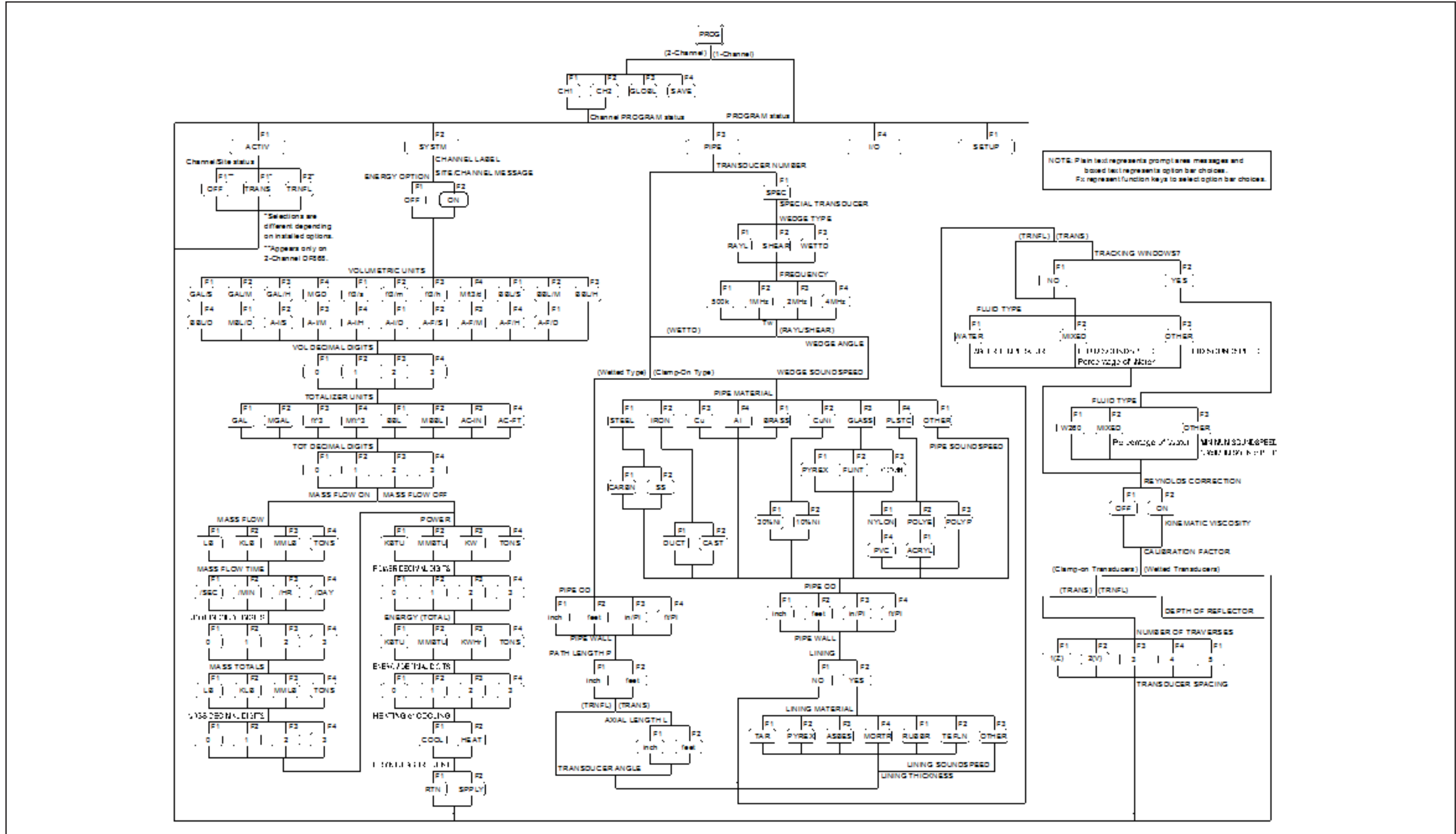

Figure 12: Model DF868 Initial Setup Menu Map with Energy Option Turned ON

Chapter 3. Operation

3.1 Introduction

See Chapter 1, *Installation*, and Chapter 2, *Initial Setup*, to prepare the system for operation. When the meter is ready to take measurements, proceed with this chapter. The following specific topics are discussed:

- Powering Up
- Using the Display
- Taking Measurements

Note: *All inputs and outputs of the Model DF868 are calibrated at the factory, prior to shipment. If it becomes necessary to recalibrate any of the inputs and/or outputs, see Chapter 1, Calibration, of the Service Manual.*

WARNING! To ensure the safe operation of the Model DF868, it must be installed and operated as described in this manual. In addition, be sure to follow all applicable local safety codes and regulations for the installation of electrical equipment.

3.2 Powering Up

Because the Model DF868 does not have an ON/OFF switch, it will power up as soon as the connected power source is energized.

Note: *For compliance with the European Union's Low Voltage Directive (73/23/EEC), this unit requires an external power disconnect device such as a switch or circuit breaker. The disconnect device must be marked as such, clearly visible, directly accessible, and located within 1.8 m (6 ft) of the Model DF868.*

Immediately upon power up, the Model DF868 displays the GE logo and the software version (2AA) in the left pane of the display window. The Model DF868 performs a series of internal checks and display the results in the right pane of the display window.

Note: *If the Model DF868 fails any of the internal checks, try disconnecting the power and then re-powering the unit. If the Model DF868 continues to fail any of the internal checks, contact the factory for assistance.*

After successfully performing the internal checks, the Model DF868 begins taking measurements. The power up display is replaced by a measurement mode display similar to that shown in Figure 13.

Note: *As a minimum, the system and pipe parameters (for each installed channel of a 2-channel meter) must be entered before the DF868 can display valid data. Refer to Chapter 2, Initial Setup, for specific instructions.*

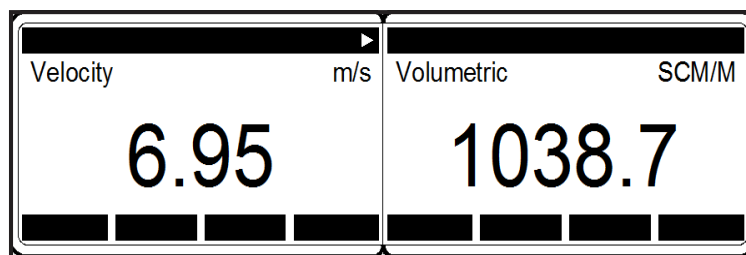

Figure 13: A Typical Measurement Display

Proceed to the next section for a description of the components of the Model DF868 display screen.

3.3 Using the Display

The Model DF868 display is divided into a left pane and a right pane. The two screen panes can be set independently to display any of the available measurement or diagnostic parameters. The components of a typical measurement mode screen are shown in Figure 14.

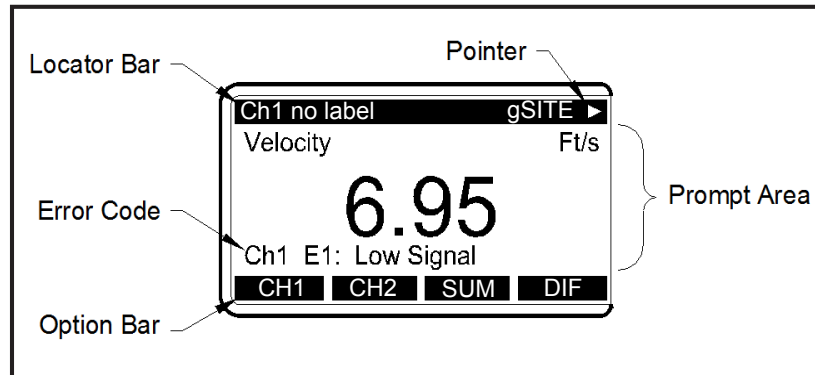

Figure 14: Display Screen Components

Both panes of the display screen are continuously updated, but only one pane at a time may be programmed or changed. To select a pane, press the corresponding side of the [SCREEN] key on the keypad. The currently selected screen pane will have function names in the option bar, while the other screen pane will have a blank option bar. See the *Programming Manual* for detailed instructions on using the keypad.

As shown in Figure 14, each pane of the display screen is divided into the following three general areas:

- the locator bar
- the prompt area
- the option bar.

The upper portion of the screen pane is called the *locator bar*. While the meter is taking measurements, the locator bar displays the name of the currently selected site file. In addition, the locator bar identifies the task that is currently being performed and the status of that task. For example, pressing the [PROG] key on the keypad will cause the locator bar to display “PROGRAM” and “Start” to indicate that the meter is ready to be programmed from the start of the *User Program*.

At various times, one or more of the following four symbols may be displayed on the far right of the locator bar:

- %: This symbol, which is called the *pointer*, indicates that additional option bar entries are available. These options can be accessed by using the [◆] and [∅] keys.
- *: A flashing asterisk indicates that the Model DF868 is currently logging information. See the *Programming Manual* for instructions on creating a log file.
- S or S_L: This symbol indicates the status of the red [SHIFT] key. “S” indicates that the [SHIFT] key is activated for the next keystroke only, while “S_L” indicates that the [SHIFT] key is locked. See the next section for instructions on using the keypad.
- T: This symbol indicates that the Model DF868 is currently totalizing data.

3.3 Using the Display (cont.)

The middle portion of the screen pane is the *prompt area*. This area displays data, graphs, and logs in measurement mode and menu prompts in programming mode. In addition, error code messages, which are described in the *Service Manual*, are displayed in the prompt area.

The lower portion of the screen pane is called the *option bar*. The option bar displays the functions assigned to the four keys immediately below the display screen ([F1]-[F4] for the left pane and [F5]-[F8] for the right pane). Press a function key to select the function listed in the option bar immediately above it. If more than four functions are available, a pointer (▶) appears on the far right of the locator bar. Press the [◆] or [∅] keys to display the additional functions on the option bar.

For information about other symbols and text that may appear on the display screen, refer to the *Service Manual*.

3.4 Taking Measurements

The Model DF868 is capable of displaying several different variables in a variety of formats. However, this manual will only discuss the basic measurement displays in the default screen format. Refer to the *Programming Manual* for instructions on setting up alternate screen displays and see the *Service Manual* for a discussion of the diagnostic parameters listed under the DIAG option.

Note: *This section assumes that the left pane of the display screen is currently active. However, the same instructions apply equally to the right screen pane, when it is active. Just change the function keys from [F1]-[F4] to [F5]-[F8].*

For a 2-channel Model DF868, the following initial screen appears immediately upon completion of the internal checks. As an example, the display shows the measured velocity in ft/sec for Channel 1.

Ch1 Channel Label	gSITE	%
Ch1 Velocity Ft/s		
6.95		
(error codes appear here)		
CH1	CH2	DIF

To select a different channel display option, press [F1]-[F4] (or [∅] and [F1]). See Table 13 for a complete description of the available options.

Table 13: Channel Display Options

Option Bar Choice	Description
[F1] = CH1	Channel 1
[F2] = CH2	Channel 2
[F3] = SUM	(Channel 1) + (Channel 2)
[F4] = DIF	(Channel 1) - (Channel 2)
[∅] + [F1] = AVE	[(Channel 1) + (Channel 2)]/2

3.4 Taking Measurements (cont.)

The following screen appears after selection of the channel mode display option for a 2-channel Model DF868 or immediately after the internal checks for a 1-channel Model DF868.

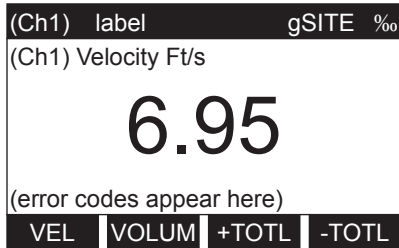

Use the [F1]-[F4], [◆] and [∅] keys to select the desired display parameter option. See Table 14 for a complete description of the available options.

Note: Ch1 (or Ch2), which is shown in parentheses above, appears only with a 2-Channel Model DF868.

Table 14: Measurement Parameter Options

Option Bar Choice	Description
[F1] = VEL	Flow Velocity
[F2] = VOLUM	Volumetric Flow
[F3] = +TOTL	Forward Totalized Volume Flow
[F4] = -TOTL	Reverse Totalized Volume Flow
[∅] + [F1] = TIME	Total Flow Measurement Time
[∅] + [F2] = MDOT*	Mass Flow
[∅] + [F3] = +MASS*	Forward Totalized Mass Flow
[∅] + [F4] = -MASS*	Reverse Totalized Mass Flow
[∅] + [∅] + [F1] = POWER**	Energy Flow Power
[∅] + [∅] + [F2] = +ENRG**	Forward Energy Flow
[∅] + [∅] + [F3] = -ENRG**	Reverse Energy Flow
[∅] + [∅] + [F4] = DIAG	Diagnostic
* Available only if Mass Flow is enabled	
** Available only if Energy Option is enabled	

In the SETUP submenu, the Advanced Features option offers a MASS (Mass Flow) option. The SYSTEM submenu offers an ENERGY OPTION. If you enable these options, the related options listed in Table 14 are available. However, if you do not enable these options, the six options indicated do not appear and the DIAG option will appear in the [F2] position on the second option bar screen.

By following the instructions in this section, the Model DF868 can be set up to display the desired channel option (for a 2-Channel meter) and the desired measurement parameter. To utilize the more advanced display capabilities of the Model DF868, refer to the *Programming Manual* and/or the *Service Manual* for the instrument.

3.4.1 Foundation Fieldbus Communications

Foundation Fieldbus provides a means of communicating with the flowmeter. The patent numbers which apply are 5,909,363 and 6,424,872.

This Foundation Fieldbus device supports two Analog Input (AI) blocks, which can be configured to supply the following measurements on the network (see Table 15 on page 37).

Table 15: Available Measurements Using Foundation Fieldbus

Channel 1	Units	Channel 2	Units	Average	Units
Ch1 Velocity	ft/s or m/s*	Ch2 Velocity	ft/s or m/s*	Avg Velocity	ft/s or m/s*
Ch1 Act Volumetric	VOL_U	Ch2 Act Volumetric	VOL_U	Avg Act Volumetric	VOL_U
Ch1 Std Volumetric	VOL_U	Ch2 Std Volumetric	VOL_U	Avg Std Volumetric	VOL_U
Ch1 Fwd Totals	TOT_U	Ch2 Fwd Totals	TOT_U	Avg Fwd Totals	TOT_U
Ch1 Rev Totals	TOT_U	Ch2 Rev Totals	TOT_U	Avg Rev Totals	TOT_U
Ch1 #Tot Digits**	none	Ch2 #Tot Digits**	none	Avg #Tot Digits**	none
Ch1 Mass Flow	MASS_U	Ch2 Mass Flow	MASS_U	Avg Mass Flow	MASS_U
Ch1 Fwd Mass Totals	MTOT_U	Ch2 Fwd Mass Totals	MTOT_U	Avg Fwd Mass Totals	MTOT_U
Ch1 Rev Mass Totals	MTOT_U	Ch2 Rev Mass Totals	MTOT_U	Avg Rev Mass Totals	MTOT_U
Ch1 #Mass Tot Digits	none	Ch2 #Mass Tot Digits	none	Avg #Mass Tot Digits	none
Ch1 Timer	sec	Ch2 Timer	sec	Avg Timer	sec
Ch1 Error Code	none	Ch2 Error Code	none	Avg Error Code	none
Ch1 SSUP	none	Ch2 SSUP	none	Avg SSUP	none
Ch1 SSDN	none	Ch2 SSDN	none	Avg SSDN	none
Ch1 Sound Speed	ft/s or m/s*	Ch2 Sound Speed	ft/s or m/s*	Avg Sound Speed	ft/s or m/s*
Ch1 Density***	see note	Ch2 Density***	see note		
Ch1 Temperature	Deg F or C*	Ch2 Temperature	Deg F or C*		
Ch1 Pressure	PRESS_U	Ch2 Pressure	PRESS_U		
<p>*Metric or English units are determined by the setup of the flowmeter.</p> <p>**Totalizer digits are available for informational purposes only. Respective totals are automatically scaled by the Tot Digits value selected in the flowmeter setup.</p> <p>***If the meter is outputting Mole Weight, the unit is "mw", otherwise it is the programmed pressure unit.</p> <p>VOL_U, TOT_U, MASS_U, MTOT_U and PRESS_U are determined by the units chosen for these measurements in the flowmeter setup. See the instrument User's Manual for the setup of these parameters.</p>					

[no content intended for this page]

Chapter 4. Specifications

4.1 General Specifications

The general specifications for the Model DF868 flowmeter are divided into the following categories:

4.1.1 Hardware Configuration

4.1.1a Package Options:

Epoxy-coated aluminum (standard), Stainless steel, Fiberglass, Explosion-proof

4.1.1b Physical:

Size: 14.24 × 11.4 × 5.12 in. (36.2 × 29 × 13 cm)

Weight: 11 lb (5 kg)

4.1.2 Environmental

4.1.2a Operating Temperature:

−4° to 131°F (−20° to 55°C)

4.1.2b Storage Temperature:

−67° to 167°F (−55° to 75°C)

4.1.3 Flow Accuracy (Velocity)

±0.5% of reading achievable with process calibration

4.1.3a Typical Clamp-On Flow Accuracy (Velocity)

Pipe Diameter (ID) > 6 in. (150 mm): ±1% to 2% of reading

Pipe Diameter (ID) ≤ 6 in. (150 mm): ±2 to 5% of reading

4.1.3b Typical Wetted Flow Accuracy:

±1% of reading

Note: Accuracy depends on pipe size, installation and whether measurement is one-path or two-path.

4.1.4 Range

4.1.4a *Transit-Time Mode:*

–40 to 40 ft/s (–12.2 to 12.2 m/s)

4.1.4b *TransFlection Mode:*

–1 to –30 ft/s (–0.3 to –9.1 m/s)

1 to 30 ft/s (0.3 to 9.1 m/s)

±1 to 15 ft/s (0.3 to 4.6 m/s)

4.1.5 Rangeability

4.1.5a *Transit-Time Mode:*

400:1

4.1.5b *TransFlection Mode:*

30 to 1

4.1.6 Repeatability

4.1.6a *Transit-Time Mode:*

Wetted Transducers: ±0.2% of full scale.

Clamp-on Transducers: ±0.2 to 0.5% of full scale.

4.1.6b *TransFlection Mode:*

Clamp-on Transducers: ±0.5% of full scale.

4.1.7 Energy Accuracy

The accuracy of the energy measurement is a combination of the accuracy of the associated flow and temperature measurements.

4.1.7a *Transit-Time Mode:*

1% of reading typical for calibrated systems.

4.1.7b *TransFlection Mode:*

2% of reading typical for calibrated systems.

4.1.8 Fluid Types

4.1.8a *Transit-Time Mode:*

Acoustically conductive fluids, including most clean liquids and many with entrained solids or gas bubbles. Maximum void fraction depends on transducer interrogation carrier frequency, path length and pipe configuration.

4.1.8b *TransFlection Mode:*

Multiphase fluids, including raw sewage, sludge, slurries, tar sands, acoustically attenuating liquids and other demanding applications.

4.2 Electrical Specifications

The electrical specifications for the Model DF868 flowmeter are divided into the following categories:

4.2.1 Power Supply

4.2.1a *Standard:*

100 to 130 VAC, 50/60 Hz

200 to 265 VAC, 50/60 Hz

4.2.1b *Optional:*

12 to 28 VDC, $\pm 5\%$

4.2.2 Power Usage

20 W maximum

4.2.3 Operating Modes

4.2.3a *Flow Measurement:*

Transit-Time for clamp-on or wetted transducers.

TransFlection for clamp-on transducers.

4.2.3b *Energy Measurement:*

To calculate energy flow rate, use Analog Input Board for transmitters. Use RTD Input board for direct RTDs.

4.2.4 European Compliance

This unit complies with EMC Directive 2004/108/EC and 2006/95/EC Low Voltage Directive (Installation Category II, Pollution Degree 2).

4.2.5 Hazardous (Classified) Location Compliance

4.2.5a CENELEC:

ISSeP Ex 96D1031261, EEx d IIC T6 when housed GUB 6 enclosure.

4.2.5b NEC:

Factory Mutual Research Corporation, J.K. 3Z9A1.AX, Class I, Division 2, Group A, B, C, D; Class II, division 2, Group F, G; Class III, Division 2, TYPE 4X, Tamb 50° C T4

4.2.5c CEC:

Canadian Standards Association, LR44204, Class I, Division 2, Group A, B, C, D; Class II, division 2, Group F, G; Class III, Division 2, TYPE 4X, Tamb 50° C T4

Note: Refer to Certificate of Compliance for details.

4.2.6 Input/Output Specifications

4.2.6a Keypad:

39-key membrane keypad with tactile feedback

4.2.6b Display:

Both single- and dual-channel models have two independent software-configurable 64 x 128-pixel LCD graphic displays

4.2.6c Digital Interfaces:

Standard: RS232

Optional: RS485 (multiuser)

Modbus[®] RTU

Modbus TCP

OPC server

Ethernet

4.2.6d Analog Input Options:

Select up to 3 boards of one of the following types:

Transmitter Input Board with two isolated 0/4–20 mA inputs and 24-V loop power.

RTD Input Board with two isolated 3-wire RTD inputs; Span –148° to 662°F (–100° to 350°C).

4.2.6e Analog Output Options:

All meters come with two isolated 0/4–20 mA current outputs (550 Ω maximum load).

Optional selection of up to 3 additional output boards, each with four isolated 0/4–20 mA outputs (1,000 Ω max. load).

4.2.6f Totalizer/Frequency Output Options:

Select up to 3 Totalizer/Frequency Output Boards, each with four outputs per board, 10 kHz max.

All boards allow software-selectable functioning in two modes:

Totalizer Mode: one pulse per defined unit of parameter (e.g., 1 pulse/gal).

Frequency Mode: pulse frequency proportional to magnitude of parameter (e.g., 10 Hz = 1 gpm).

4.2.6g Alarm Options:

Select up to 2 boards of one of the following types:

Basic Relay Board with three general purpose Form-C relays.

Hermetic Relay Board with three hermetically sealed Form-C relays.

Maximum Relay Ratings:

120 VAC AC Voltage, 28 VDC DV Voltage, 5A AC/DC Current,

60 VA AC Power, 30 W DC Power (General Purpose) or

56 W DC Power (Hermetically Sealed)

Note: *A maximum of six input/output option boards may be installed.*

4.3 Operational Specifications

The operational specifications for the Model DF868 flowmeter are divided into the following categories:

4.3.1 Site Parameter Programming

Menu-driven operator interface using keypad and “soft” function keys. Storage for 10 sites.

4.3.2 Data Logging

Keypad-programmable for setting up log units, update interval, start and stop times. Memory capacity for more than 43,000 flow data points in a linear or circular log.

4.3.3 Display Functions

Liquid crystal graphic display shows flow in numeric or graphic format. Also displays logged data and diagnostics.

4.3.4 Printer Signal Output

Supports wide variety of thermal and impact printers. Output data in numeric or graphic (“strip chart”) format.

4.4 Transducer Specifications

The transducer specifications for the Model DF868 flowmeter are divided into the following categories:

4.4.1 Wetted Ultrasonic Flow Transducers

4.4.1a Temperature Range

Standard: -40° to 212°F (-40° to 100°C)

Optional: -310° to 1112°F (-190° to 600°C)

4.4.1b Pressure Range

Standard: 0 to 3,000 psig (0.1013 to 20 MPa)

Optional: Higher pressures upon request.

4.4.1c Materials

Standard: 316 stainless steel

Optional (for isolating Pan-Adapta Plugs): Titanium, Hastelloy[®], PVC, PVDF and others.

4.4.1d Process Connections

Standard: 1" NPTM or 3/8" NTPM

Optional: RF flanged, socket weld, fuse bond and others.

4.4.1e Mounting

Spoolpiece, hot tap, cold tap.

4.4.1f Area Classifications

Standard: General-purpose

Optional:

Explosion proof: Class I, Div. 1, Groups C & D; Class II, Groups E, F and G; Class III

Flameproof:  II 2 G EEx d IIC T6

Weatherproof: Type 4/IP65.

Submersible.

4.4.2 Clamp-On Ultrasonic Flow Transducers

4.4.2a Temperature Range

Standard: -40° to 300°F (-40° to 150°C)

Optional: -310° to 572°F (-190° to 300°C)

4.4.2b Mounting

Stainless steel chain or strap, welded or magnetic clamping fixtures

4.4.2c Area Classifications

Standard: General-purpose

Optional:

Explosion proof: Class I, Div. 1, Groups B, C & D; Class II, Groups E, F and G; Class III

Flameproof: Ex II 2 G EEx md IIC T6-T3.

Weatherproof: Type 4/IP65.

Submersible.

Note: *Transducers, spoolpieces and clamping fixtures for special applications are available. Consult the factory for details.*

4.4.3 Temperature Transducers

Loop-powered, 3-wire platinum RTDs; clamp-on and wetted (thermowell) types are available. (RTD inputs must be PT100 only.)

4.4.3a Accuracy

0.15° , wetted RTDs (matched pairs).

4.4.3b Range

-4 to 500°F (-20° to 260°C).

Note: *Not all extremes of parameters can be achieved simultaneously.*

4.5 Pipe Size & Materials

4.5.1 Wetted Transducers

4.5.1a Materials

All metals and most plastics. (Consult the factory for concrete, glass and cement.)

4.5.1b Pipe Sizes

Transit-Time Mode:

(ID) 1 to 200 in. (25.4 mm to 5 m) and larger.

4.5.2 Clamp-On Transducers

4.5.2a Materials

All metals and most plastics. (Consult the factory for concrete, composite materials and highly corroded or lined pipes.)

[no content intended for this page]

4.5.2b Pipe Sizes

Transit-Time Mode:

Outside diameter (OD) 0.5 to 300 in. (12.7 mm to 7.6 m) and larger.

TransFlection Mode:

Outside diameter (OD) 2 to 200 in. (5 cm to 5 m) and larger.

Pipe Wall Thickness

Up to 3 in. (76.2 mm)

4.6 PC Interface Software

PanaView™ software option links the DF868 to a PC. Software package includes CD and manual.

Appendix A. CE Mark Compliance

A.1 Introduction

For CE Mark compliance, the Model DF868 flowmeter must be wired in accordance with the instructions in this appendix.

IMPORTANT: *CE Mark compliance is required only for units intended for use in EEC countries.*

A.2 Wiring

The Model DF868 must be wired with the recommended cable, and all connections must be properly shielded and grounded. Refer to Table 16 for the specific requirements.

Table 16: Wiring Modifications

Connection	Cable Type	Termination Modification
Transducer	RG62 a/u	Add a metallic cable clamp from the braid to the chassis ground.
	Armored RG62 a/u or conduit	None - grounded using a cable gland.
Input/Output	22 AWG shielded (e.g. Baystate #78-1197)	Terminate the shield to the chassis ground.
	Armored conduit	None - grounded using a cable gland.
Power	14 AWG, 3 conductor, shielded (e.g. Belden #19364)	An external ground to the chassis is required.
	Armored Conduit	None - grounded using a cable gland.
Shielding	For CE compliance, power and I/O cables must be shielded. Cables to be terminated within a cable gland at the DF868. Shielded cable is not required when installations include metal conduit.	

A.3 External Grounding

For CE Mark compliance, the electronics enclosure and the transducer fixture must each have an external ground wire attached.

Note: *If the Model DF868 is wired as described in this appendix, the unit will comply with the EMC Directive 89/336/EEC.*

[no content intended for this page]

Appendix B. Data Records

B.1 Option Cards Installed

Whenever an option card is installed in one of the Model DF868's expansion slots, record the type of card and any additional setup information in the appropriate row of Table 17.

Table 17: Option Cards Installed

Slot #	Type of Option Card	Additional Setup Information
0	Analog Outputs (A, B)	
1		
2		
3		
4		
5		
6		

B.2 Initial Setup Data

After the Model DF868 flowmeter has been installed, some initial setup data must be entered via the *User Program*, prior to operation. Record that information in Table 18.

Table 18: Initial Setup Data

General Information						
Model #				Serial #		
Software Vers.				Setup Date		
GLOBL-SYSTM						
System Units	English	Metric		Vol. Dec. Digits		
Totalizer Option	Auto	Manual		Totalizer Units		
Vol. Units				Tot. Dec. Dig.		
GLOBL-I/O-ERROR						
Error Handling				2-Path Error	No	Yes
GLOBL-COMM						
Meter Address				Baud Rate		
CHx-ACTIVE						
Channel 1			Channel 2 (if applicable)			
Channel Status	Off ¹	Trans	Tranfl	Channel Status	Off ¹	Trans Tranfl
CHx-SYSTM						
Channel 1			Channel 2 (if applicable)			
Channel Label			Channel Label			
Chan. Message ²			Chan. Message ²			
Energy Option	On	Off	Energy Option	On	Off	
Vol. Units			Vol. Units			
Vol. Dec. Digits			Vol. Dec. Digits			
Totalizer Units			Totalizer Units			
Tot. Dec. Dig.			Tot. Dec. Dig.			
Mass Flow			Mass Flow			
Mass Flow Time			Mass Flow Time			
MDOT Dec. Dig.			MDOT Dec. Dig.			
Mass Totals			Mass Totals			
Mass Dec. Digits			Mass Dec. Digits			
Power			Power			
Power Dec. Dig.			Power Dec. Dig.			
Energy (Total)			Energy (Total)			
Energy Dec. Dig.			Energy Dec. Dig.			
Heat. or Cool.			Heat. or Cool.			
Flow Meas.			Flow Meas.			
¹ not available for 1-Channel meter, ² "Site Message" for 1-Channel meter						

Table 18: Initial Setup Data (cont.)

CHx-I/O							
Zero Cutoff				Temp. Input	Fixed ()	Live	
Pipe/Transducer Parameters - PIPE							
Channel 1				Channel 2 (if applicable)			
Trans. Type	STD	SPEC		Trans. Type	STD	SPEC	
Transducer #				Transducer #			
Special Transducers				Special Transducers			
Wedge Type	Rayl	Shear	Wettd	Wedge Type	Rayl	Shear	Wettd
Frequency Hz				Frequency Hz			
Trans. Tw				Trans. Tw			
Wedge Angle				Wedge Angle			
Wedge Sndspd				Wedge Sndspd			
Pipe Material				Pipe Material			
All Clamp-On and Wetted Transducers				All Clamp-On and Wetted Transducers			
Pipe O.D.				Pipe O.D.			
Pipe Wall				Pipe Wall			
Path Length (P)				Path Length (P)			
Axial Length (L)				Axial Length (L)			
Trans. Angle				Trans. Angle			
Lining	Yes	No		Lining	Yes	No	
Lining Material				Lining Material			
Lining Sndspd				Lining Sndspd			
Lining Thickness				Lining Thickness			
Track. Window.	Yes	No		Track. Window.	Yes	No	
Fluid Type				Fluid Type			
Other/Sndspd				Other/Sndspd			
% of Water				% of Water			
Reynolds Corr.	Off	Active		Reynolds Corr.	Off	Active	
KV Input Sel.	Table	Static		KV Input Sel.	Table	Static	
Kin. Visc.				Kin. Visc.			
Cal. Factor				Cal. Factor			
# of Traverses				# of Traverses			
Trans. Spacing				Trans. Spacing			
Depth of Reflect.				Depth of Reflect.			
CHx-SETUP-AVRG							
Response Time							

Table 18: Initial Setup Data (cont.)

CHx-SETUP-ADVAN-KV/SS						
KV/SS Pairs				KV/SS Pairs		
#	Sig. Stren.	Kin. Visc.		#	Sig. Stren.	Kin. Visc.
1				1		
2				2		
3				3		
4				4		
5				5		
6				6		
7				7		
8				8		
9				9		
10				10		
11				11		
12				12		
13				13		
14				14		
15				15		
16				16		
17				17		
18				18		
19				19		
20				20		
CHx-SETUP-ADVAN-MULTIK						
Custom Type	CstV	CstR		Custom Type	CstV	CstR
K-Factor Table				K-Factor Table		
K-Factor #	Vel./Reyn.	K Factor		K-Factor #	Vel./Reyn.	K Factor
1				1		
2				2		
3				3		
4				4		
5				5		
6				6		
7				7		
8				8		
9				9		
10				10		
11				11		
12				12		

Table 18: Initial Setup Data (cont.)

CH_x-SETUP-ADVAN-MULTIK (cont.)						
K-Factor Table				K-Factor Table		
K-Factor #	Vel./Reyn.	K Factor		K-Factor #	Vel./Reyn.	K Factor
13				13		
14				14		
15				15		
16				16		
17				17		
18				18		
19				19		
20				20		
CH_x-SETUP-ADVAN-MASS						
Channel 1				Channel 2 (if applicable)		
Mass Flow	No	Yes		Mass Flow	No	Yes
Static Density				Static Density		
CH_x-SETUP-ADVAN-CODEL						
Code Length	Auto 1bit 2bit	4bit 11bit		Code Length	Auto 1bit 2bit	4bit 11bit
CH_x-SETUP-ADVAN-ActTw						
Active Tw	No	Yes		Active Tw	No	Yes
Minimum Tw				Minimum Tw		
Maximum Tw				Maximum Tw		

[no content intended for this page]

Appendix C. Optional Enclosures

C.1 Introduction

Upon request the Model DF868 flowmeter may be supplied in an enclosure other than the standard Type-4X enclosure described in Chapter 1, *Installation*, of this manual. Although the standard installation and wiring instructions still apply in general terms, some of the details may vary for different enclosure types. Refer to the appropriate sections of this appendix for the specific type of enclosure provided.

C.2 Rack Mount Enclosure

The Model DF868 flowmeter is available in a *rack mount* enclosure for installation in a standard 19" electronics rack. Refer to Figure 15 on page 57 for the dimensions of this unit. Simply slide the Model DF868 into the rack at the desired height and fasten the unit securely to the rack with four screws in the locations provided at the sides of the front panel.

After the unit has been physically mounted into the rack, proceed to the next section for instructions on wiring the meter.

C.3 Rack Mount Wiring

The rack mount Model DF868 requires exactly the same electrical connections as the standard version. However, the locations and type of connectors used for the various components are different. Refer to Figure 16 on page 58 and complete the following steps:

1. Wire the *power input* on the right side of the rear panel as follows:
 - a. Make sure a *fuse* (item #4) of the proper size and type is installed.
 - b. Connect the female end of the *line cord* provided to the power input receptacle (item #3).
 - c. Connect the *earth ground* screw terminal (item #2) to a ground point on the rack.
2. Wire the *transducers* as follows:
 - a. Connect the pair of cables supplied with the meter to the *Channel 1* upstream and downstream BNC transducer connectors on the left side of the rear panel.
 - b. For a 2-Channel meter, repeat the above step for the *Channel 2* transducer connectors (if the second channel is to be used).
 - c. Complete the transducer wiring in accordance with the instructions in Chapter 1, *Installation*, of this manual.

C.3 Rack Mount Wiring (cont.)

3. Wire the 0/4-20 mA *analog outputs* at the left side of the rear panel in accordance with the instructions in Chapter 1, *Installation*, of this manual.
4. Wire the *RS232 serial port* by completing the following steps:
 - a. Purchase or prepare a suitable serial cable. This cable should have a standard female DB9 connector, wired as shown in Figure 16 on page 58, for connection to the rear panel of the Model DF868. The other end should be as required for the external device.
 - b. Complete the serial port wiring in accordance with the instructions in Chapter 1, *Installation*, of this manual.
5. Wire any installed *option cards* using the same procedures described in Chapter 1, *Installation*, of this manual and the pin # assignments shown in Figure 16 on page 58.
6. Place the *power switch* (item #1) in the ON position.

The Model DF868 is now completely wired. Proceed to Chapter 2, *Initial Setup*, of this manual for further instructions.

C.4 Rack Mount Front Panel

The keypad and LCD display for the rack mount Model DF868 are located on the front panel. These items are identical in form and function to those used on the standard Type-4X enclosure, but the layout is somewhat different.

Refer to Figure 17 on page 59 for the front panel layout of the rack mount Model DF868 and follow the standard procedures detailed in the main body of this manual.

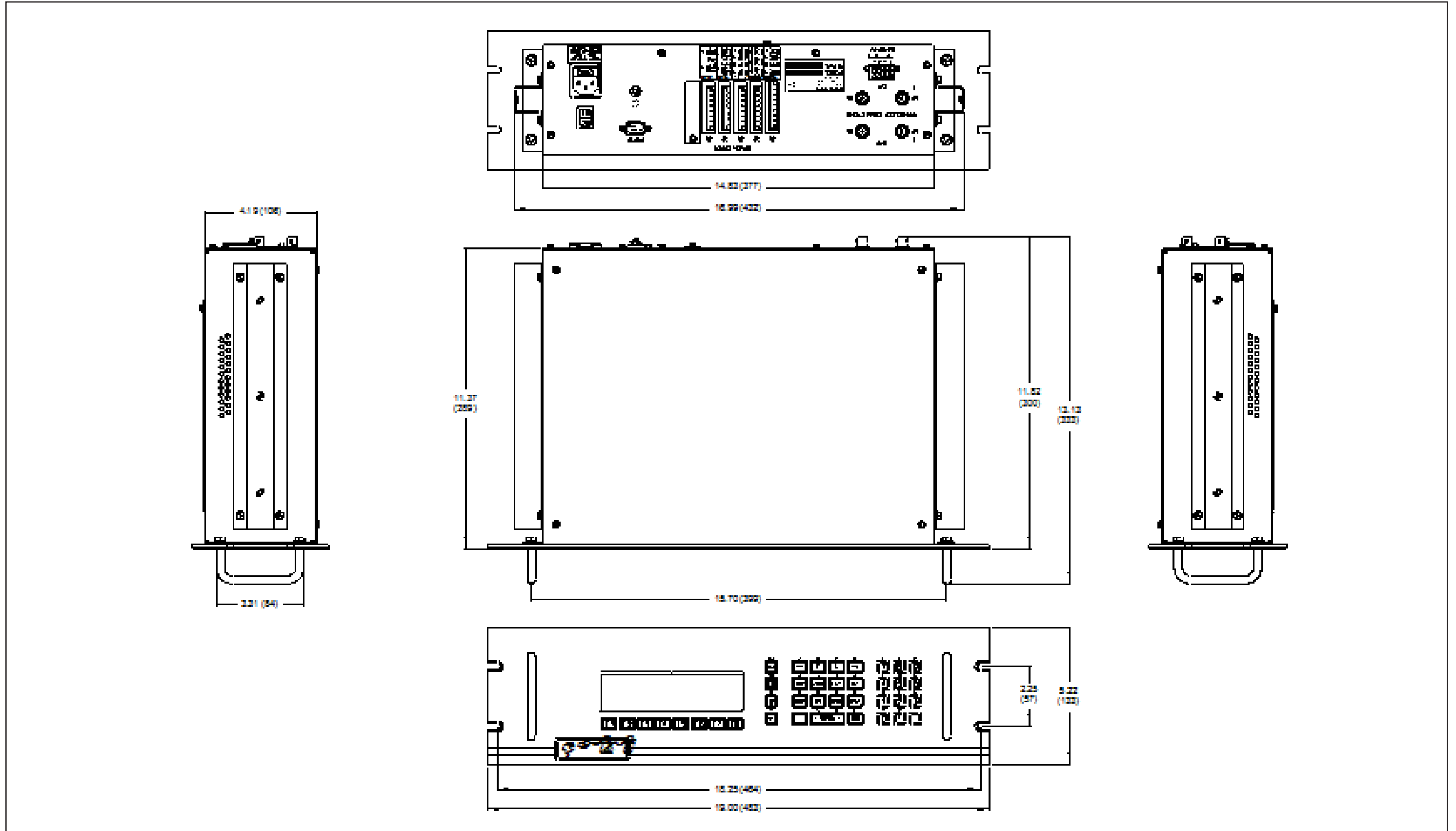

Figure 15: Model DF868 Rack Mount Enclosure (ref. dwg #712-1078)

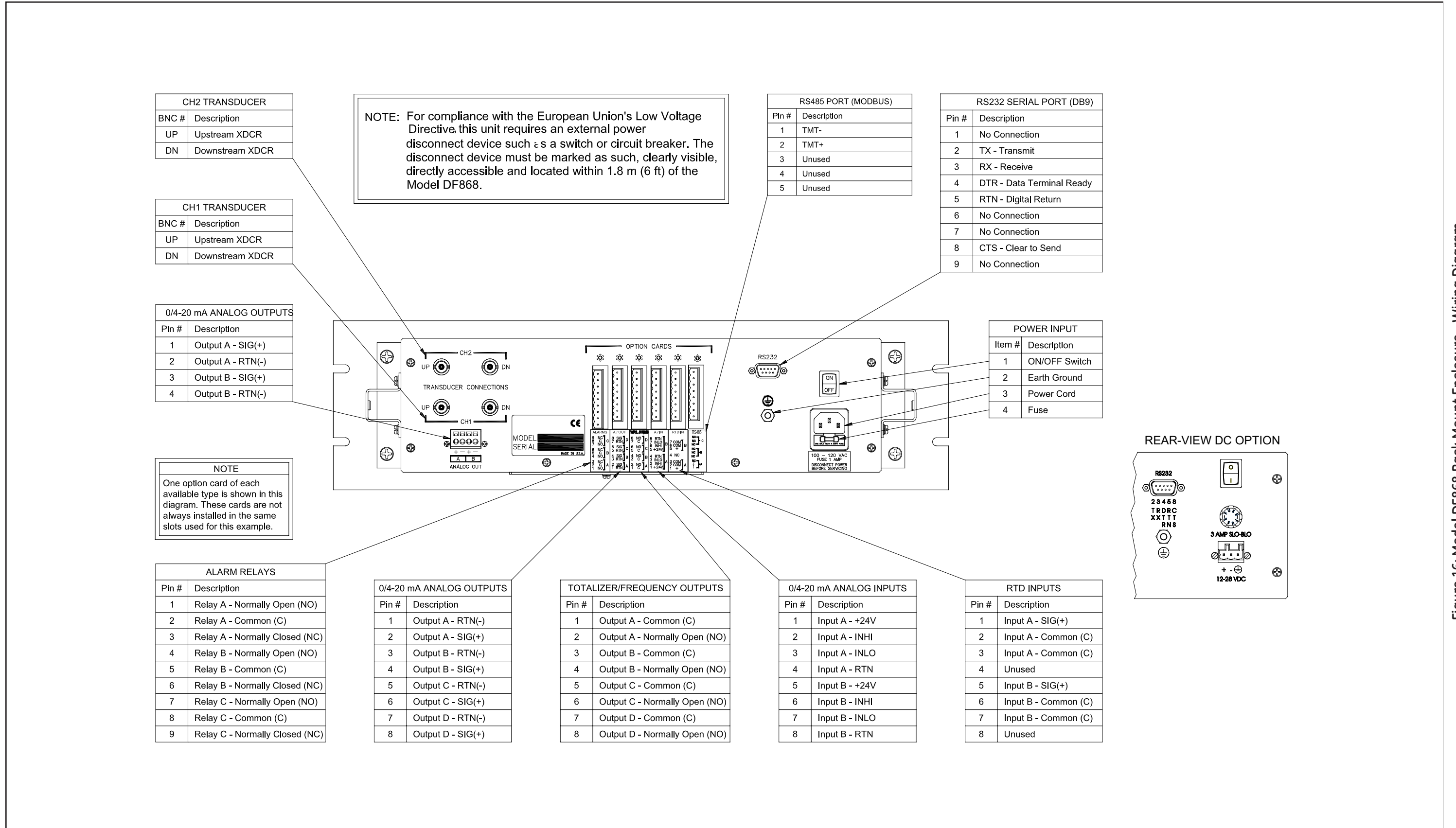

Figure 16: Model DF868 Rack Mount Enclosure - Wiring Diagram

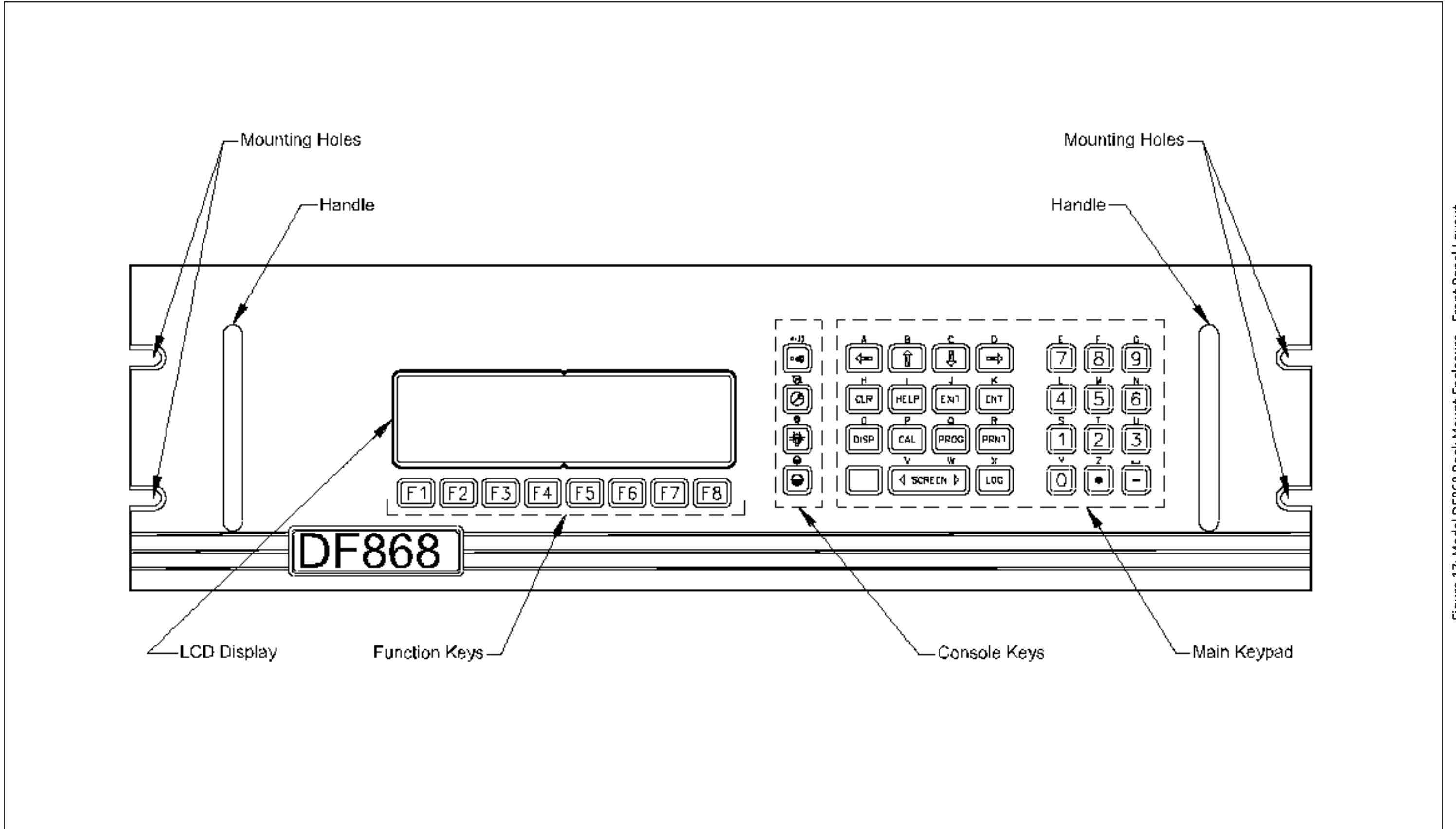

Figure 17: Model DF868 Rack Mount Enclosure - Front Panel Layout

Appendix D. Measuring P and L Dimensions

D.1 Measuring P and L

If you are using wetted transducers, the DF868 requires you to enter the path length (P) and the axial dimension (L). P is the transducer face-to-face distance, and L is the axial projection of P in the flow stream.

To determine L, physically measure the distance between the center of the transducer ports at the inside wall as shown in Figure 18, if possible. If not, consult the factory.

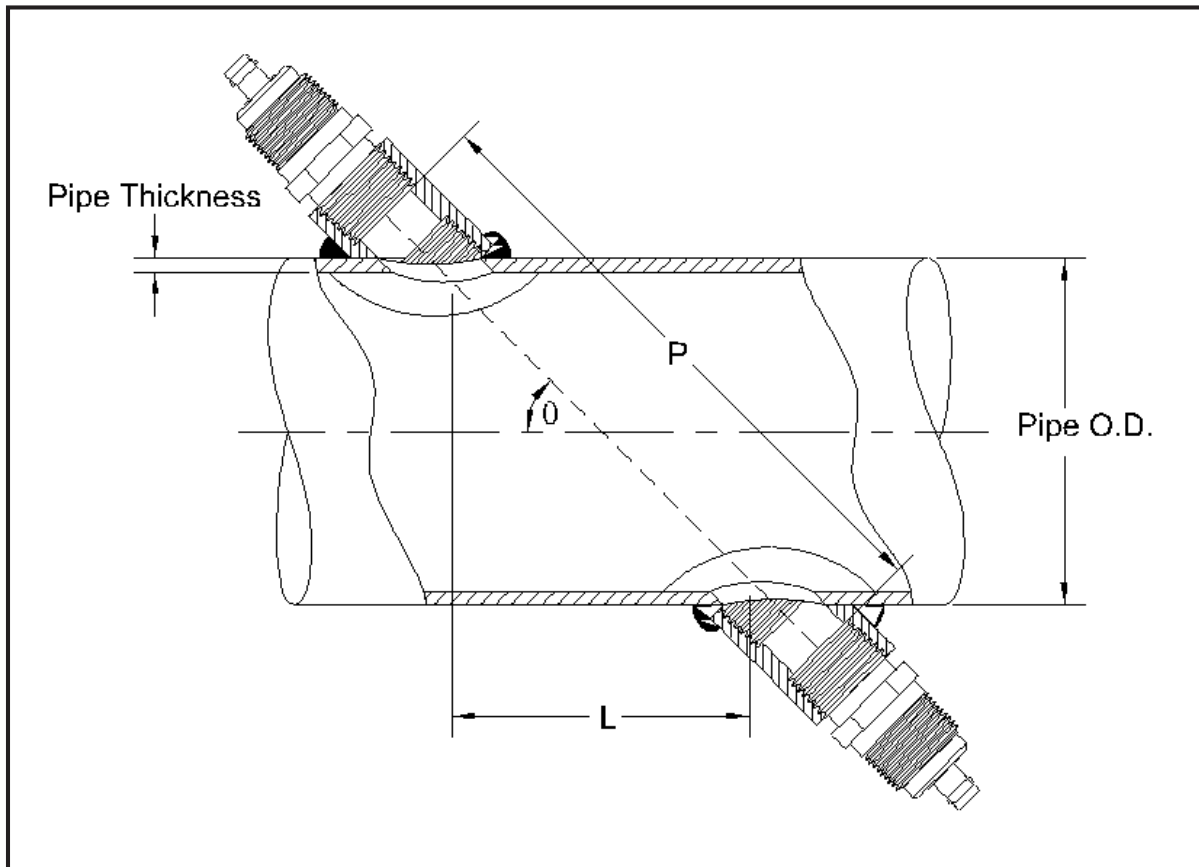

Figure 18: Top View of 180° Transducer Installation

To determine P, you need the following:

- the pipe inside diameter (ID)
- the wall thickness (WT)
- the installed pipe coupling length (CL)
- the transducers face depth (FD)
- the mounting angle (MA)

D.1 Measuring P and L (cont.)

Use Figure 19 to properly measure the coupling length. Typically, the transducer face is positioned just outside the inside diameter (ID) of the pipe, or slightly retracted inside the coupling.

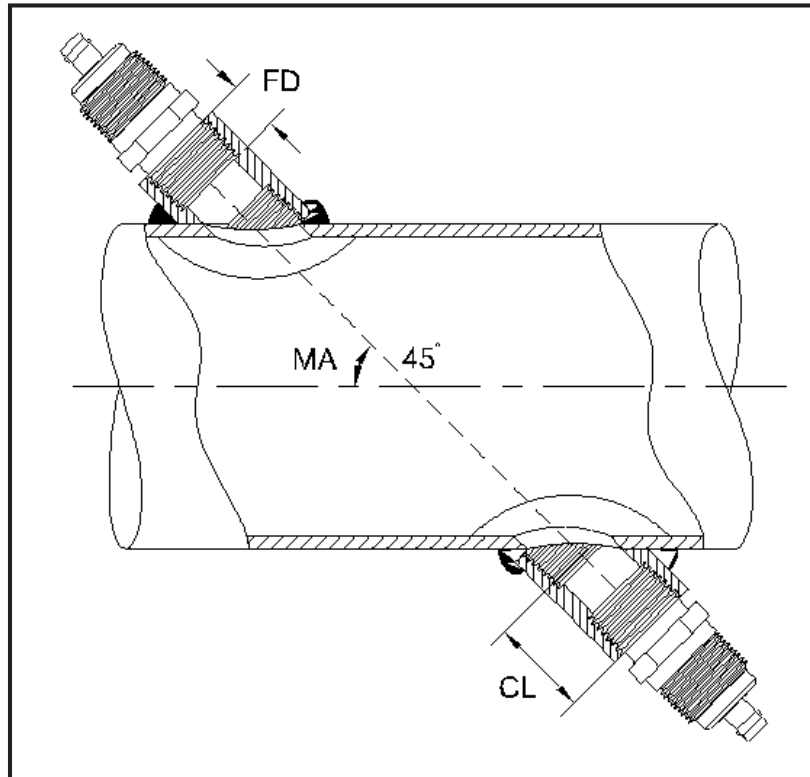

Figure 19: Determining the Pipe Coupling Length

Use the following formula to determine the P dimension:

$$[ID + 2(WT)]/(\cos MA) + 2(CL - FD) = P \text{ dimension}$$

For example, given the following:

- inside diameter (ID) = 48"
- wall thickness (WT) = 3/8"
- installed coupling length (CL) = 2.0"
- a transducer face depth (FD) = 1.75"
- mounting angle (MA) = 45°

The P dimension would be: $[48 + 2(3/8)]/(0.7071) + 2(2.0 - 1.75) = 69.4"$

A	D
Abbreviations, Volumetric Units 21	Dimensions
ACTIV Submenu 19	Bench Mount 16, 60
Alarms Option Card	Rack Mount 15, 57, 59
Connecting 11	Display
Fail-Safe Operation 11	Channel Mode Options 35
Relay Ratings 42	Components 34
Analog Inputs Option Card	Data 33
Connecting 12	Locator Bar 34
Pin Assignments 12	Locator Bar Symbols 34
Rating 12	Measurement Mode 33
Ratings 42	Option Bar 34
Analog Outputs (Slot 0)	Parameter Options 36
Connecting 7	Pointer 34
Analog Outputs Option Card	Prompt Area 34
Connecting 14	Selecting 34
	Using 34
B	E
Bench Mount	Electrical Connectors 5
Dimensions 16, 60	Electronics Console
Outline 16, 60	Description 2
	Mounting 4
C	Ethernet, Wiring 9
Cable	F
Serial Port 8	Fieldbus Network 10
Transducers 2, 3	Connections 10
CE Mark Compliance 1, 47	Flowcell
Connecting	Description 2
See Part Name	Installing 3
Connectors, Electrical 5	Foundation Fieldbus
	Available Measurements 37
	Function Keys 35
	I
	Information Paragraphs vii
	Initial Setup
	Data Table 50
	Minimum Required 17
	Input Voltage 5
	Internal Tests 33

L	P
Lightning Protector, Connecting	Parameter Options
Locator Bar	Password
LVD Shroud	Path Length, Programming
LVD Statement	PC Interface Software
	Pipe Materials
M	Pipe OD, Programming
Mass Flow Units	Pipe Sizes
Available Options.	PIPE Submenu
Setting.	Pipe Wall, Programming
Measurements	Pointer
Displaying.	Power
Parameter Options	Connecting
Taking.	Terminal Block
MODBUS Option Card, Wiring	Powering Up
MODBUS/TCP, Wiring	Display
	Internal Checks
O	Pressure Transmitter
Option Bar	Installing
Option Card	Location
Alarms	Prompt Area
Analog Inputs	
Analog Outputs	R
RTD Inputs	Rack Mount
Setup Information Table	Dimensions
Totalizer/Frequency Outputs.	Front Panel
Outline	Installation
Bench Mount.	Outline
Rack Mount.	Wiring.
	Return Policy
	RS232 Port
	See Serial Port
	RS485.
	RTD Inputs Option Card, Connecting
	RTD Temperature Transmitter

S

Safety

- Auxiliary Equipment vii
- General Issues vii
- Personal Equipment vii

SAVE Submenu 19

Screen, Selecting 34

Security Feature 18

Serial Port

- Cable 8
- Connecting 7
- Pin Assignments 7

Shroud

- LVD 5
- Plastic 5

Slot 0

- See Analog Outputs (Slot 0)

Specifications

- Electrical 41
- General 39
- Operational 43
- Pipe Materials 45
- Pipe Size 45
- Transducer 43

Symbols, Locator Bar 34

System Units 19

SYSTEM Submenu 19

T

Temperature Transmitter

- Installing 4
- Location 2
- RTD 4

Terminal Block

- Analog Outputs - I/O 7
- Power - TB1 5
- Serial Port - RS232 7
- Transducers - CH1/CH2 7

Totalizer/Frequency Option Card

- Connecting 13

T (cont.)

Transducers

- Axial Dimension 61
- Bias 90° Installation 61
- Cables 2, 3
- Installation Angle 61
- Location 2
- Path Length 61

Transmitter

- See Temperature or Pressure Transmitter

U

Unpacking 1

User Program

- ACTIV Submenu 19
- Entering 18
- Exiting 19
- Navigating 17
- PIPE Submenu 24
- SAVE Submenu 19
- SYSTEM Submenu 19

V

Voltage, Input 5

Volumetric Units

- Abbreviations 21
- Selecting 21
- Table of Options 21

W

Warranty 67

Wiring

- CE Mark Compliance 47
- Foundation Fieldbus 10
- Option Card See Card Name
- Terminal Block See Block Name

[no content intended for this page]

Warranty

Each instrument manufactured by GE Sensing is warranted to be free from defects in material and workmanship. Liability under this warranty is limited to restoring the instrument to normal operation or replacing the instrument, at the sole discretion of GE Sensing. Fuses and batteries are specifically excluded from any liability. This warranty is effective from the date of delivery to the original purchaser. If GE Sensing determines that the equipment was defective, the warranty period is:

- one year from delivery for electronic or mechanical failures
- one year from delivery for sensor shelf life

If GE Sensing determines that the equipment was damaged by misuse, improper installation, the use of unauthorized replacement parts, or operating conditions outside the guidelines specified by GE Sensing, the repairs are not covered under this warranty.

The warranties set forth herein are exclusive and are in lieu of all other warranties whether statutory, express or implied (including warranties or merchantability and fitness for a particular purpose, and warranties arising from course of dealing or usage or trade).

Return Policy

If a GE Sensing instrument malfunctions within the warranty period, the following procedure must be completed:

1. Notify GE Sensing, giving full details of the problem, and provide the model number and serial number of the instrument. If the nature of the problem indicates the need for factory service, GE Sensing will issue a RETURN AUTHORIZATION NUMBER (RAN), and shipping instructions for the return of the instrument to a service center will be provided.
2. If GE Sensing instructs you to send your instrument to a service center, it must be shipped prepaid to the authorized repair station indicated in the shipping instructions.
3. Upon receipt, GE Sensing will evaluate the instrument to determine the cause of the malfunction.

Then, one of the following courses of action will then be taken:

- If the damage is covered under the terms of the warranty, the instrument will be repaired at no cost to the owner and returned.
- If GE Sensing determines that the damage is not covered under the terms of the warranty, or if the warranty has expired, an estimate for the cost of the repairs at standard rates will be provided. Upon receipt of the owner's approval to proceed, the instrument will be repaired and returned.

[no content intended for this page]

We,

GE Sensing
1100 Technology Park Drive
Billerica, MA 01821
USA

declare under our sole responsibility that the

DigitalFlow™ DF8688 Liquid Ultrasonic Flowmeter
DigitalFlow™ GC868 Clamp-On Gas Ultrasonic Flowmeter
DigitalFlow™ GF868 Flare Gas Mass Ultrasonic Flowmeter
DigitalFlow™ GM868 General-Purpose Gas Ultrasonic Flowmeter
DigitalFlow™ GS868 Steam Mass Ultrasonic Flowmeter

to which this declaration relates, are in conformity with the following standards:

- EN 60079-0: 2009
- EN 60079-1: 2007
- EN60529: 1991 + A1: 2000
- II 2 G Ex d IIB+H2 T6 Gb Ta = 20°C to 60°C; IP66; FM12ATEX0040X
(FM Approvals Ltd, Windsor, Berkshire, UK - NoBo 1725)
- EN 61326-1: 2006, Class A, Table 2, Industrial Locations
- EN 61326-2-3: 2006
- EN 61010-1: 2012, Overvoltage Category II

following the provisions of the 2004/108/EC EMC, 2006/95/EC Low Voltage and 94/9/EC ATEX Directives.

The unit listed above and any ancillary equipment supplied with it do not bear CE marking for the Pressure Equipment Directive, as they are supplied in accordance with Article 3, Section 3 (sound engineering practices and codes of good workmanship) of the Pressure Equipment Directive 97/23/EC for DN<25.

Billerica - February 12, 2015

Issued



Mr. Gary Kozinski
Certification & Standards, Lead Engineer



Customer Support Centers

U.S.A.

The Boston Center
1100 Technology Park Drive
Billerica, MA 01821
U.S.A.
Tel: 800 833 9438 (toll-free)
978 437 1000
E-mail: sensing@ge.com

Ireland

Sensing House
Shannon Free Zone East
Shannon, County Clare
Ireland
Tel: +353 61 61470200
E-mail: gesensingsnnservices@ge.com

An ISO 9001:2008 Certified Company

www.gemeasurement.com/en/about-us/quality.html

www.gemeasurement.com

©2016 General Electric Company. All rights reserved.
Technical content subject to change without notice.