

GE Infrastructure
Sensing



DigitalFlow™ GC868

Panometrics Gas Clamp-On Ultrasonic Flowmeter

Service Manual (1 and 2-Channel)



GE Infrastructure
Sensing

DigitalFlow™ GC868

Panometrics Gas Clamp-On Ultrasonic Flowmeter



Service Manual (1 and 2-Channel)

910-226SD1

December 2004

DigitalFlow™ is a GE Panometrics product. GE Panometrics has joined other GE high-technology sensing businesses under a new name—GE Infrastructure Sensing.



Warranty

Each instrument manufactured by GE Infrastructure Sensing, Inc. is warranted to be free from defects in material and workmanship. Liability under this warranty is limited to restoring the instrument to normal operation or replacing the instrument, at the sole discretion of GE Infrastructure Sensing, Inc. Fuses and batteries are specifically excluded from any liability. This warranty is effective from the date of delivery to the original purchaser. If GE Infrastructure Sensing, Inc. determines that the equipment was defective, the warranty period is:

- one year for general electronic failures of the instrument
- one year for mechanical failures of the sensor

If GE Infrastructure Sensing, Inc. determines that the equipment was damaged by misuse, improper installation, the use of unauthorized replacement parts, or operating conditions outside the guidelines specified by GE Infrastructure Sensing, Inc., the repairs are not covered under this warranty.

The warranties set forth herein are exclusive and are in lieu of all other warranties whether statutory, express or implied (including warranties of merchantability and fitness for a particular purpose, and warranties arising from course of dealing or usage or trade).

Return Policy

If a GE Infrastructure Sensing, Inc. instrument malfunctions within the warranty period, the following procedure must be completed:

1. Notify GE Infrastructure Sensing, Inc., giving full details of the problem, and provide the model number and serial number of the instrument. If the nature of the problem indicates the need for factory service, GE Infrastructure Sensing, Inc. will issue a RETURN AUTHORIZATION number (RA), and shipping instructions for the return of the instrument to a service center will be provided.
2. If GE Infrastructure Sensing, Inc. instructs you to send your instrument to a service center, it must be shipped prepaid to the authorized repair station indicated in the shipping instructions.
3. Upon receipt, GE Infrastructure Sensing, Inc. will evaluate the instrument to determine the cause of the malfunction.

Then, one of the following courses of action will then be taken:

- If the damage is covered under the terms of the warranty, the instrument will be repaired at no cost to the owner and returned.
- If GE Infrastructure Sensing, Inc. determines that the damage is not covered under the terms of the warranty, or if the warranty has expired, an estimate for the cost of the repairs at standard rates will be provided. Upon receipt of the owner's approval to proceed, the instrument will be repaired and returned.

Table of Contents

Chapter 1: Calibration

Introduction	1-1
Menu Map	1-1
Calibrating the Analog Outputs	1-2
Accessing the Calibration Menu	1-3
Calibrating the Low End of the Output Range	1-3
Calibrating the High End of the Output Range	1-4
Testing the Analog Output Linearity	1-4
What's Next?	1-5
Calibrating the Analog Inputs	1-6
Accessing the Calibration Menu	1-7
aLOW Option = [F1]	1-8
aHIGH Option = [F2]	1-8
4 mA Option = [F3]	1-8
20 mA Option = [F4]	1-8
What's Next?	1-8
Calibrating the RTD Inputs	1-9
Accessing the Calibration Menu	1-9
Probe Option = [F1]	1-9
Numer Option = [F2]	1-10
What's Next?	1-10
Testing the Alarm Relays	1-11
Accessing the Calibration Menu	1-11
What's Next?	1-12
Testing the Totalizer/Frequency Outputs	1-13
Accessing the Calibration Menu	1-13
Entering Frequency	1-13
Entering Pulse Number	1-14
What's Next?	1-14

Table of Contents (cont.)

Chapter 2: Error Codes and Screen Messages

Introduction	2-1
E0: No Error	2-2
E1: Low Signal	2-2
E2: Sound Speed Error	2-2
E3: Velocity Range	2-2
E4: Signal Quality	2-3
E5: Amplitude Error	2-3
E6: Cycle Skip, Accel.	2-3
E7: Analog Out Error	2-3
E8: Temp In	2-3
E9: Press In	2-4
E10: Special Input	2-4
E11: Not Used	2-4
E12: Not Used	2-4
E13: Over Range	2-4
E14: Totals Overflow	2-4
E15: Equation Limit	2-4
E16: High Signal	2-5
Screen Messages	2-5

Chapter 3: Diagnostics

Introduction	3-1
Displaying Diagnostic Parameters	3-1
Diagnostic Record	3-4
Flowcell Problems	3-4
Gas Problems	3-4
Pipe Problems	3-5
Transducer Problems	3-6

Chapter 4: Parts Replacement

Introduction	4-1
Fuse Replacement	4-2
Removing the Printed Circuit Board	4-3
Replacing the EPROM	4-4
Installing an Option Card	4-5
Replacing the LCD Display	4-6
Installing the Printed Circuit Board	4-7
Spare Parts	4-9

Appendix A: Service Record

Introduction	A-1
Data Entry	A-1
Diagnostic Parameters	A-3

Table of Contents (cont.)

Appendix B: Optional Enclosures

Introduction	B-1
Rack Mount Enclosure	B-1
Rack Mount Fuse Replacement	B-2
Rack Mount Option Card Installation	B-3
Rack Mount EPROM Replacement	B-5
Rack Mount LCD Display Replacement	B-6
Rack Mount Printed Circuit Board Replacement	B-7
Circuit Board Removal	B-7
Circuit Board Installation	B-8

Chapter 1

Calibration

Introduction.....	1-1
Menu Map	1-1
Calibrating the Analog Outputs	1-2
Calibrating the Analog Inputs.....	1-6
Calibrating the RTD Inputs.....	1-9
Testing the Alarm Relays	1-11
Testing the Totalizer/Frequency Outputs.....	1-13

Introduction

Calibrating the Model GC868's analog outputs and inputs is explained in this chapter. In addition, testing the optional totalizer/frequency and alarm relay outputs is discussed. The following specific topics are included:

- calibrating the built-in Slot 0 analog outputs
- calibrating optional Slot 1 through Slot 6 analog outputs
- calibrating optional Slot 1 through Slot 6 analog inputs
- testing optional Slot 1 through Slot 6 alarm relays
- testing optional Slot 1 through Slot 6 totalizer/frequency outputs.

The Model GC868 electronics console includes six expansion slots for the installation of option cards. These slots are numbered 1-6, from right to left. In addition, every Model GC868 flowmeter includes two built-in analog outputs (A and B) at terminal block I/O, which is designated as Slot 0.

Note: *Convention in this manual identifies any expansion slot as Slot x, where x is a number from 0-6.*

See Chapter 1, *Installation*, of the *Startup Guide* for a complete description of the available option cards and the procedures for wiring them.

Menu Map

The *Calibration Menu* is accessed by pressing the [CAL] key on the keypad. Use this menu to calibrate and test the Slot 0 analog outputs, as well as to calibrate and test any option cards that are installed in the expansion slots. Refer to the menu map in Figure 1-6 on page 1-15 as a guide in following the calibration instructions.

Note: *The same instructions apply to both the 1-Channel and 2-Channel versions of the Model GC868 flowmeter.*

The following discussion assumes that the left screen pane is active. If the right screen pane is active, only the function key designations change. That is, replace [F1]-[F4] with [F5]-[F8]. Proceed to the appropriate sections of this chapter to calibrate and test all of the installed inputs and/or outputs.

Note: *While in the Calibration Menu, if there is no keypad activity for two minutes, the Model GC868 will automatically reboot and return to measurement mode.*

Calibrating the Analog Outputs

Every Model GC868 flowmeter includes two built-in analog outputs (A and B) at terminal block I/O, which is designated as Slot 0. Additional analog outputs may be added to the Model GC868 by installing an *Analog Outputs Option Card* in one (or more) of the six expansion slots. Each option card contains four analog outputs, which are designated as A, B, C and D. Both the zero-point and full-scale values for each output must be calibrated. After calibrating the outputs, which have a resolution of 5.0 μA (0.03% full scale), their linearity should be tested.

Note: *The zero point of the analog output may be set for either 0 mA or 4 mA. However, the calibration procedure always uses the 4 mA point, as the meter will extrapolate from this value to obtain the 0 mA point.*

Prepare for the calibration procedure by connecting an ammeter to the desired analog output of Slot X, as shown in Figure 1-1 below and Figure 1-2 on the next page. Refer to the menu map in Figure 1-6 on page 1-15.

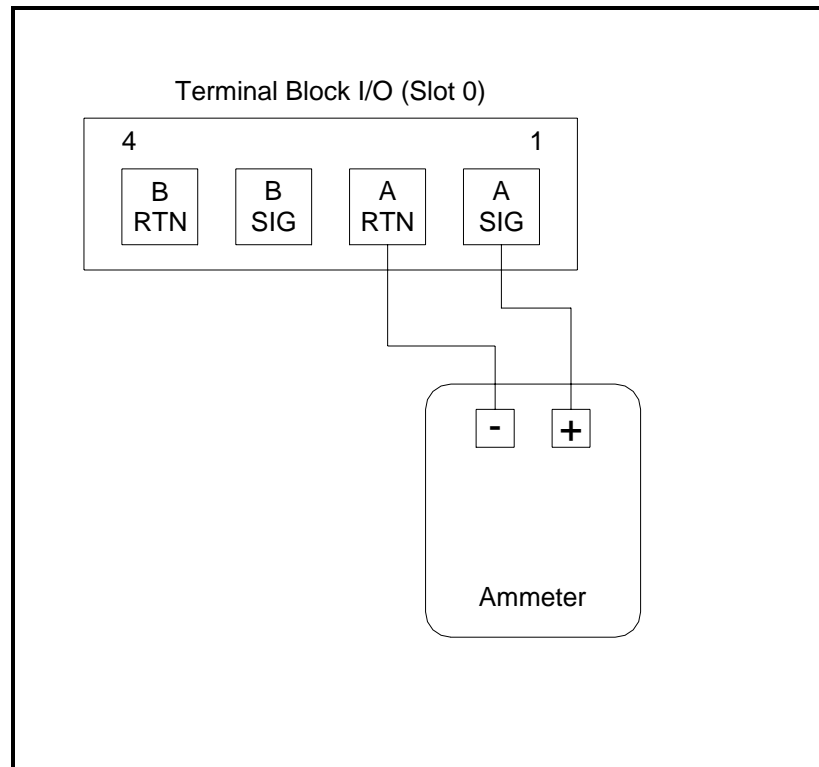

Figure 1-1: Ammeter Connection (Output A)

Calibrating the Analog Outputs (cont.)

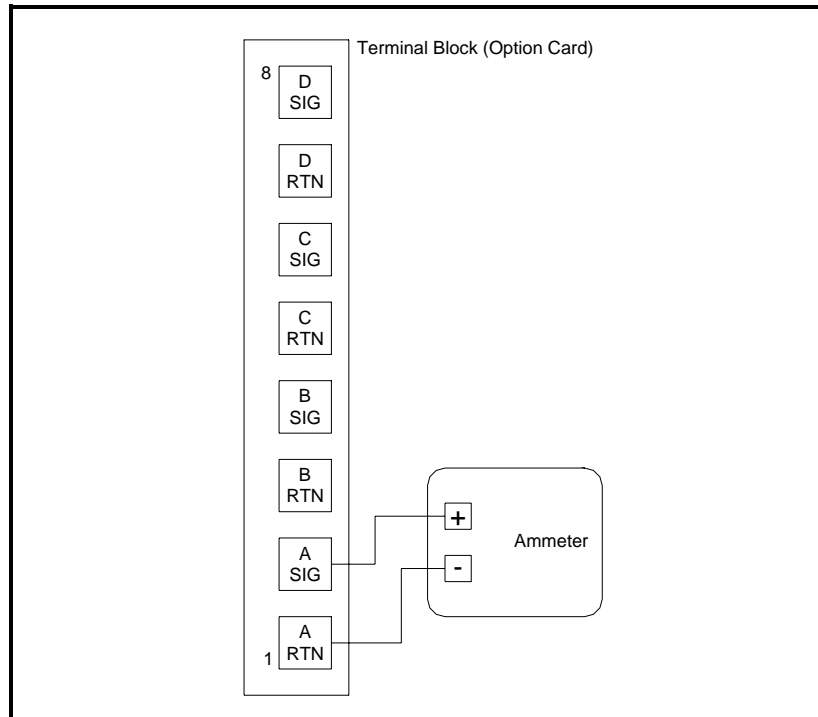

Figure 1-2: Ammeter Connection for Slots 1-6 (Output A)

Accessing the Calibration Menu

1. Press the [CAL] key to enter the *Calibration Program*.
2. Press [Fx] to calibrate the desired slot. (The option bar will include a slot listing for each installed option card.)
3. Press [Fx] to select the desired output.

IMPORTANT: *The procedure for calibrating all the outputs is the same. However, when calibrating a different output, be sure to reconnect the ammeter to the appropriate pins on terminal block I/O. See Figure 1-1 on page 1-2 or Figure 1-2 above for the correct pin numbers.*

Calibrating the Low End of the Output Range

1. Press [F1] to calibrate the low end of the output range.
2. Press [F1] or [F2] to adjust the ammeter reading UP or DOWN, until a 4 mA reading is achieved. If you press [F3], Numer, enter a numeric value for the calibration point and press [ENT].
3. Press [F4] to STORE the setting, or press → and [F1] to ABORT the calibration.

Note: *If the ammeter reading cannot be adjusted within 5.0 μ A of the 4 mA setting, contact the factory for assistance.*

Calibrating the High End of the Output Range

1. Press [F2] to calibrate the high end of the output range.
2. Press [F1] or [F2] to adjust the ammeter reading UP or DOWN, until a 20 mA reading is achieved. If you press [F3], Numer, enter a numeric value for the calibration point and press [ENT].

Note: *If the ammeter reading cannot be adjusted within 5.0 μ A of the 20 mA setting, contact the factory for assistance.*

3. Press [F4] to STORE the setting, or press → and [F1] to ABORT the calibration.

Note: *Skip the next section if the linearity test will not be performed at this time. Proceed to What's Next? on the next page.*

Testing the Analog Output Linearity

Note: *If you exited this menu and are returning, follow steps 1 through 3 in Accessing the Calibration Menu on page 1-3.*

1. Press [F3] to TEST the linearity of the currently selected analog output.
2. Check the ammeter reading at the 50% output level.
3. Then, enter a different output level (0-100%) and press [ENT].
4. Check the ammeter reading at this setting and press [ENT] when done.

Table 1-1 on the next page lists the expected ammeter readings at various % Full Scale settings, for both 4-20 mA and 0-20 mA scales. Refer to this table to verify the accuracy of the ammeter readings taken above.

Calibrating the Analog Outputs (cont.)

Table 1-1: Expected Ammeter Readings

% Full Scale	4-20 mA Scale*	0-20 mA Scale*
0	4.000	0.000
10	5.600	2.000
20	7.200	4.000
30	8.800	6.000
40	10.400	8.000
50	12.000	10.000
60	13.600	12.000
70	15.200	14.000
80	16.800	16.000
90	18.400	18.000
100	20.000	20.000
* All ammeter readings should be ± 0.005 mA		

If the linearity test readings are not within $5 \mu\text{A}$ of the values listed in Table 1-1 above, check the accuracy and wiring of the ammeter. Then, repeat the low and high end calibrations. If the analog output still does not pass the linearity test, contact the factory for assistance.

What's Next?

You have completed calibration of the analog output. Do one of the following:

- To calibrate or test another output, press [F4] (EXIT) and return to Step 3 in *Accessing the Calibration Menu* on page 1-3.
- To calibrate/test additional slots, press [F4] (EXIT) twice and proceed to the appropriate section.
- To leave the Calibration Menu, press [F4] (EXIT) three times.

Calibrating the Analog Inputs

Analog inputs may be added to the Model GC868 flowmeter by installing an *Analog Inputs Option Card* in one (or more) of the six expansion slots. The option card contains two analog inputs, which are designated as A and B. Each of the inputs, which may be either a 0/4-20 mA input or an RTD input, must be calibrated at both the zero-point and full-scale values. After calibrating the inputs, their linearity should be tested.

Calibration of the analog inputs requires the use of a calibrated current source. If an independent calibrated current source is not available, one of the Slot 0 analog outputs may be used for the calibration. During the analog input calibration, the Slot 0 analog output will supply the low reference, high reference, 4 mA and 20 mA signals at the appropriate times.

Note: *If a Slot 0 analog output is used to calibrate the analog inputs, make sure that the Slot 0 analog output calibration procedure has already been completed.*

Connect the Slot 0 analog output(s) (or an independent calibrated current source) to the analog input(s) on the option card, as shown in Figure 1-3 below. Refer to the menu map in Figure 1-6 on page 1-15 as a guide.

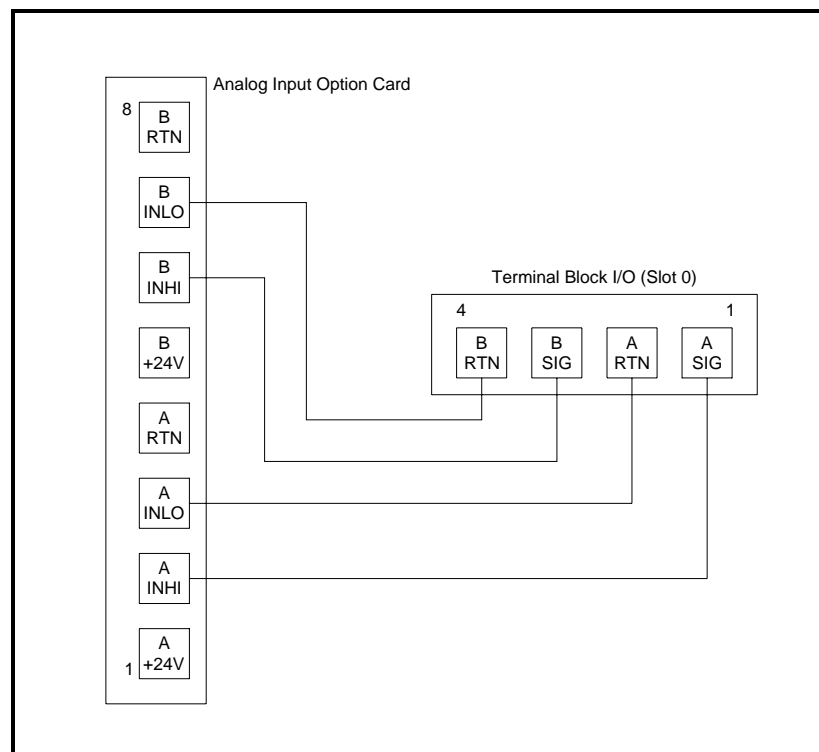

Figure 1-3: Analog Input Calibration Connections

Calibrating the Analog Inputs (cont.)

For this discussion, assume that the option card has been installed in Slot x.

Note: *The zero point of the analog input may be set for either 0 mA or 4 mA. However, the calibration procedure always uses the 4 mA point, as the meter will extrapolate from this value to obtain the 0 mA point.*

Accessing the Calibration Menu

1. Press the [CAL] key to enter the *Calibration Program*.
2. Press [Fx] to calibrate the desired slot. (The option bar will include a slot listing for each installed option card.)
3. Press [Fx] to select the desired input.

The procedure for calibrating Input A is identical to that for calibrating Input B. However, when calibrating Input B, be sure a calibrated current source is connected to the appropriate pins on the terminal block. See Figure 1-3 on the previous page for the correct pin numbers. To calibrate a 0/4-20 mA input card, see the section below.

Note: *To calibrate an RTD input card, refer to page 1-9.*

4. Press [F1]-[F4] to select the reference point to be calibrated.

Do one of the following:

- If you selected [F1] (aLOW), proceed to aLOW Option on the next page.
- If you selected [F2] (aHIGH), proceed to aHIGH Option on the next page.
- If you selected [F3] (4 mA), proceed to 4 mA Option on the next page.
- If you selected [F4] (20 mA), proceed to 20 mA Option on the next page.

aLOW Option = [F1]

1. Enter the low reference value and press the [ENT] key.
2. Press [F1] to store the current low reference value or press [F2] to cancel the entry. In either case, the ANALOG INPUT prompt will reappear.
3. Press [F2] to proceed to the next section.

aHIGH Option = [F2]

1. Enter the high reference value and press the [ENT] key.
2. Press [F1] to store the current high reference value or press [F2] to cancel the entry. In either case, the ANALOG INPUT prompt will reappear.
3. Proceed to What's Next? below.

4 mA Option = [F3]

1. Connect the 4 mA current source to the currently selected analog input, as shown in Figure 1-3 on page 1-6.
2. Press [F1] to store the current 4 mA value or press [F2] to cancel the entry. In either case, the ANALOG INPUT prompt reappears.
3. Press [F4] to proceed to the next section.

20 mA Option = [F4]

1. Connect the 20 mA current source to the currently selected analog input, as shown in Figure 1-3 on page 1-6.
2. Press [F1] to store the current 20 mA value or press [F2] to cancel the entry. In either case, the ANALOG INPUT prompt reappears.
3. Proceed to What's Next? below.

What's Next?

You have completed calibration of the analog output. Do one of the following:

- To calibrate another input, return to Step 3 in *Accessing the Calibration Menu* on the previous page.
- To calibrate/test additional slots, press [F4] (EXIT) and proceed to the appropriate section.
- To leave the Calibration Menu, press [F4] (EXIT) twice.

Calibrating the RTD Inputs

Calibrating an RTD option card involves a different procedure than for other analog input cards. However, you access the card in the same manner as other cards.

Accessing the Calibration Menu

1. Press the [CAL] key to enter the *Calibration Program*.
2. Press [Fx] to calibrate the desired slot. (The option bar will include a slot listing for each installed option card.)

If you have installed an RTD option card, the following screen appears:

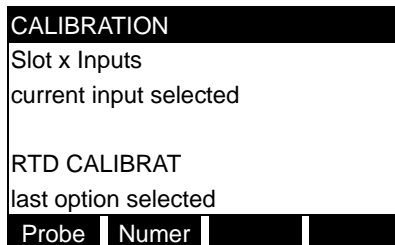

Press [F1] to select the Probe method of calibration, or [F2] to select the numeric method.

The Probe option allows the meter to calculate the temperature vs. resistance curve, based on input from the RTD in a temperature bath or from an RTD calibrator. The Numer option forces the user to calculate and input the curve values numerically.

IMPORTANT: *Use only one option for RTD calibration. Do not try to calibrate with both options.*

Probe Option = [F1]

3. Press [F1] to select Input A, or [F2] to select Input B.

Set Point Temperature

4. Press [F1] to enter the set point temperature (formerly known as the zero point). This temperature should be at the low end of your expected operating range.
5. Enter the desired set point temperature, and press [ENT].
6. Press [F1] to STORE the entered temperature, or [F2] to ABORT the calibration. In either case, the screen returns to the ANALOG INPUT prompt.

Slope Point Temperature

7. Press [F2] to enter the slope point temperature. This temperature should be as far from your set point as your temperature bath will allow, within the range -100° to +350°C (-148° to +592°F).
8. Enter the desired slope point temperature, and press [ENT].
9. Press [F1] to STORE the entered temperature, or [F2] to ABORT the calibration. In either case, the screen returns to the ANALOG INPUT prompt.
10. Proceed to *What's Next?* on the next page.

Numer Option = [F2]

The Numer option allows the user to calculate the temperature vs. resistance information. To do this, the user must first collect data using the RTDs option in the PRINT menu (discussed in Chapter 5 of the *Programming Manual*). The RTDs option allows you to know what point value the GC868 is reading at a given temperature. With this information, the Numer option enables you to enter the Set Temperature and the slope of the RTD input in points/degree, allowing absolute control over RTD calibration. Before attempting this step, follow the instructions in Chapter 5 of the *Programming Manual* (“The RTDs Submenu”) to obtain point values at your set point and slope point.

Set Number

1. Press [F1] to select Input A, or [F2] to select Input B.
2. Press [F1] to enter the set number (formerly known as the zero point).
3. Enter the set point temperature, and press [ENT].
4. The program then asks for the set point number. Enter the points measured at the set temperature, and press [ENT].

Slope Number

5. Press [F2] to enter the slope number. Calculate the slope number with the formula:

$$\text{Slope} = \frac{\text{Slope point} - \text{set point}}{\text{slope temp} - \text{set temp}} \quad (1-1)$$

6. Enter the RTD slope number and press [ENT].

What's Next?

You have completed calibration of the RTD input. Do one of the following:

- To calibrate another input, press [EXIT].
- To calibrate additional slots, press [EXIT] and then [F4] (EXIT) and proceed to the appropriate section.
- To leave the Calibration Menu, press [F4] (EXIT) twice.

Testing the Alarm Relays

Alarm relays may be added to the Model GC868 by installing an *Alarms Option Card* in one (or more) of the six expansion slots. Each option card includes three alarm relays, which are designated as A, B, and C. To test the alarm relays, connect an ohmmeter to the option card terminal block as shown in Figure 1-4 below. Refer to the menu map in Figure 1-6 on page 1-15 as a guide.

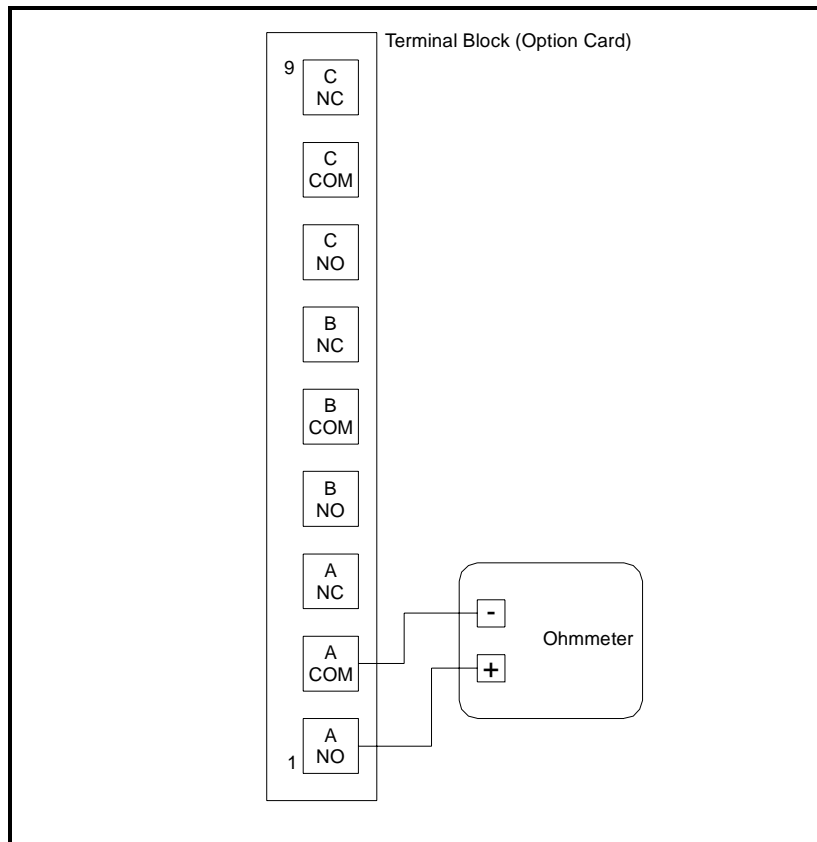

Figure 1-4: Typical Ohmmeter Connections

For this discussion, assume that the option card has been installed in Slot x.

Accessing the Calibration Menu

1. Press the [CAL] key to enter the *Calibration Program*.
2. Press [Fx] to calibrate the desired slot. (The option bar will include a slot listing for each installed option card.)
3. Press [F1]-[F3] to select alarm relay A, B or C, respectively.

Testing the Alarm Relays (cont.)

Note: *The procedure for testing Alarm Relay A is identical to that for testing Alarm Relays B and C. However, make sure that the ohmmeter is connected to the desired normally-open or normally-closed contact of the currently selected relay. See Figure 1-4 on page 1-11 for the correct pin numbers on the option card terminal block.*

4. Pressing [F1] (CLOSE) should yield an ohmmeter reading of about zero. Pressing [F2] (OPEN) should yield an infinite ohmmeter reading.
5. Press [F3] to EXIT.
6. Repeat the above procedure until both the normally-open and normally-closed contacts for all three alarm relays have been tested. Then proceed to What's Next? below.

What's Next?

You have completed testing the alarm relays. Do one of the following:

- To calibrate/test additional slots, press [F4] (EXIT) and proceed to the appropriate section.
- To leave the Calibration Menu, press [F4] (EXIT) twice.

Testing the Totalizer/ Frequency Outputs

Totalizer/frequency outputs may be added to the Model GC868 by installing a *Totalizer/Frequency Option Card* in one (or more) of the six expansion slots. Each option card includes four outputs, which are designated as A, B, C and D. To test the outputs, connect a frequency counter to the card's terminal block as shown in Figure 1-5 below. Refer to the menu map in Figure 1-6 on page 1-15 as a guide.

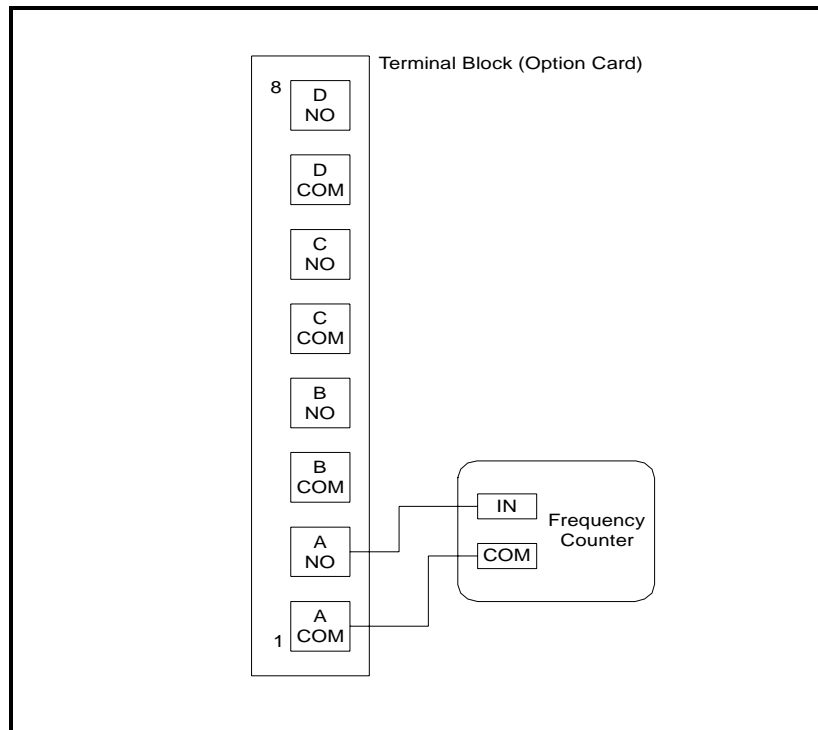

Figure 1-5: Frequency Counter Connections

For this discussion, assume that the option card has been installed in Slot x.

Accessing the Calibration Menu

1. Press the [CAL] key to enter the *Calibration Program*.
2. Press [Fx] to calibrate the desired slot. (The option bar will include a slot listing for each installed option card.)
3. Press [F1]-[F4] to select output A, B, C or D, respectively.

Entering Frequency

4. Enter a new frequency in the range of 1-10,000 Hz and press the [ENT] key. Verify that the frequency counter reads the correct value.

Entering Pulse Number

5. Enter the number of pulses desired (between 1 and 10,000) and press the [ENT] key. That number of pulses will then be output at the specified frequency.
6. Repeat Steps 3, 4 and 5 to test all four of the frequency/totalizer outputs. If any of the outputs fails to pass the test, contact GE Infrastructure Sensing for assistance.

What's Next?

You have completed testing the totalizer/frequency outputs. Do one of the following:

- To calibrate/test additional slots, press [F4] (EXIT) and proceed to the appropriate section.
- To leave the Calibration Menu, press [F4] (EXIT) twice.

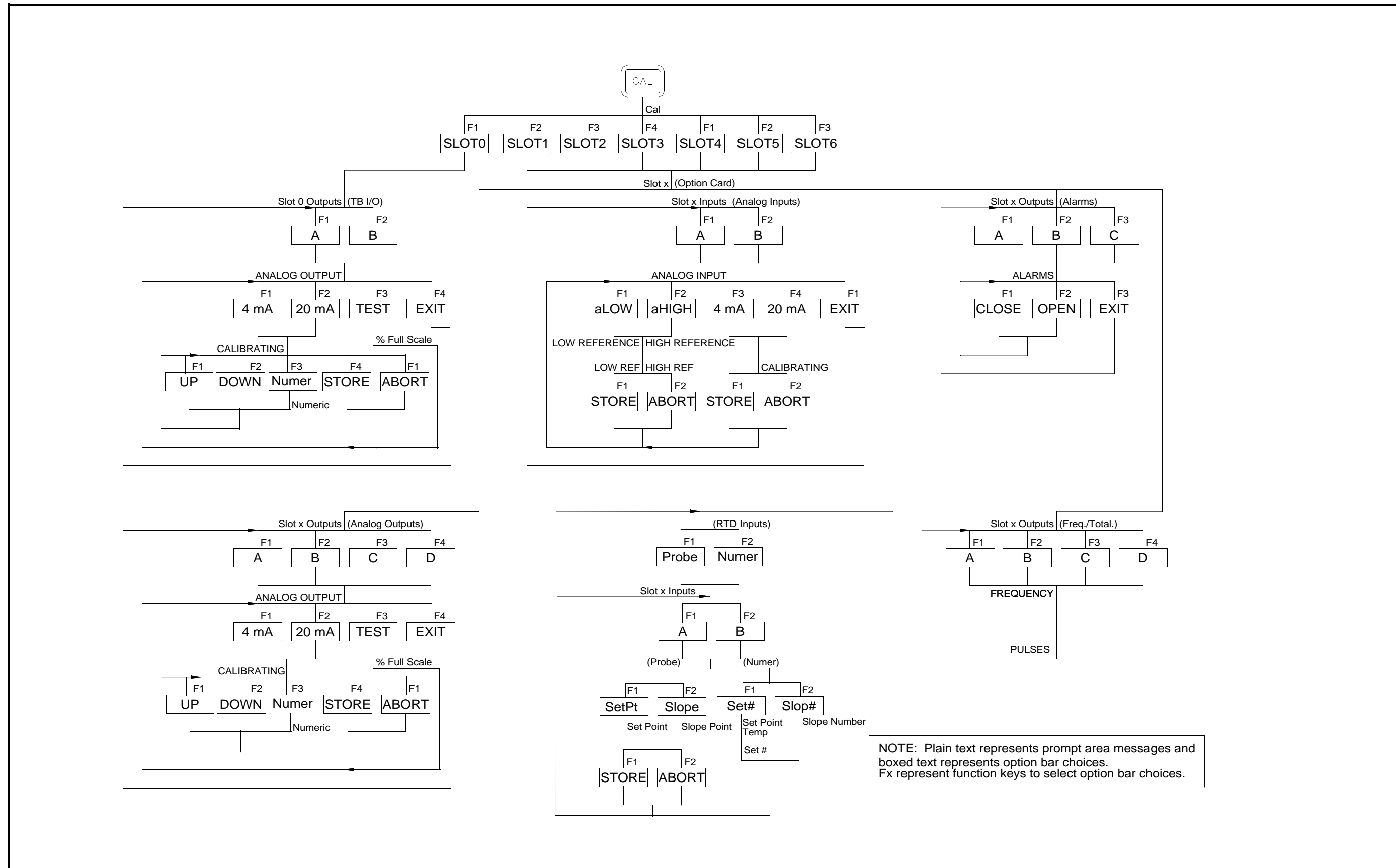

Figure 1-6: Calibration Menu Map

Chapter 2

Error Codes and Screen Messages

- Introduction..... 2-1
- E0: No Error 2-2
- E1: Low Signal 2-2
- E2: Sound Speed Error..... 2-2
- E3: Velocity Range 2-2
- E4: Signal Quality 2-3
- E5: Amplitude Error 2-3
- E6: Cycle Skip, Accel. 2-3
- E7: Analog Out Error 2-3
- E8: Temp In..... 2-3
- E9: Press In..... 2-4
- E10: Special Input..... 2-4
- E11: Not Used 2-4
- E12: Not Used 2-4
- E13: Over Range 2-4
- E14: Totals Overflow 2-4
- E15: Equation Limit 2-4
- E16: High Signal 2-5
- Screen Messages 2-5

Introduction

The Model GC868 ultrasonic flowmeter is a reliable, easy to maintain instrument. When properly installed and operated, as described in the *Startup Guide*, the meter provides accurate flow rate measurements with minimal user intervention. However, if a problem should arise with the electronics console, the transducers or the flowcell, a built-in error code message system greatly simplifies the troubleshooting process.

All of the possible Model GC868 error code messages are discussed in this chapter, along with the possible causes and the recommended actions. When an error code is generated, it will appear on the active pane of the display screen in the location shown in Figure 2-1 below.

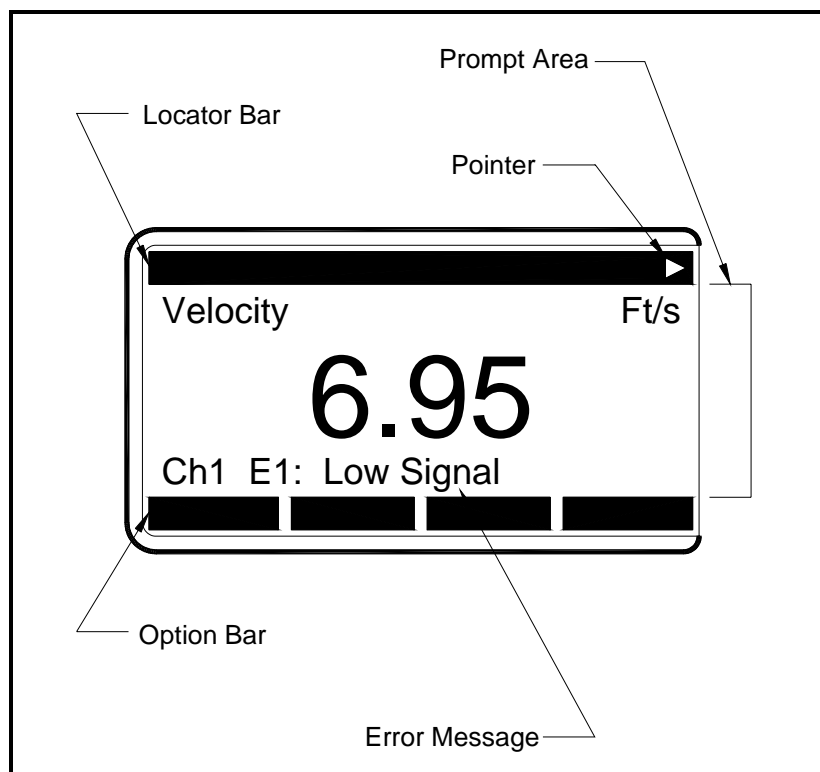

Figure 2-1: A Typical Display Screen

Note: For a 2-Channel Model GC868, the channel number is displayed in front of the error message. Only the error message appears with a 1-Channel Model GC868.

If an error message appears on the display screen during operation of the Model GC868, refer to the appropriate section of this chapter for instructions on how to proceed.

E0: No Error

Problem: No error condition currently exists.

Cause: This message appears briefly to confirm that the cause for a previous error condition has disappeared, has cleared or been resolved.

Action: No action is required.

E1: Low Signal

Problem: Poor ultrasonic signal strength or the signal exceeds the limits entered via the *User Program*.

Cause: Poor signal strength may be caused by a defective cable, preamplifier or decoupler, a flowcell problem, a defective transducer or a problem in the electronics console. A signal that exceeds the programmed limits is probably caused by the entry of an improper value in the PIPE or SETUP SIGNAL submenus of the *User Program*.

Action: Using the procedures in Chapter 3, *Diagnostics*, check the components listed above. Also, check the value programmed into the PIPE or SETUP SIGNAL submenu, as described in the *Operator's Manual*.

E2: Sound Speed Error

Problem: The sound speed exceeds the limits programmed in the SETUP SIGNAL submenu of the *User Program*.

Cause: The error may be caused by incorrect programming, poor flow conditions, wrong transducer spacing or poor coupling.

Action: Compare the measured sound speed to tabulated nominal values for the fluid being used and correct any programming errors. Refer to Chapter 3, *Diagnostics*, to correct any flowcell and/or transducer problems.

E3: Velocity Range

Problem: The velocity exceeds the limits programmed in the SETUP submenu of the *User Program*.

Cause: This error may be caused by the entry of improper programming data or by poor flow conditions and/or excessive turbulence.

Action: Make sure the actual flow rate is within the programmed limits. See the *Programming Manual* for details. Refer to Chapter 3, *Diagnostics*, to correct any flowcell and/or transducer problems.

E4: Signal Quality	<p>Problem: The signal quality is outside the limits programmed in the SETUP submenu of the <i>User Program</i>.</p> <p>Cause: Too high a signal strength may be caused by the failure of an electronic component. Too low a signal strength may be caused by a flowcell or electrical problem. Another cause may be a poor signal-to-noise ratio for the measure mode cycle count technique.</p> <p>Action: Check for sources of electrical interference and verify the integrity of the electronics console by temporarily substituting a test flowcell that is known to be good. Check the transducers and relocate them, if necessary. See Chapter 3, <i>Diagnostics</i>, for instructions.</p>
E5: Amplitude Error	<p>Problem: The signal amplitude exceeds the limits programmed in the SETUP submenu of the <i>User Program</i>.</p> <p>Cause: Excessive levels of an attenuating gas, such as CO₂, are present in the pipe. Solid or liquid particulates may be present in the pipe. The problem could also be caused by excessive turbulence levels or rapid pressure variations.</p> <p>Action: Refer to Chapter 3, <i>Diagnostics</i>, to correct any flowcell problems.</p>
E6: Cycle Skip, Accel.	<p>Problem: The acceleration exceeds the limits programmed in the SETUP submenu of the <i>User Program</i>.</p> <p>Cause: This condition is usually caused by poor flow conditions or improper transducer spacing.</p> <p>Action: Refer to Chapter 3, <i>Diagnostics</i>, to correct any flowcell and/or transducer problems.</p>
E7: Analog Out Error	<p>Problem: The current in the analog output circuit exceeds the limits for the analog output port.</p> <p>Cause: The output load exceeds the specified limits for the analog output port.</p> <p>Action: Make sure the output load is <550 ohms for the Slot 0 analog outputs or is <1000 ohms for an analog outputs option card (slots 1-6).</p>
E8: Temp In	<p>Problem: This message indicates a temperature input error.</p> <p>Cause: The temperature exceeds the specified limits for the analog inputs option card.</p> <p>Action: Check the temperature transmitter and the connecting cable. Refer to Chapter 1, <i>Calibration</i>, and recalibrate the analog inputs on the option card.</p>

E9: Press In	Problem: This message indicates a pressure input error. Cause: The pressure exceeds the specified limits for the analog inputs option card. Action: Check the pressure transmitter and the connecting cable. Refer to Chapter 1, <i>Calibration</i> , and recalibrate the analog inputs on the option card.
E10: Special Input	Problem: This message indicates a special input error. Cause: The special input exceeds the specified limits for the analog inputs option card. Action: Check the special transmitter and the connecting cable. Refer to Chapter 1, <i>Calibration</i> , and recalibrate the analog inputs on the option card.
E11: Not Used	This error code message is not currently in use.
E12: Not Used	This error code message is not currently in use.
E13: Over Range	Problem: This error code message indicates that the present measurement exceeds the capacity of the meter. Cause: An internal mathematical overflow has occurred in either the volumetric or mass flow calculations. Action: Select larger measurement units or a shorter time interval for the current measurement parameter. For example, choose KSCF/M instead of SCF/M. See the <i>Startup Guide</i> for instructions.
E14: Totals Overflow	Problem: The totalizers are unable to keep up with the total flow signals. Cause: The programmed units/pulse value is too small. Action: Select a larger number of units/pulse value.
E15: Equation Limit	Problem: The steam measurement may not be within 1% accuracy. Cause: The temperature or pressure reading is outside the accuracy specification of the GC868 steam equations. Action: Adjust the pressure reading to within the range of 139.9685 kPa to 2242.9435 kPa (20.8717 to 326.4482 psi), or the temperature reading to within the range of 373.1500°K to 810.9278°K (100 to 212°F).

E16: High Signal

Problem: The meter signal strength exceeds the limits entered via the *User Program*.

Cause: A signal that exceeds the programmed limits is probably caused by the entry of an improper value in the TRANSDUCER or PIPE submenu of the *User Program*.

Action: Check the values programmed into the TRANSDUCER and PIPE submenus, as described in the *Startup Guide* and the *Programming Manual*. Bypass or remove the preamp.

Screen Messages

A variety of messages may appear on the display screen during the performance of a task. Since the error codes have already been discussed in this chapter and the locator bar messages are discussed in detail in Chapter 3, *Operation*, of the *Startup Guide*, they will not be repeated here. All other messages are listed in Table 2-1 below.

Table 2-1: Screen Messages

Message	Meaning
Power Up Messages	
Backup Battery FAIL	The backup battery that powers the non-volatile RAM has failed. Contact the factory.
Backup Battery OK	The backup battery that powers the non-volatile RAM has passed.
EPROM sum = XXXX	Record the EPROM sum at the initial power up and periodically thereafter.
FRIGID_INIT Executed	The NVR (non-volatile RAM) was automatically initialized due to a memory fault. Contact the factory.
NVR FAIL	The non-volatile RAM has failed. Contact the factory.
NVR OK	The non-volatile RAM has passed.
Measurement Mode Messages	
All Logs Cleared! hit key	This message may appear during one of the following tasks: 1. clearing a log - there are no more logs to clear 2. logging data - user has hit [ENT] instead of selecting an old log or entering a new name 3. printing a log - there are no logs to print 4. displaying a log - there are no logs to display Hit any key to resume taking measurements.

Table 2-1: Screen Messages (Continued)

Message	Meaning
All Sites Cleared! hit key	This message may appear during one of the following tasks: <ol style="list-style-type: none"> 1. saving a new site - a new site name was not entered or overwrite existing site was not selected 2. recalling a site - there are no site files to recall 3. clearing a site - there are no sites to delete 4. printing a site - there are no sites to print 5. displaying a site - there are no sites to display Hit any key to resume taking measurements.
Do you want to SAVE?	This message appears upon exiting the <i>User Program</i> , if the new site data has not been saved. Failure to save will result in loss of the new data next time the site data is changed or recalled.
Duplicate name, Enter another.	The site file or log name is already in use. Enter a different name.
End Time must exceed Start Time by 5 min.	This message appears when in the LOG menu. Enter an end time that is at least five minutes later than the start time.
Header invalid	An option card error indicating a programming failure or a loss of memory. Contact the factory.
Log Active, END only hit any key	When in the LOG menu, this message indicates that the log is still compiling data. Only the End Time may be edited.
Log DONE, to inspect hit any key	When in the LOG menu, this message indicates that the log is complete. Hit any key to display the log.
Log hasn't started! hit key	When in the LOG menu, this message indicates that the log has not yet started.
OK, settling	The measurement has not stabilized. Wait before taking a reading.
Outside limits, value rejected.	When in the CAL menu, this message indicates that the calibration of the analog output is invalid. Hit any key to clear the message, and the GC868 will default to the last valid calibration. The message will also appear if there is no ammeter connected to the analog output during calibration.
Overflow	The display value overflowed. Reduce the number of decimal digits or change the units.
??P<L Enter L again.	The entered path length (P) is less than the axial dimension (L). Enter a new value for L.
range is X.XX to X.XX	When in the <i>User Program</i> , this message indicates that the entered number is unacceptable. Hit any key and enter a number within the allowable range.
Review calibration	An option card error indicating a programming failure or a loss of memory. Contact the factory.
Review parameters	An option card error indicating a programming failure or a loss of memory. Contact the factory.

Table 2-1: Screen Messages (Continued)

Message	Meaning
Starting time must exceed current time	This message appears when in the LOG menu STD option. Enter a start time that is later than the current time.
Write error.	An option card error indicating a programming failure or a loss of memory. Contact the factory.

Chapter 3

Diagnostics

Introduction.....	3-1
Displaying Diagnostic Parameters	3-1
Diagnostic Record	3-4
Flowcell Problems.....	3-4
Transducer Problems	3-6

Introduction

This chapter explains how to troubleshoot the Model GC868 if problems arise with the electronics console, the flowcell, or the transducers. Indications of a possible problem include:

- display of an error message on the active display screen
- erratic flow readings
- readings of doubtful accuracy (i.e., readings that are not consistent with readings from another flow measuring device connected to the same process).

If any of the above conditions occurs, proceed with the instructions presented in this chapter.

Displaying Diagnostic Parameters

The Model GC868 has a built-in *Diagnostics Menu* to aid in the troubleshooting of flowcell, transducer and/or electrical problems. The *Diagnostics Menu* may only be entered from the *Big* or *Dual* measurement mode display. See Chapter 2, *Displaying Data*, in the *Programming Manual* for instructions on setting the display screen to the desired format, and enter the *Diagnostics Menu* as shown below.

1. For a 2-channel GC868, press the [←] or [→] keys until the desired channel option appears on the option bar. Press the appropriate [Fx] key to select this option.

Note: *For a 1-Channel Model GC868, the above prompt does not appear, and the following prompt is the initial screen.*

2. Press the [←] or [→] keys until DIAG appears on the option bar. Press the appropriate [Fx] key to select this option.

Note: *Ch1 (or Ch2), which is shown in parentheses above, appears in the locator bar only with a 2-Channel Model GC868.*

For example, pressing [F1] displays the Tdown parameter, as shown in the following prompt.

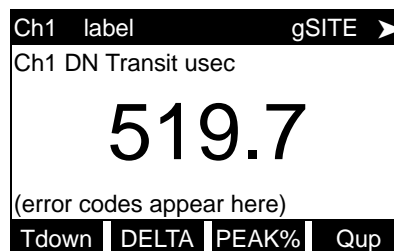

Press the [←] and [→] keys and the appropriate [Fx] key to display a different diagnostic parameter or to EXIT the *Diagnostics Menu*.

Displaying Diagnostic Parameters (cont.)

Table 3-1 below lists the available diagnostic parameters for the Model GC868. The first column in the table shows the parameter as it appears on the option bar, while the second column shows the parameter as it appears in the prompt area after it has been selected.

Table 3-1: Available Diagnostic Parameters

Option Bar	Screen Display	Description	Good	Bad
SS up	UP Sig Strength	Displays the signal strength for the upstream transducer.	58–68	<58 or >68
SS do	DN Sig Strength	Displays the signal strength for the downstream transducer.	58–68	<58 or >68
SNDSP	Soundspeed Ft/s	Displays the measured sound speed of the fluid.	N.A.	N.A.
Tup	UP Transit S usec	Displays the upstream transit time of the ultrasonic signal in microseconds.	N.A.	N.A.
Tdown	DN Transit usec	Displays the downstream transit time of the ultrasonic signal in microseconds.	N.A.	N.A.
DELTA	DeltaT usec	Displays the difference in μ sec between the upstream and downstream transit times.	N.A.	>30 nsec
REYN#	Reynolds #	Displays the Reynolds number.	<100,000,000	N.A.
Tot K	K(Re) MultiK*KFactor	Displays the combination of all K factors.	N.A.	N.A.
PEAK%	PEAK%	Displays the percentage of peak (set to +80 by default).	N.A.	N.A.
Qup	UP Signal Q	Displays the signal quality for the upstream transducer.	$\geq 1,200$	-400 to +400
Qdown	DN Signal Q	Displays the signal quality for the downstream transducer.	$\geq 1,200$	-400 to +400
AMPup	UP Amp Discrim	Displays the value for the amplitude discriminator of the upstream transducer.	24 ± 5	<19 or >29
AMPdn	DN Amp Discrim	Displays the value for the amplitude discriminator of the downstream transducer.	24 ± 5	<19 or >29
CNTup	UP DAC Counts	Displays the AGC DAC count for upstream gain setting.	N.A.	N.A.
CNTdn	DN DAC Counts	Displays the AGC DAC count for downstream gain setting.	N.A.	N.A.
P#up	UP +- Peak	Displays signal peaks for the upstream transducer.	100-2,300	<100 or >2,300

Table 3-1: Available Diagnostic Parameters (Continued)

Option Bar	Screen Display	Description	Good	Bad
P#dn	DN +- Peak	Displays signal peaks for the downstream transducer.	100-2,300	<100 or >2,300
TEMP	Temperature deg F	Displays the gas temperature (0/4-20 mA or RTD input).	N.A.	N.A.
PRES	Pressure psia	Displays the gas pressure (0/4-20 mA or RTD input).	N.A.	N.A.
Fpv	SuperC	Displays supercompressibility as calculated by the NX19 equation or custom table.	N.A.	N.A.
AcVOL	Act Vol. KACF/MIN	Displays actual volumetric flow.	N.A.	N.A.
StVOL	Std Vol. KSCF/MIN	Displays standard volumetric flow, if STANDARD equation is used.	N.A.	N.A.
Tu S*	UP Transit S usec	Displays Skan Tup.	N.A.	N.A.
Td S*	DN Transit S usec	Displays Skan Tdn.	N.A.	N.A.
DT S*	DeltaT S usec	Displays Skan DELTA	N.A.	N.A.
Tu M*	UP Transit M usec	Displays Measure Tup	N.A.	N.A.
Td M*	DN Transit M usec	Displays Measure Tdn	N.A.	N.A.
DT M*	DeltaT M usec	Displays Measure Delta	N.A.	N.A.
ToffS*	Skan T Offset usec	Displays dynamically calculated signal timing offset in the skan signal measurement.	N.A.	N.A.
Vinst	Vinst. Ft/s	Displays the instantaneous velocity for comparison with Vel without averaging.	N.A.	N.A.
THETA	Theta 3 degrees	Displays the angle of the ultrasonic signal inside the pipe.	N.A.	N.A.
CEE1	CEE1	Displays the speed of sound in the transducer (clamp-on only).	N.A.	N.A.
SNRup	UP Signal/noise	Displays the signal/noise ratio for the upstream transducer.	>7	<7
SNRdn	DN Signal/noise	Displays the signal/noise ratio for the downstream transducer.	>7	<7
S-MDT	SkanDT-MeasDT	Displays the difference between the Skan Delta T and Measure Delta T values.	N.A.	N.A.
EXIT	Last parameter	Leave the Diagnostics Menu	N.A.	N.A.
* These options are available only in the Skan/Measure mode.				

Diagnostic Record

Upon leaving the *Diagnostic Menu* via the [EXIT] key or the EXIT option on the option bar, the display screen will continue to show the last diagnostic parameter that was selected. To return to normal measurement mode, select a channel to display (for a 2-Channel meter only) and then select the desired display parameter. See Chapter 3, *Operation*, of the *Startup Guide* for detailed instructions.

The values for the diagnostic parameters immediately after initial installation of the meter and verification of proper operation should be entered in Table A-2 in Appendix A, *Service Record*. These values can then be compared to future values to help diagnose any future malfunction of the system.

Flowcell Problems

If preliminary troubleshooting with the *Error Code Messages* and/or the *Diagnostic Menu* indicates a possible flowcell problem, proceed with this section. Flowcell problems fall into two categories:

- gas problems
- pipe problems.

Read the following sections carefully to determine if the problem is indeed related to the flowcell. If the instructions in this section fail to resolve the problem, contact GE Infrastructure Sensing for assistance.

Gas Problems

Most gas-related problems result from a failure to observe the flowmeter system installation instructions, as described in the *Startup Guide*. Refer to Chapter 1, *Installation*, of the *Startup Guide* to correct any installation problems.

If the physical installation of the system meets the recommended specifications, it is possible that the gas itself may be preventing accurate flow rate measurements. The gas being measured must meet the following requirements:

1. *The gas must be homogeneous, single-phase and relatively clean.* Although a low level of entrained particles may have little effect on the operation of the Model GC868, excessive amounts of solid or liquid particles will absorb or disperse the ultrasound signals. This interference with the ultrasound transmissions through the gas will cause inaccurate flow rate measurements. In addition, temperature gradients in the gas flow may result in erratic or inaccurate flow rate readings.

Gas Problems (cont.)

2. *The gas must not excessively attenuate ultrasound signals.*
Some gases (i.e., high-purity carbon dioxide, hydrogen, etc.) readily absorb ultrasound energy. In such a case, an E1 error code message will appear on the display screen to indicate that the ultrasonic signal strength is insufficient for reliable measurements.
3. *The gas sound speed must not vary excessively.*
The Model GC868 will tolerate relatively large changes in the gas sound speed, as may be caused by variations in gas composition and/or temperature. However, such changes must occur slowly. Rapid fluctuations in the gas sound speed, to a value that is considerably different from that programmed into the Model GC868, will result in erratic or inaccurate flow rate readings. Refer to Chapter 2, *Initial Setup*, of the *Startup Guide* and make sure that the appropriate sound speed is programmed into the meter.

Pipe Problems

Pipe-related problems may result either from a failure to observe the installation instructions, as described in the *Startup Guide*, or from improper programming of the meter. By far, the most common pipe problems are the following:

1. *The collection of material at the transducer location(s).*
Accumulated debris at the transducer location(s) will interfere with transmission of the ultrasound signals. As a result, accurate flow rate measurements are not possible. Realignment of the flowcell or transducers often cures such problems. Refer to Chapter 1, *Installation*, of the *Startup Guide* for more details on proper installation practices.
2. *Inaccurate pipe measurements.*
The accuracy of the flow rate measurements is no better than the accuracy of the programmed pipe dimensions. For a flowcell supplied by GE Infrastructure Sensing, the correct data will be included in the documentation. For other flowcells, measure the pipe wall thickness and diameter with the same accuracy desired in the flow rate readings. Also, check the pipe for dents, eccentricity, weld deformity, straightness and other factors that may cause inaccurate readings. Refer to Chapter 2, *Initial Setup*, of the *Startup Guide* for instructions on programming the pipe data.

Transducer Problems

Ultrasonic transducers are rugged, reliable devices. However, they are subject to physical damage from mishandling and chemical corrosion. The most common transducer problems are listed below:

- 1. LEAKS:** Leaks may occur around the transducer. Repair such leaks immediately. If the leaking gas is corrosive, carefully check the transducer and cables for damage, after the leak has been repaired.
- 2. CORROSION DAMAGE:** If the transducer material was not properly chosen for the intended application, the transducers may suffer corrosion damage. The damage usually occurs either at the electrical connector or on the transducer surface. If corrosion is suspected, remove the transducer from the flowcell and carefully inspect the electrical connector and the transducer surface for roughness and/or pitting. Any transducer damaged in this manner must be replaced. Contact GE Infrastructure Sensing for information on transducers in materials suitable for the application.
- 3. INTERNAL DAMAGE:** An ultrasonic transducer consists of a ceramic crystal bonded to the transducer case. The bond between the crystal and the case, or the crystal itself may be damaged by extreme mechanical shock and/or temperature extremes. Also, the internal wiring can be corroded or shorted if contaminants enter the transducer housing.
- 4. PHYSICAL DAMAGE:** Transducers may be physically damaged by dropping them onto a hard surface or striking them against another object. The transducer connector is the most fragile part and is the one most subject to damage. Minor damage may be repaired by carefully bending the connector back into shape. If the connector cannot be repaired, the transducers must be replaced.

Note: *Transducers must be replaced in pairs. Refer to Chapter 2, Initial Setup, of the Startup Guide to program the replacement transducer data into the meter.*

If the instructions in this section fail to resolve the problem, contact GE Infrastructure Sensing for assistance.

Chapter 4

Parts Replacement

- Introduction..... 4-1
- Fuse Replacement 4-2
- Removing the Printed Circuit Board 4-3
- Replacing the EPROM 4-4
- Installing an Option Card 4-5
- Replacing the LCD Display..... 4-6
- Installing the Printed Circuit Board 4-7
- Spare Parts 4-9

Introduction

The electronics console of the Model GC868 has been designed to permit easy on-site upgrades and parts replacement. See Figure 4-1 on page 4-10 and Figure 4-2 on page 4-11 for details of the standard GC868 electronics console assembly. The instructions in this chapter, along with a few common tools, are all that is required to perform the following tasks:

- fuse replacement
- printed circuit board (PCB) removal and installation
- EPROM replacement
- option card installation
- LCD display replacement

IMPORTANT: *For meters supplied in any of the optional enclosure types, see Appendix B, Optional Enclosures, for instructions specific to that unit.*

!WARNING!

Prior to performing any maintenance procedures, be sure to disconnect the main power from the unit.

Note: *For compliance with the European Union's Low Voltage Directive (73/23/EEC), this unit requires an external power disconnect device such as a switch or circuit breaker. The disconnect device must be marked as such, clearly visible, directly accessible, and located within 1.8 m (6 ft) of the Model GC868.*

An aluminum shroud over the printed circuit board shields the electrical components and serves as a location for the wiring diagram label. All of the procedures discussed in this chapter, except for fuse replacement, require removal of this shroud.

Note: *For compliance with the European Union's Low Voltage Directive (73/23/EEC), a transparent plastic shroud protects the electrical connections. The shroud must remain in place, except while wiring the unit. Reinstall the shroud after the wiring has been completed.*

Use the foldout drawings at the end of this chapter to locate the relevant components, while completing the following procedures.

IMPORTANT: *Keep a detailed record of all service procedures performed on the Model GC868 in Appendix A, Service Record. This service history may prove very helpful in diagnosing any future problems.*

Fuse Replacement

If it has been determined that the fuse in the Model GC868 requires replacement, complete the following steps:

1. Remove the main power to the electronics console.

!WARNING!

The main power to the Model GC868 must be disconnected before proceeding.

2. Open the cover on the electronics console. For LVD compliant units, remove the two mounting screws and lift the clear plastic shroud out of the electronics console.
3. Locate the black plastic fuse holder that is mounted on the printed circuit board between the power terminal block (TB1) and the RS232 terminal block. As shown in Figure 4-1 on page 4-10, the fuse holder extends below the main aluminum shroud, and the fuse holder cap is located on the bottom of the fuse holder.
4. Using a small standard screwdriver, turn the fuse holder cap counterclockwise about 1/4 turn. The fuse holder cap, with the captive fuse, will be ejected from the fuse holder.
5. Replace the defective fuse with a new one of the same rating and type. Use only 1-1/4" x 1/4" Slo-Blo fuses, having a rating as indicated in Table 4-1 below and on the wiring diagram label.

Table 4-1: Line Voltages & Fuse Ratings

Line Voltage	Fuse Rating
100-120 VAC	1.0 A, Slo-Blo
220-240 VAC	0.5 A, Slo-Blo
12-28 VDC	3.0 A, Slo-Blo

6. Press the new fuse into the fuse holder cap and insert the fuse into the fuse holder. While applying a slight pressure with the screwdriver, twist the fuse holder cap 1/4 turn clockwise.
7. For LVD compliant units, place the clear plastic shroud over the standoffs in the electronics console and secure it in place with its two mounting screws. Close the cover on the electronics console.

The Model GC868 flowmeter may now be placed back into service. Reconnect the main power and resume taking measurements.

Note: *Be sure to record the fuse replacement in Appendix A, Service Record.*

Removing the Printed Circuit Board

All of the remaining maintenance procedures discussed in this chapter require removal of the printed circuit board. To accomplish this task, refer to Figure 4-1 on page 4-10 and Figure 4-2 on page 4-11 while completing the following tasks:

1. Remove the main power to the electronics console.

!WARNING!

The main power to the Model GC868 must be disconnected before proceeding.

2. Open the electronics console. For LVD compliant units, remove the two mounting screws and lift the clear plastic shroud out of the electronics console. Remove the six mounting screws and lift the main aluminum shroud out of the electronics console.
3. Disconnect the main power leads from terminal block TB1 on the printed circuit board. Remove the electrical connectors from all installed option cards and terminal blocks. Disconnect the twisted-pair display backlight cable from connector J2 on the left side of the printed circuit board.
4. Using a 3/8 in. nutdriver or open-end wrench, remove the three short standoffs along the left side of the main circuit board and the three long standoffs along the right side of the main circuit board.
5. While supporting the printed circuit board, remove the two screws or standoffs along the bottom edge of the printed circuit board.

Note: *For an LVD compliant meter with the clear plastic shroud over the electrical connectors, there will be standoffs in these two locations. For meters not equipped with this shroud, there will be Phillips head screws in these two locations.*

Caution!

During this procedure, be very careful not to damage the upright components along the top edge of the printed circuit board (see Figure 4-2 on page 4-11). Severe or repeated bending of these components will break their leads.

6. On newer units, unscrew the green grounding strap from its location between the fuse holder and power terminal block, taking care not to lose the attached washer and nut.
7. Carefully lift the printed circuit board out of the enclosure. Continue to support the printed circuit board, as the keypad and display cables are still connected to the bottom of the board.

Removing the Printed Circuit Board (cont.)

8. Tilt the top of the printed circuit board forward, and mark the top edges of the two ribbon-cable connectors. Then, remove these cables from their connectors on the rear of the board.
9. The printed circuit board is now free and may be removed to a clean work area.

If the printed circuit board is being replaced, proceed to the section on *Installing the Printed Circuit Board* (page 4-7) now. Otherwise, refer to the appropriate section for instructions on *Installing an Option Card* (page 4-5), *Replacing the EPROM* (below), or *Replacing the LCD Display* (page 4-6).

Replacing the EPROM

The Model GC868's *User Program* is stored on an erasable programmable read only memory (EPROM) chip. The EPROM, which is designated as component U4, is located in the top left corner of the bottom of the printed circuit board. See Figure 4-2 on page 4-11 for a rear view of the printed circuit board. EPROM replacement may be required to replace a defective chip or to upgrade to a newer software version. To replace the EPROM, complete the following steps:

1. Remove the printed circuit board, as described in a previous section of this chapter.
2. Place the printed circuit board face down on a clean, flat surface. Locate the EPROM socket at the top left corner of the board.

Caution!

The EPROM is easily damaged by static electricity. Before handling the new chip, touch a grounded metal object to discharge any built-up static electricity and avoid touching the leads on the side of the chip.

3. Using a chip puller, remove the EPROM from its socket. If a chip puller is unavailable, a straightened paper clip may be used in the notches at the upper right and lower left corners of the socket. Gently pry the EPROM up, a little at a time, at each notch until it comes free.
4. Make sure that the beveled corner on the new EPROM is aligned with the beveled corner of the socket and place the EPROM into the socket.
5. By applying equal pressure on all four corners, gently press the EPROM into the socket until it is fully seated. Do not strike the EPROM or apply excessive force during this procedure.

Complete the EPROM replacement by proceeding to the *Installing the Printed Circuit Board* section of this chapter (page 4-7).

Installing an Option Card

The Model GC868 flowmeter can accommodate up to six option cards. The option cards are installed into sockets on the bottom of the printed circuit board, and they are held in place with a metal bracket. A single metal bracket is used to secure all the installed option cards.

Note: *If the Model GC868 presently has no option cards installed, be sure to purchase the metal mounting bracket along with the first option card.*

To install an option card, refer to Figure 4-2 on page 4-11 and complete the following steps:

1. Remove the printed circuit board, as described in a previous section of this chapter.
2. If one or more option cards are already installed, remove the four fasteners that secure the metal bracket to the printed circuit board. Lift the metal bracket straight up and away from the printed circuit board.

Note: *The fasteners may be either plastic snap rivets or metal hardware (in some older meters). In either case, they may be discarded, as new plastic snap rivets are provided.*

3. There are six 32-pin option card sockets (J41–J46) on the rear of the printed circuit board. To install an option card, insert its 32-pin connector into any available option card socket and gently press the card into place. Make sure that the pins in the connector are straight and properly aligned with the socket and that the connector is positioned on the right side of the option card.

Caution!

Do not force the option card into the socket. If the card does not enter the socket easily, check for and straighten any bent pins in the connector and try again.

4. Repeat step 3 to install any additional option cards.
5. Place the metal bracket over the option cards, making sure that all option cards are aligned with the plastic card guides in the bracket. Secure the metal bracket to the printed circuit board with the snap rivets provided. See the installed assembly in Figure 4-1 on page 4-10.

Complete the option card installation by proceeding to the *Installing the Printed Circuit Board* section on page 4-7 of this chapter.

Replacing the LCD Display

The Model GC868's measurements are displayed on a two-pane LCD graphic display panel. The LCD display normally provides years of dependable service, but it is easily field-replaceable when necessary. To replace the LCD display, see Figure 4-1 on page 4-10 for the component locations, and complete the following steps:

1. Remove the printed circuit board, as described in a previous section of this chapter.
2. Using a 3/16" nutdriver, remove the four nut/washer sets that secure the display shroud to the inside of the console cover. Lift the display shroud off its mounting studs.
3. Using a 1/4" nutdriver, remove the four standoffs that secure the LCD display assembly to the console cover. Lift the LCD display assembly off its mounting studs.
4. Place the new LCD display assembly over the mounting studs on the console cover and fasten it in place with the four standoffs. Make sure that the LCD display assembly is oriented as shown in Figure 4-2 on page 4-11.

Caution!

Do not overtighten the standoffs or the display assembly may be damaged.

5. Position the LCD display cables between the two right side mounting studs, and install the display shroud over the mounting studs. The top and bottom edges of the shroud are bent at a 90° angle to the main surface, and these edges must face inwards toward the display assembly.

Note: *One edge of the display shroud is covered with a piece of black electrical tape. This side of the shroud should be on the right, to protect the cables against abrasion.*

6. Fasten the display shroud to the console cover with the four sets of nuts/washers.

Caution!

Do not overtighten the nuts or damage to the mounting threads may occur.

Complete the LCD Display replacement by proceeding to the *Installing the Printed Circuit Board* section on the next page.

Installing the Printed Circuit Board

Whether the printed circuit board was removed for replacement or for one of the other procedures discussed in this chapter, reinstallation of the printed circuit board is the final step in the process. Refer to Figure 4-1 on page 4-10 and complete the following steps:

Caution!

During this procedure, be very careful not to damage the vertical components along the top edge of the printed circuit board (see Figure 4-2 on page 4-11). Severe or repeated bending of these components will break their leads.

1. Position the printed circuit board within the electronics console with the top edge tilted forward. Insert the display ribbon cable and keypad ribbon cable connectors into their sockets on the rear of the printed circuit board. See Figure 4-1 on page 4-10 and Figure 4-2 on page 4-11 to identify the cables and sockets. Note that the keypad cable connects to the upper socket and the display cable connects to the lower socket.

IMPORTANT: *The ribbon cables must be installed with the edges that were marked during removal oriented toward the top of the printed circuit board.*

2. Carefully position the printed circuit board up against the eight standoffs in the enclosure. Do not damage the transformers and any installed option cards as they are maneuvered between the standoffs.
3. Loosely install the three long standoffs on the right side of the printed circuit board and the two standoffs (or screws) along the bottom edge of the printed circuit board. Then, install only the top and bottom short standoffs on the left side of the printed circuit board.
4. Insert the free end of the green grounding strap between the printed circuit board and the middle standoff beneath the left side of the board. Making sure to capture the grounding strap lug between the printed circuit board and the standoff beneath it, install the remaining short standoff on the left side of the printed circuit board. Securely tighten all eight standoffs and/or screws.

IMPORTANT: *Correctly installing the grounding strap may require some patience, but resist the temptation to place the grounding strap on top of the printed circuit board. On newer units, screw the grounding strap into its hole between the fuse holder and the power terminal block with the screw, washer and nut.*

Installing the Printed Circuit Board (cont.)

5. Connect the twisted-pair backlight cable to socket J2 on the left edge of the printed circuit board. This plug is polarized so that it can only be installed in the proper orientation, with the black wire above the red wire.
6. Check for and remove any loose hardware that may have fallen into the electronics console during the maintenance procedure.
7. Place the main shroud over the six upper standoffs on the printed circuit board. Making sure that the shroud is oriented with the wiring diagram label upright, fasten the shroud to the standoffs with the six sets of screws and washers.
8. Reconnect the power line wires to terminal block TB1 on the printed circuit board. Plug all other electrical connectors into the appropriate sockets on the printed circuit board and option cards. See Chapter 1, *Installation*, of the *Startup Guide* for instructions on proper wiring of the Model GC868.

Note: *For an LVD compliant meter with the clear plastic shroud over the electrical connectors, there will be standoffs in the two mounting locations along the bottom edge of the printed circuit board. For meters not equipped with this shroud, there will be Phillips head screws in these two locations.*

9. For LVD compliant units, position the clear plastic LVD shroud over the electrical connections so that the two holes in the shroud align with the standoffs on the printed circuit board. Secure the shroud to the standoffs with the two sets of screws and washers.
10. After carefully checking for and removing any loose hardware in the enclosure, close the electronics console and reconnect the main power to the Model GC868.

Note: *For compliance with the European Union's Low Voltage Directive (73/23/EEC), this unit requires an external power disconnect device such as a switch or circuit breaker. The disconnect device must be marked as such, clearly visible, directly accessible, and located within 1.8 m (6 ft) of the Model GC868.*

Before taking measurements with the Model GC868, refer to Chapter 2, *Initial Setup*, of the *Startup Guide* and Chapter 1, *Calibration*, of the *Service Manual* for instructions on properly setting up the meter for accurate flow rate measurements.

Note: *Be sure to enter a complete and detailed account of the service procedure performed on the Model GC868 in Appendix A, Service Record.*

Spare Parts

All of the necessary components to upgrade or repair the Model GC868 flowmeter are readily available from GE Infrastructure Sensing. As a convenient reference, some of the more common spare parts are listed in Table 4-2 below.

Table 4-2: Spare Parts List

Part Number	Description
703-1127-02	Option Card - Alarms, Hermetically Sealed
703-1127-03	Option Card - Alarms, General Purpose
703-1442-02	Option Card - Analog Inputs
703-1326-02	Option Card - Analog Outputs
703-1442-03	Option Card - RTD Inputs
703-1144-02	Option Card - Totalizer/Frequency Outputs
703-1358	Option Card - MODBUS
421-703	Card Cage (Metal Bracket)
417-027	Card Guide, Nylon
703-1247	Printed Circuit Board
705-671	LCD Display Assembly
147-744	EPROM
421-700	Conduit Plate, 1/2"
421-701	Conduit Plate, 3/4"
421-702	Conduit Plate, Blank
421-946	LVD Plastic Shroud
421-686	Main Aluminum Shroud
442-484	Label, Wiring Diagram

To purchase the parts listed in Table 4-2 above or any items not listed in the table, contact GE Infrastructure Sensing for assistance. To make sure the proper components are obtained, be sure to specify the *serial number* of the Model GC868 at the time of purchase.

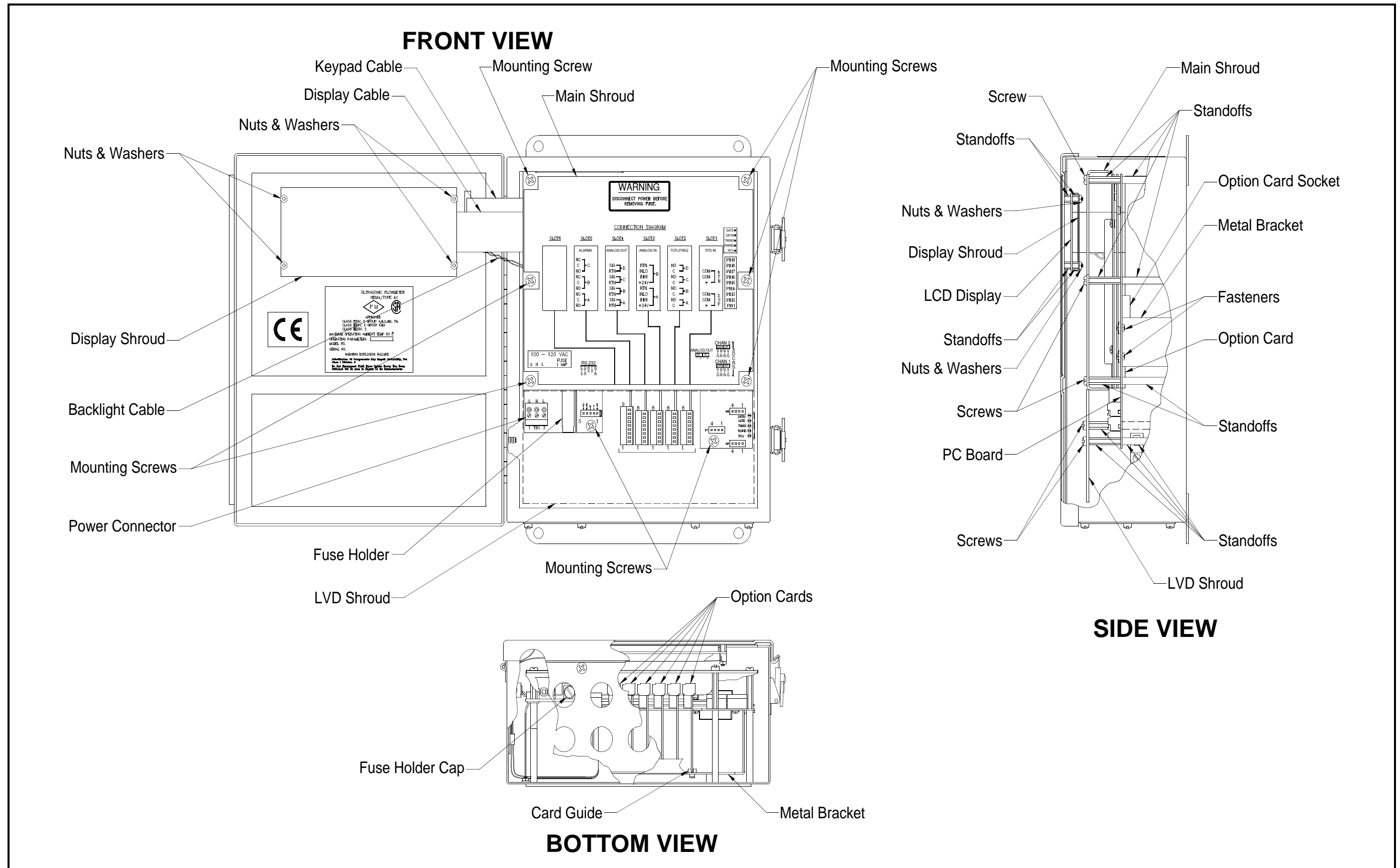

Figure 4-1: Standard Model GC868 - Electronics Console Assembly

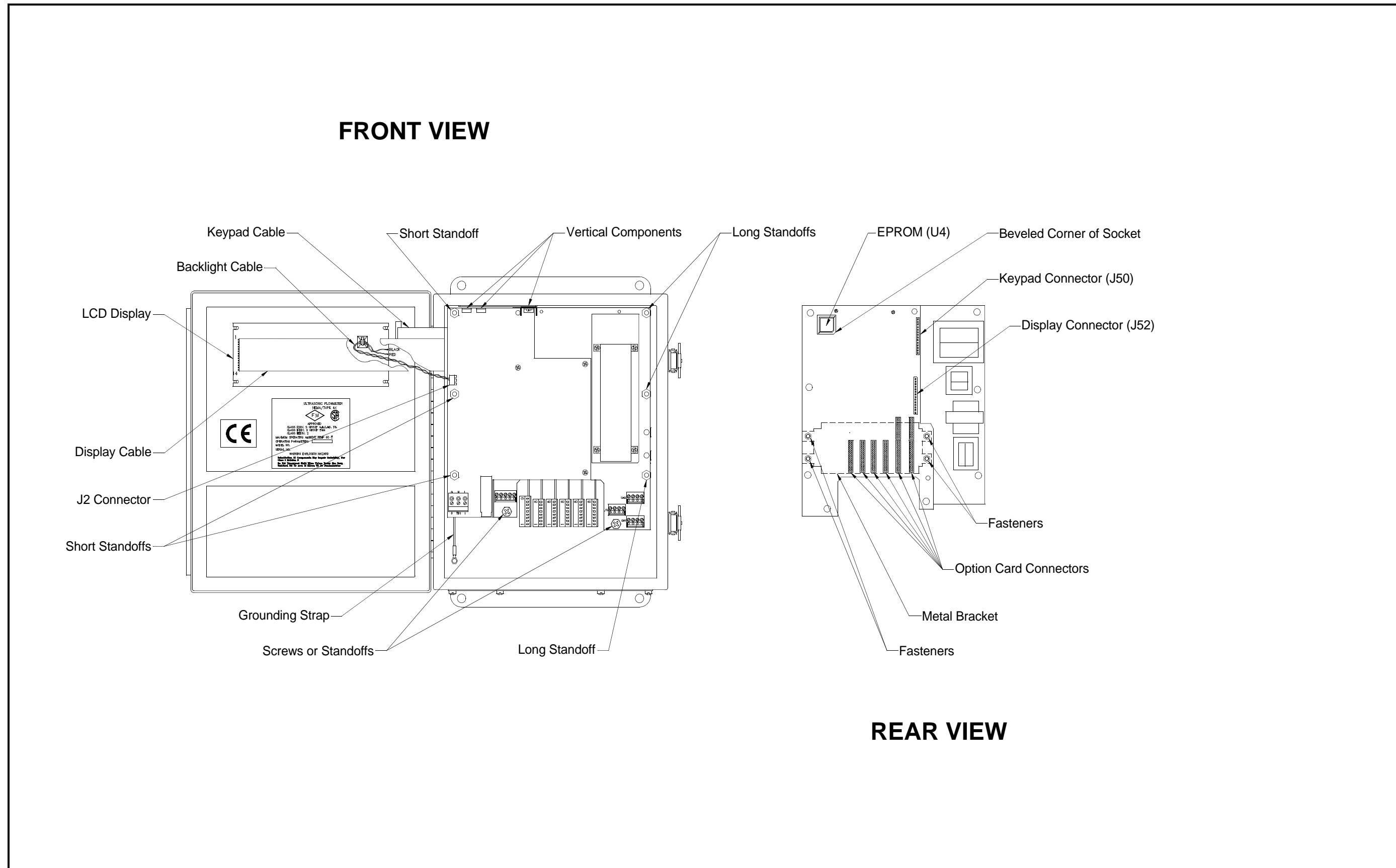

Figure 4-2: Standard Model GC868 - Printed Circuit Board Assembly

Appendix A

Service Record

Introduction.....A-1

Data EntryA-1

Diagnostic Parameters

After a successful initial installation of the Model GC868 and whenever any system malfunction is noticed, the values for the diagnostic parameters should be entered in Table A-2 below.

Table A-2: Diagnostic Parameters

Parameter	Initial	Current	Parameter	Initial	Current
SS up			Mw		
SS do			AcVOL		
SNDSP			StVOL		
Tup			Tu S*		
Tdown			Td S*		
DELTA			DT S*		
PEAK%			Tu M*		
Qup			Td M*		
Qdown			DT M*		
AMPup			ToffS*		
AMPdn			Vinst		
CNTup			THETA		
CNTdn			CEE1		
P#up			SNRup		
P#dn			SNRdn		
TEMP			S-MDT		
PRES					
*available only in Skan/Measure mode					

Appendix B

Optional Enclosures

- Introduction..... B-1
- Rack Mount Enclosure..... B-1
- Rack Mount Fuse Replacement..... B-2
- Rack Mount Option Card Installation B-3
- Rack Mount EPROM Replacement B-5
- Rack Mount LCD Display Replacement..... B-6
- Rack Mount Printed Circuit Board Replacement..... B-7

Introduction

The Model GC868 is available in optional enclosure types, each of which has been designed to permit easy on-site upgrades and parts replacement. See the foldout drawings at the end of this appendix for details of the applicable GC868 electronics console assembly. The instructions in this appendix, along with a few common tools, are all that is required to perform the following tasks:

- fuse replacement
- option card installation
- EPROM replacement
- LCD display replacement
- printed circuit board (PCB) replacement

IMPORTANT: *For meters supplied in the standard NEMA-4X enclosure, see Chapter 4, Parts Replacement, for instructions specific to that unit.*

!WARNING!

Prior to performing any maintenance procedures, disconnect the main power from the unit.

Note: *For compliance with the European Union's Low Voltage Directive (73/23/EEC), this unit requires an external power disconnect device such as a switch or circuit breaker. The disconnect device must be marked as such, clearly visible, directly accessible, and located within 1.8 m (6 ft) of the Model GC868.*

Rack Mount Enclosure

Refer to Figure B-1 on page B-10 and Figure B-2 on page B-11 for the location of the relevant components, while completing the following procedures. If the top panel of the meter is accessible, service may be performed without removing the meter from the rack. Otherwise, disconnect all rear panel electrical connections and remove the meter from the rack before proceeding.

IMPORTANT: *Keep a detailed record of all service procedures in Appendix A, Service Record. This record may prove very helpful in diagnosing any future problems.*

Rack Mount Fuse Replacement

If it has been determined that the fuse in the Model GC868 requires replacement, see Figure B-1 on page B-10 and Figure B-2 on page B-11, and complete the following steps:

1. On the rear panel of the meter, set the power switch to the OFF position and pull the power cord out of its receptacle.

!WARNING!

The main power to the Model GC868 must be disconnected before proceeding.

2. Locate the black plastic fuse cover on the back panel at the bottom of the power cord receptacle and pull it straight out.
3. Replace the defective fuse with a new one of the same rating and type. Use only 5 x 20 mm Slo-Blo fuses, having a rating as indicated in Table B-1 below and on the rear panel label.

Table B-1: Line Voltages & Fuse Ratings

Line Voltage	Fuse Rating
100-120 VAC	1.0 A, Slo-Blo
220-240 VAC	0.5 A, Slo-Blo
12-28 VDC	3.0 A, Slo-Blo

4. Reinstall the black plastic fuse cover and insert the power cord back into the receptacle. Then, position the power switch in the ON position.

The Model GC868 flowmeter may now be placed back into service. Reconnect the main power and resume taking measurements.

Note: *Be sure to record the fuse replacement in Appendix A, Service Record.*

Rack Mount Option Card Installation

The Model GC868 flowmeter can accommodate up to six option cards in a manner similar to that used in a PC. The option cards are installed into sockets on the printed circuit board, and they are held in place with a metal bracket. A single metal bracket is used to secure all the installed option cards.

Note: *If the Model GC868 presently has no option cards installed, be sure to purchase the metal mounting bracket along with the first option card.*

Refer to Figure B-2 on page B-11 and complete the following steps:

1. After disconnecting the main power to the meter, remove the *top panel* from the enclosure by removing the four screws indicated.

!WARNING!

The main power to the Model GC868 must be disconnected before proceeding.

2. If one or more option cards are already installed, remove the four *fasteners* that secure the metal bracket to the printed circuit board. Lift the *metal bracket* straight up and away from the printed circuit board.

Note: *The fasteners may be either plastic snap rivets or metal hardware (in some older meters). In either case, they may be discarded, as new plastic snap rivets are provided.*

3. There are six 32-pin *option card sockets* (J41–J46) on the rear of the printed circuit board. By removing the screw on the rear panel, remove the appropriate *option slot cover* to make room for the external connector on the new option card.
4. To install the *option card*, insert its 32-pin connector into the chosen option card socket and gently press the card into place. Make sure that the pins in the connector are straight and properly aligned with the socket and that the option card is oriented with its external connector positioned in the opening on the rear panel.

Caution!

Do not force the option card into the socket. If the card does not enter the socket easily, check for and straighten any bent pins in the connector and try again.

5. Repeat steps 3 and 4 to install any additional option cards.

Rack Mount Option Card Installation (cont.)

6. Place the metal bracket over the option cards, making sure that all installed option cards are inserted into the plastic card guides in the bracket. The bracket must be oriented so that the six card guides are directly above the six sockets on the printed circuit board (*do not* install the bracket rotated 180° out of position). Secure the metal bracket to the printed circuit board with the four plastic snap rivets provided.
7. After checking for any loose hardware that may have fallen into the enclosure, reinstall the top panel on the meter and secure the panel in place with the four screws previously removed.

The Model GC868 flowmeter may now be placed back into service. Reconnect the main power and refer to Appendix C, *Optional Enclosures*, of the *Startup Guide* for instructions on wiring the new option card(s).

Note: *Be sure to record the option card installation in Appendix A, Service Record.*

Rack Mount EPROM Replacement

The Model GC868's *User Program* is stored on an erasable programmable read only memory (EPROM) chip. The EPROM, which is designated as component U4, is located on the corner of the printed circuit board just behind the keypad on the front panel.

EPROM replacement may be required to replace a defective chip or to upgrade to a newer software version. To replace the EPROM, refer to Figure B-2 on page B-11 and complete the following steps:

1. After disconnecting the main power to the meter, remove the top panel from the enclosure by removing the four screws indicated.

!WARNING!

The main power to the Model GC868 must be disconnected before proceeding.

2. Using a chip puller, remove the EPROM from its socket. If a chip puller is unavailable, a straightened paper clip may be used in the notches at opposite corners of the socket. Gently pry the EPROM up, a little at a time, at each notch until it comes free.

Caution!

The EPROM is easily damaged by static electricity. Before handling the new chip, touch a grounded metal object to discharge any built-up static electricity and avoid touching the leads on the side of the chip.

3. Make sure that the beveled corner on the new EPROM is aligned with the beveled corner of the socket and place the EPROM into the socket.
4. By applying equal pressure on all four corners, gently press the EPROM into the socket until it is fully seated. Do not strike the EPROM or apply excessive force during this procedure.
5. After checking for any loose hardware that may have fallen into the enclosure, reinstall the top panel on the meter and secure the panel in place with the four screws previously removed.

The Model GC868 flowmeter may now be placed back into service. Reconnect the main power and resume taking measurements.

Note: *Be sure to record the EPROM replacement in Appendix A, Service Record.*

Rack Mount LCD Display Replacement

The Model GC868 measurements are displayed on a two-pane LCD graphic display panel. The LCD display normally provides years of dependable service, but it is field-replaceable when necessary.

To replace the LCD display, refer to Figure B-2 on page B-11 and complete the following steps:

1. After disconnecting the main power to the meter, remove the top panel from the enclosure by removing the four screws indicated.

!WARNING!

The main power to the Model GC868 must be disconnected before proceeding.

2. Using a 3/16" nutdriver, remove the four nut/washer sets that secure the display shroud to the inside of the front panel. Pull the display shroud off its mounting studs.
3. Using a 1/4" nutdriver, remove the four standoffs that secure the LCD display assembly to the front panel. Pull the LCD display assembly off its mounting studs.
4. Place the new display in the enclosure and replace the circuit board connections of the data and power cables of the old display with those of the new display. Be sure to orient the new cables in the same way as the old ones, when making the connections to the printed circuit board. Remove and discard the old LCD display.
5. Place the new LCD display assembly over the mounting studs on the front panel and fasten it in place with the four standoffs. Make sure that the LCD display assembly is oriented with the cables pointing toward the left side (away from the keypad) of the meter.

Caution!

Do not overtighten the standoffs or the display assembly may be damaged.

6. Position the LCD display cables between the two mounting studs, and install the display shroud over the mounting studs. The top and bottom edges of the shroud are bent at a 90° angle to the main surface, and these edges must face inwards toward the display assembly.

Note: *One edge of the display shroud is covered with a piece of black electrical tape. This side of the shroud should be over the cables to protect them against abrasion.*

Rack Mount LCD Display Replacement (cont.)

7. Fasten the display shroud to the front panel with the four sets of nuts/washers.

Caution!

Do not overtighten the nuts or damage to the mounting threads may occur.

8. After checking for any loose hardware that may have fallen into the enclosure, reinstall the top panel on the meter and secure the panel in place with the four screws previously removed.

The Model GC868 flowmeter may now be placed back into service. Reconnect the main power and resume taking measurements.

Note: *Be sure to record the LCD Display replacement in Appendix A, Service Record.*

Rack Mount Printed Circuit Board Replacement

If troubleshooting procedures have indicated a defective printed circuit board, follow the instructions in this section to replace the defective board with a new one.

Circuit Board Removal

Refer to Figure B-2 on page B-11 and complete the following steps:

1. After disconnecting the main power to the meter, remove the top panel from the enclosure by removing the four screws indicated.

!WARNING!

The main power to the Model GC868 must be disconnected before proceeding.

2. Disconnect all external option card connectors at the rear panel of the meter. Then, remove all installed option cards from the printed circuit board, as described earlier in this chapter.
3. Disconnect the main POWER LEADS from the screw terminals at the rear of the printed circuit board. Make a sketch of the terminal block and the locations of the black, white and green power leads to assist in reinstallation of the new circuit board.
4. Remove the RS232, ANALOG OUT and TRANSDUCER connectors from the printed circuit board. Use a marker to identify pin #1 on the right side (keypad side) of these connectors.

Circuit Board Removal
(cont.)

Note: *These connectors should be pulled straight up and off the printed circuit board. DO NOT remove the leads from the screw terminals.*

5. Remove the flat KEYPAD CABLE connector from terminal J50 near the front of the printed circuit board. Mark pin #1 of the cable connector, which is located nearer the rear of the enclosure.
6. Disconnect the twisted-pair DISPLAY BACKLIGHT cable from connector J2 beneath the left side of the printed circuit board. Although this connector is polarized, it will help to note that the red wire is closer to the rear of the enclosure.
7. Remove the flat LCD DISPLAY CABLE connector from terminal J52 near the option card sockets. Mark pin #1 of the cable connector, which is located nearer the front of the enclosure.
8. Using a slotted screwdriver, remove the three mounting screws along each side of the printed circuit board. Carefully lift the printed circuit board out of the enclosure.

Proceed to the next section for instructions on installing the new printed circuit board.

Circuit Board Installation

Refer to Figure B-2 on page B-11 and complete the following steps:

1. Position the new printed circuit board within the electronics console so that it rests on the six standoffs in the base of the enclosure and the option card sockets are located near the rear of the enclosure. Secure the circuit board in place with the six screws previously removed.
2. Connect the flat LCD DISPLAY CABLE connector to terminal J52 near the option card sockets. Make sure the marked pin #1 side of the cable connector is located nearer the front of the enclosure.
3. Connect the twisted-pair DISPLAY BACKLIGHT cable to connector J2 beneath the left side of the printed circuit board. This connector is polarized and can only be installed with the red wire closer to the rear of the enclosure.
4. Connect the flat KEYPAD CABLE connector to terminal J50 near the front of the printed circuit board. Make sure the marked pin #1 side of the cable connector is located nearer the rear of the enclosure.

Circuit Board Installation
(cont.)

5. Install the RS232, ANALOG OUT and TRANSDUCER connectors onto the printed circuit board at the locations indicated in Figure B-2 on page B-11. Make sure the marked pin #1 sides of the connectors face the right side (keypad side) of the enclosure.

Note: *If any leads have come loose from the screw terminals on these connectors, refer to Appendix C, Optional Enclosures, of the Startup Guide for wiring instructions.*

6. Reconnect the main POWER LEADS to the screw terminals at the rear of the printed circuit board. When properly installed, the lead colors should be green, white and black, from left to right (as viewed from the front of the enclosure).
7. Reinstall all option cards, as described earlier in this chapter. Insert all external option card connectors at the rear panel of the meter.
8. After checking for any loose hardware that may have fallen into the enclosure, reinstall the top panel on the meter and secure the panel in place with the four screws previously removed.

The Model GC868 flowmeter may now be placed back into service. Reconnect the main power and refer to Chapter 2, *Initial Setup*, of the *Startup Guide* and Chapter 1, *Calibration*, of this *Service Manual* for instructions on properly setting up the meter for accurate flow rate measurements.

Note: *Be sure to record the printed circuit board replacement in Appendix A, Service Record.*

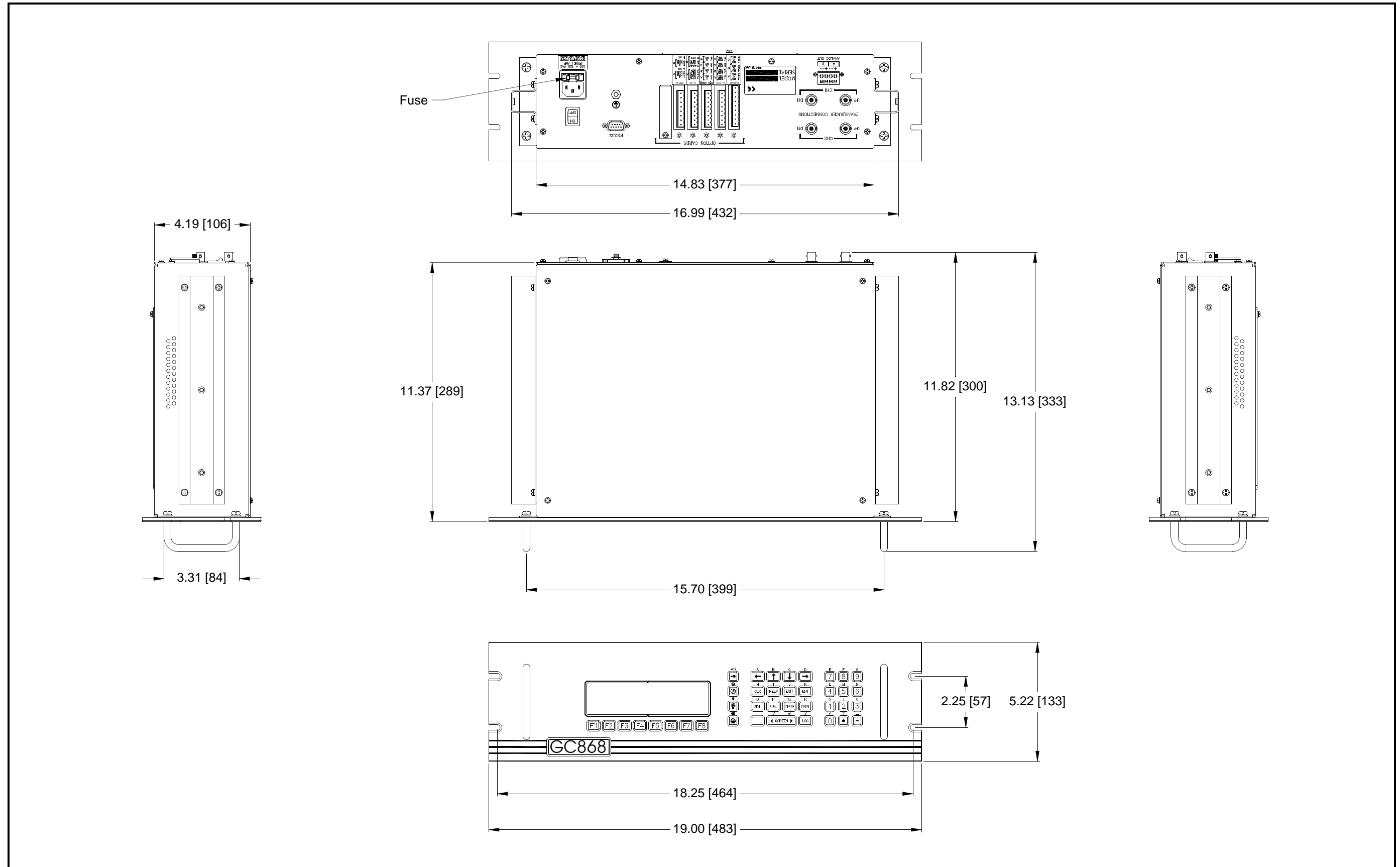

Figure B-1: Model GC868 Rock Mount Enclosure Dimensions - Drawing #712-1076

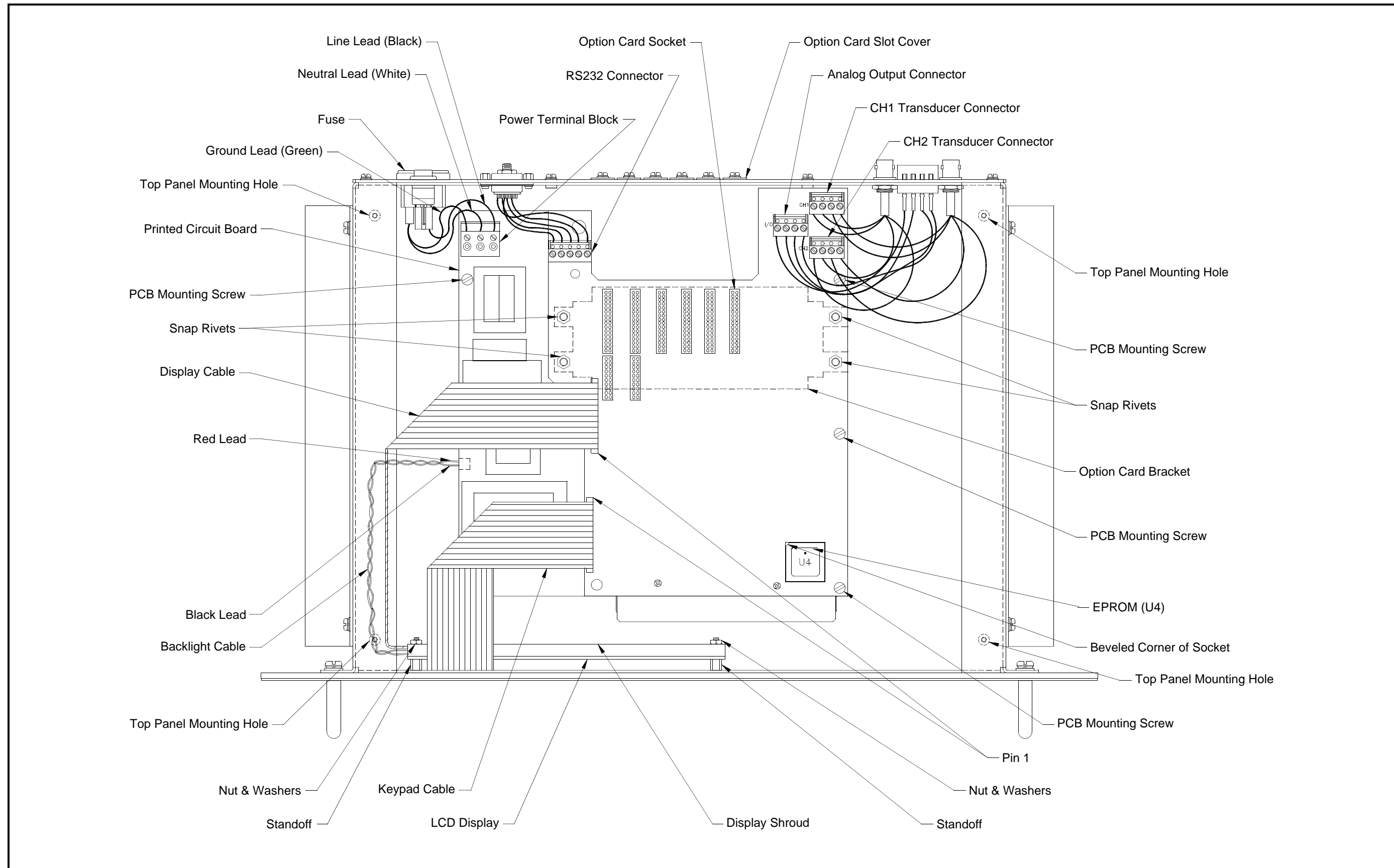

Figure B-2: Model G868 Rack Mount Console Assembly - Drawing #705-849

Index

A		D	
Acceleration Error - E6	2-3	Diagnostic Parameters	
Alarms Option Card, Testing	1-11	Table of Values	A-3
Amplitude Error - E5	2-3	Diagnostic Parameters, Table	3-2
Analog Inputs Option Card, Calibrating	1-6	Diagnostics Menu	
Analog Output Error - E7	2-3	Entering	3-1
Analog Outputs (Slot 0)		Exiting	3-4
As Calibrated Current Source	1-6	Display	
Calibrating	1-2	Cable	4-3
Linearity	1-2	LCD	4-6
Resolution	1-2	Replacing	4-6
Analog Outputs Option Card		Display Screen	
Calibrating	1-2	Error Message	2-1
Linearity	1-2	Illustration	2-1
Resolution	1-2		
B		E	
Bracket, Option Card	4-5	EPROM	
C		Replacing	4-4
Cable		User Program	4-4
Backlight	4-3, 4-8	Error Code	
Display	4-3, 4-6	E0	2-2
Keypad	4-3	E1	2-2
Calibrating		E15	2-4
See Parameter Name		E16	2-5
Calibration Menu, Entering	1-1	E2	2-2
Circuit Board		E3	2-2
See Printed Circuit Board		E4	2-3
Contamination, Gas	3-4	E5	2-3
Corrosion, Transducers	3-6	E6	2-3
		E7	2-3
		E8	2-3
		E9	2-4
		E10	2-4
		E11	2-4
		E12	2-4
		E13	2-4
		E14	2-4
		Error Message, Display Screen	2-1
		Expansion Slots	1-1

Index (cont.)

- | F | P |
|----------------------------------|-------------------------------------|
| Flowcell Problems | Pipe |
| Gas 3-4 | Measurements 3-5 |
| Pipe 3-5 | Problems 3-5 |
| Fuse | Pressure Input Error - E9 2-4 |
| Holder 4-2 | Printed Circuit Board |
| Rating 4-2 | EPROM 4-4 |
| Replacing 4-2 | Replacing 4-3 |
| Size 4-2 | PROBE Option |
| Type 4-2 | for RTD Option Card 1-9 |
| | Problems, Transducers 3-6 |
| G | R |
| Gas | Reboot, Automatic 1-1 |
| Contamination 3-4 | Replacing |
| Physical Requirements 3-4 | See Part Name |
| Problems 3-4 | RTD Option Card |
| Soundspeed 3-5 | Calibrating 1-9 |
| Grounding Strap 4-7 | |
| Guides, Option Card 4-5 | S |
| K | Screen Messages, Table 2-5 |
| Keypad, Cable 4-3 | Service Record A-1 |
| L | Shroud |
| LCD Display 4-6 | Aluminum 4-1, 4-8 |
| Leaks, Transducers 3-6 | LCD Display 4-6 |
| Low Signal Error - E1 2-2 | LVD 4-8 |
| LVD Statement 4-1 | Plastic 4-8 |
| N | Signal Quality Error - E4 2-3 |
| No Error - E0 2-2 | Sockets, Option Card 4-5 |
| Numer Option | Soundspeed |
| for RTD Option Card 1-10 | Error - E2 2-2 |
| | Gas 3-5 |
| O | Spare Parts List 4-9 |
| Option Card | Special Input Error - E10 2-4 |
| Analog Outputs 1-2 | |
| Bracket 4-5 | |
| Expansion Slots 1-1 | |
| Guides 4-5 | |
| Installing 4-5 | |
| Sockets 4-5 | |
| Over Range Error - E13 2-4 | |

Index (cont.)

T

Temperature Input Error - E8	2-3
Totalizer/Frequency Option Card, Testing . .	1-13
Totals Overflow Error - E14	2-4
Transducers	
Corrosion	3-6
Internal Damage	3-6
Leaks	3-6
Physical Damage	3-6
Placement	3-5
Problems	3-6

U

User Program	
EPROM	4-4
Upgrading	4-4

V

Velocity Range Error - E3	2-2
-------------------------------------	-----

We,

Panametrics Limited
Shannon Industrial Estate
Shannon, County Clare
Ireland

declare under our sole responsibility that the

GC868 Gas Clamp-On Ultrasonic Flowmeter

to which this declaration relates, are in conformity with the following standards:

- EN 61326:1998, Class A, Annex A, Continuous Unmonitored Operation
- EN 61010-1:1993 + A2:1995, Overvoltage Category II, Pollution Degree 2

following the provisions of the 89/336/EEC EMC Directive and the 73/23/EEC Low Voltage Directive.

Shannon - June 1, 2002

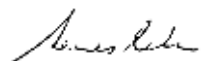

Mr. James Gibson
GENERAL MANAGER



CERT-DOC-H0



August 2004

Nous,

Panametrics Limited
Shannon Industrial Estate
Shannon, County Clare
Ireland

déclarons sous notre propre responsabilité que les

GC868 Gas Clamp-On Ultrasonic Flowmeter

relatif à cette déclaration, sont en conformité avec les documents suivants:

- EN 61326:1998, Class A, Annex A, Continuous Unmonitored Operation
- EN 61010-1:1993 + A2:1995, Overvoltage Category II, Pollution Degree 2

suivant les règles de la Directive de Compatibilité Electromagnétique 89/336/EEC et de la Directive Basse Tension 73/23/EEC.

Shannon - June 1, 2002

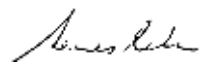

Mr. James Gibson
DIRECTEUR GÉNÉRAL



CERT-DOC-H0



August 2004

Wir,

Panametrics Limited
Shannon Industrial Estate
Shannon, County Clare
Ireland

erklären, in alleiniger Verantwortung, daß die Produkte

GC868 Gas Clamp-On Ultrasonic Flowmeter

folgende Normen erfüllen:

- EN 61326:1998, Class A, Annex A, Continuous Unmonitored Operation
- EN 61010-1:1993 + A2:1995, Overvoltage Category II, Pollution Degree 2

gemäß den Europäischen Richtlinien, Niederspannungsrichtlinie Nr.: 73/23/EG und EMV-Richtlinie Nr.: 89/336/EG

Shannon - June 1, 2002

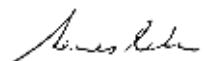

Mr. James Gibson
GENERALDIREKTOR



CERT-DOC-H0



August 2004



USA

1100 Technology Park Drive
Billerica, MA 01821-4111
Web: www.gesensing.com

Ireland

Shannon Industrial Estate
Shannon, County Clare
Ireland

