

Overview



SITRANS FUE950 is a universal thermal energy calculator, which meets the requirements EN 1434 and has the MID and PTB K7.2 approval for energy metering with the media water.

SITRANS FUE950 has been developed for the SITRANS FUS380/FUE380 and alternatively MAG 5000/6000 or FST020. SITRANS FUE950 is modular in construction and can by order be fitted with optional modules depending on the application. The FUE950 supports none of the SITRANS FX, FC products and only some of the FUS clamp-on products.

Benefits

Basic functions

- Prepared for heating, cooling measurement
- Approval for MID for heat metering and PTB K7.2 for cooling
- High-accuracy thermal energy metering, meets EN1434 requirements
- Measured temperature range -20 ... +190 °C (-4 ... +374 °F)
- Instantaneous values for energy/volume flow
- Battery or mains powered
- Battery version with battery lifetime of typical 10 years
- Optical data interface
- Real date and time
- Auto-detection of 2-wire or 4-wire temperature sensors

Additional functions

- Individual tariff functions
- Advanced functions for cooling/heating applications or the combination
- Memory for 24 periods (months, weeks, days)
- Data logger function
- Expandable functionality with 2 optional plug and play add-on modules
- Communication over M-Bus, RS485 or RS232

Add-on modules

- Plug-in module with 2 extra pulse inputs
- Plug-in module with 2 pulse outputs
- Plug-in module with combination of input and output pulses
- Plug-in module for M-Bus communication
- Plug-in module for RS232 or RS485 communication
- Plug-in module with 2 passive current outputs (4 ... 20 mA)

Application

The SITRANS FUE950 is able to handle 3 kinds of applications, means energy calculation in:

- District heating applications
- Chilled water applications
- Combined cooling/heating applications

Energy metering in heating, hot water applications (code "A" and "B")

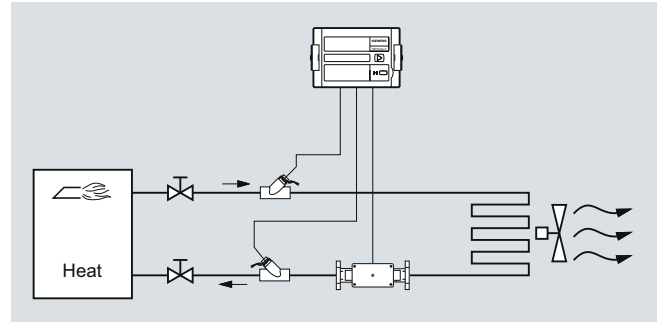

Energy metering in cooling, chilled water applications (code "C" and "D")

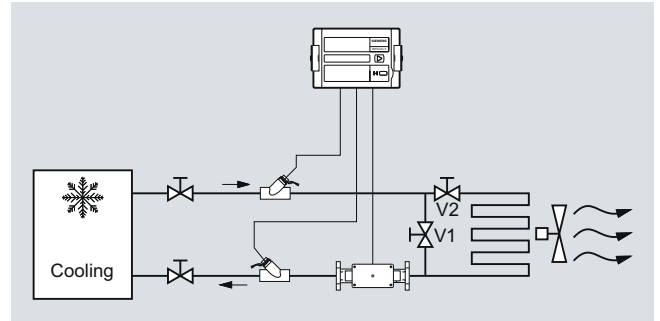

Energy metering in combined cooling/heating applications (code "E" and "F")

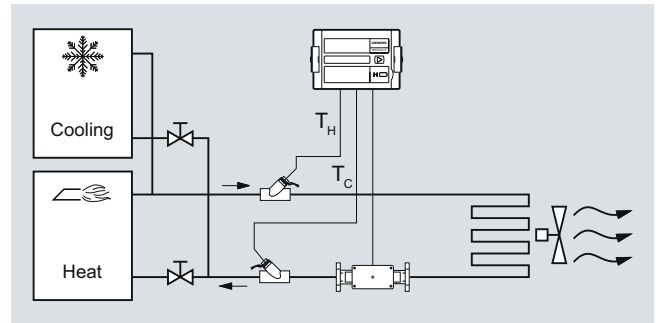

Flow Measurement

SITRANS F US Inline

SITRANS FUE950 energy calculator

Design

SITRANS FUE950 has an easy-read 8-digit LCD display with associated pictograms for the various functions. As the display has been made for several applications, there will be figures/symbols which are not used for normal district heating applications.

SITRANS FUE950 has a SIMPLE OPERATION push button and provides user-friendly control of various the display menu loops. The display will always be configured for the application chosen, and for the selected display settings.

The integrator has an IP54 plastic housing and is designed for wall or panel mounting. The housing comes with prepared rubber gaskets cable entries for fast and easy installation.

Operation menu loop structure

The FUE950 display has six menu loops and the menus are numbered in the display from 1 to 6. Some display menus consist of two values (to maximum seven) that are shown alternately at 4-second intervals.

The main menu loop no. 1 with the current data, e.g. for energy, volume, flow rate and temperature, is programmed as default setting.

In the combined heating/cooling configuration the menu loop no. 5 (tariff menu loop) will be activated additionally.

Display and output pulses

Units: MWh, GJ, Gcal, MBtu, m³, gal, m³/h, GPM, °C, °F and kW; all decimal points are statically (the unit "gal" is shown with factor x 100).

The display unit and the last fractional digit are typical used for the pulse outputs.

Function

Technical principle

Calculation of energy is based on the following formula:

$$\text{Energy} = \text{Volume} \times (T_{\text{Hot}} - T_{\text{Cold}}) \times K_{\text{factor}} (T_i)$$

Volume: Volume [m³] of a given amount of volume pulses

T_{Hot}: Measured temperature in the hot line

T_{Cold}: Measured temperature in the cold line

K_{factor} (T_i): Thermal coefficient of media enthalpy and heat content

The energy calculation is made by a counter and depends on temperature difference, pulse input frequency and legal requirements.

The calculator always carries out at least one energy calculation every 2 seconds. If the connected flowmeter has not sent enough pulses the energy calculation and flow indication is also based on the 8 seconds value.

Data memory

The FUE950 has a history memory of 24 periods (months, weeks, days). The following values are stored monthly, weekly or daily in the EEPROM on the programmed day of 1...31 (via software tool).

•Date/Time	•Volume
•Energy	•Error day counter
•Tariff energy 1	•Maximum monthly flow rate
•Tariff energy 2	•Maximum monthly power
•Tariff definition 1	•Date of maximum monthly flow rate
•Tariff definition 2	•Date of maximum monthly power
•Pulse counter input 1	•Pulse counter input 2
•Operation hours	

Data logger memory (LOG)

The LOG of the calculator is stored every 24 hours with all cumulative values in the EEPROM. The storage frequency can be selected from various storage intervals (5, 6, 10, 12, 15, 20, 30, 60 minutes or the default setting of 24 hours). The data which are stored in the LOG could be read out using a software tool and can be used for evaluations.

Extract of possible LOG settings

Storage interval	Values	Number of data records	Recording period
5 minutes	• Error status	440	36.6 hours
15 minutes	• Overload time temperature	440	110 hours
1 hour	• Overload time flow rate	440	18.3 days
24 hours (default setting)	• Forward temperature • Return temperature • Date and time • Energy • Tariff energy 1 • Tariff energy 2 • Tariff definition 1 • Tariff definition 2 • Volume • Error day counter	440	440 days

Maximal Values

The integrator creates max. values for power and flow rate based on consumption time, which are stored in the EEPROM. The integration intervals are adjustable to 6, 15, 30 or 60 minutes and 24h. Default setting is 60 minutes.

Tariff/Accounting date function

The calculator includes two independent memories in which the accumulated energy at two programmable tariff dates are stored.

- Last accounting date
- Last but one accounting date

Values stored

- Energy
- Volume
- Tariff counter 1
- Tariff counter 2
- Pulse counter 1
- Pulse counter 2
- Date

The integrator offers two optional tariff memories for monitoring plant load states. Here it concerns threshold value tariffs. Extensive tariff conditions make it possible to adapt the calculator individually to the required customer-specific applications.

Both tariffs are separately configurable and independent from each other. Energy or time can be measured alternatively per tariff register dependent on the tariff mode adjusted in each case.

With the "time triggered tariff function" the switch-on time and the switch-off time are adjustable independent from each other for each day of the week in steps of 15 minutes.

The following limit types of the tariff function are possible: (This example applies to the display at 1 fractional digits after comma)

Type	Description	Limit	Limit resolution
dT	Temperature difference	1 ... 190 °C	1 °C
-dT	Negative temperature difference	1 ... 190 °C	1 °C
TR	Return temperature (low)	1 ... 190 °C	1 °C
TV	Forward temperature (high)	1 ... 190 °C	1 °C
P	Power	10 ... 2 500 kW	10 kW
Q	Flow	1 ... 255 m ³ /h	1 m ³ /h
FE	"Theoretically forward energy" with return temperature of 0 °C		
Z	"Time triggered" counting energy		
E	"External" counting energy		

Error handling and memory

Events such as changes and faults are stored in a non-volatile memory with a capacity of up to 127 entries. The following events are recorded:

- Checksum error
- Temperature measurement error
- Error hours
- Start and end of test mode

If SITRANS FUE950 records an error, this will be automatically indicated by a "alarm symbol" on the display.

To protect the reading data, all the relevant data are saved in a non-volatile memory (EEPROM). This memory saves the measured values, device parameters and types of error at regular intervals.

The following events are recorded:

- Temperature sensor error
- Swapped hot and cold temperature sensors
- Battery low warning
- Power supply failure
- Optical communication warning
- RAM checksum error

Outputs/Inputs/Communication

Communication interfaces:

SITRANS FUE950 is fitted with an optical infra-red send/receive port in accordance with EN1434/IEC 61107, protocol standard, EN1434/EN 60870-3 (M-Bus protocol).

A reader head with a permanent magnet (IrDA-adaptor) in accordance with EN 1434 can be used for readout data or communication with the parameterization software.

2 ports for optionally plug-in modules

The calculator features 2 ports for the plug-in modules.

One slot is for the function modules and the other for the communication modules.

Communication modules

The following communication modules are available as options: RS232 module, RS485 module and M-Bus module. The RS232 and RS485 communication modules are serial interfaces and permit data exchange with the calculator. For this purpose a special data cable is necessary.

The M-Bus module is a serial interface for communication with external devices (M-Bus Master/Centre). According to the M-Bus structure a number of calculators can be connected to a control centre.

Pulse input module

Two pulse inputs are available. The pulse value and the unit is configurable for energy, water, gas or electrical meter by parameterization software. Data are separate cumulated in different registers and are also stored on the two accounting day's (Tariff registers).

Combined Pulse Input/Output module

Two pulse inputs combined with one pulse output are available on one module. The pulse inputs are configurable with value and the unit by parameterization software.

The pulse output is also programmable using the parameterization software.

Pulse output

The calculator provides levels for two optional external pulse outputs, which can be freely programmed using the parameterization software tool.

Default setting is one pulse occurs per change in the least significant digit in the display with the unit and resolution selected by the device ordering.

Possible pulse output values

- Energy (default setting)
- Volume (default setting)
- Tariff energy 1
- Tariff energy 2
- Tariff condition 1, limit switch
- Tariff condition 2, limit switch
- Energy error
- Volume error
- Volume with specific resolution (0.1, 1.0, 10 or 100)
- Energy with specific resolution (0.1, 1.0, 10 or 100)

Combined current output module

Optional module with 2 passive 4 ... 20 mA outputs.

Possible output values:

- Power (default setting for output #1)
- Flow (default setting for output #2)
- Hot, cold or difference temperature

The settings can be configured by parameterization software. The current output module occupies both ports, means no other plug-in module will possible to plug in.

Module combinations

The calculator has a group of extension modules for communication and another group of extension modules for additional functionality. These modules are available first selected within the calculator, or for retrofitting in the field.

One single function module as well as one single communication module out of following modules is selectable.

Function modules:

- Pulse input module, 2 inputs
- Pulse output module, 2 outputs
- Combined pulse module 2 inputs, 1 output
- Combined current output module, 2 x passive 4 ... 20 mA (occupies both ports)

Communication modules:

- M-Bus (M-Bus protocol according EN 1434-3)
- RS232 (M-Bus protocol according EN 1434-3)
- RS485 (M-Bus protocol according EN 1434-3)

Flow Measurement

SITRANS F US Inline

SITRANS FUE950 energy calculator

Integration

SITRANS FUE950 is a multi-purpose energy calculator for media water which meets the requirements of EN 1434. Further, the energy calculator has been specially developed to work with the volume pulses from SITRANS FUS380/FUE380 or alternatively MAG 5000/6000 or FST020 transmitter.

Technical specifications

Approval	MID approved in accordance with energy meter EN 1434 and PTB K7.2 (German national cooling approval)	
Approved temperature range	<ul style="list-style-type: none"> • Heating 0 ... 180 °C (32 ... 356 °F) • Cooling 0 ... 105 °C (32 ... 221 °F) 	
Absolute temperature range	-20 ... +190 °C (-4 ... -374 °F)	
Differential temperature	<ul style="list-style-type: none"> • Heating 3 ... 177 K (starting at 0.1 K) • Cooling 3 ... 102 K 	
Measuring accuracy	Meets requirements of EN1434 Typically max. $\pm (0.5 + 3K/\Delta\Theta)$ [%] of measured value	
Flow range	Depends on pulse input value (I/N0), see "Selection and Ordering data".	
Power range value	Depends on pulse input value as follow:	
	Pulse input value (I/P or gal/P)	Max power [kW]
	1	15 000
	2.5	15 000
	5	15 000
	10	150 000
	25	150 000
	50	150 000
	100	1 500 000
	250 *)	1 500 000
	500 *)	1 500 000
	1 000 *)	15 000 000
	*) not available for gal/pulse	

Typical accuracy of FUE950

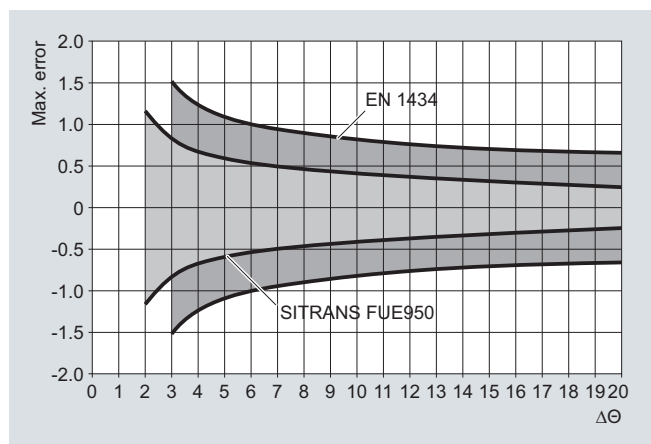

User interface (always included)

Display	8-digit LCD display with associated pictograms/symbols
Units	MWh, GJ, Gcal, MBtu, m ³ , m ³ /h, GPM, gal, °C, °F, kW (gal is shown with factor x 100)
Totalizer value range	99 999 999 or 9 999 999.9 (0 and 1 digit after comma). Display digits: Flow in 6 digits; Volume, power and energy in 8 digits
Values	Power, energy, volume, flow rate, temperatures
Push button	Single push button for the menu controlling
Optical interface IrDA interface	ZVEI optical interface with M-Bus protocol as per EN1434, connection via separate IrDA-adaptor Baud rate: 300 or 2400

Rated operation conditions

Enclosure	IP54 in accordance with IEC 529
Material	
• Housing	C Lexan 141R (or similar); colors: light gray (top part) and black (bottom part)
• Pipe/wall fitting	PA 6,6 GF25 (or similar)
• Other plastic parts	ABS Cycolac GPM500 (or similar)
• Gaskets	Neoprene and rubber cable bushings: EPDM 50
• Rubber cable bushings	EPDM 50
Temperature	
• Ambient	0 ... 55 °C (32 ... 131 °F)
• Storage	-25 ... +70 °C (-13 ... +158 °F)
Environment class	
• Mechanic class	M1
• Electromagnetic class	E1 (MID) or C (DIN EN 1434)

Temperature input (always included)

Function	The temperature sensors must be connected to terminals 1-5 and 6-2 (TH) and 3-7 and 8-4 (TC) depending on cable type (2-wire or 4-wire).
Temperature range Absolute measuring range	-20 ... 190 °C (-4 ... 374 °F) for T _H and T _C
Temperature difference	Start 0.1 K, min. 3 K, max. 177 K
Measurement resolution	0.125 K
Display resolution	T _H and T _C : 1 K ΔT: 0.1 K
Sensor types	Pt100 or Pt500 as 2-wire or 4-wire; Standard is Pt500. Sensor cable length: up to 10 m (according EN 1434 and MID-type approval).
Sensor connection	4-wire or 2-wire; auto detection of connection version

Flow input (In 0) (always included)

Function	Used as standard for flow input of the external flowmeter. The input is marked as 10 (+ Flow Pulse), 11 (- Gnd) on the terminal strip. Note: The pulse input value selection must be the same as the pulse output setting of the flowmeter.
----------	--

Flow Measurement

SITRANS F US Inline

SITRANS FUE950 energy calculator

Pulse value	1 ... 1 000 l/pulse or 1 ... 100 gal/pulse, selection by order code. Will be shown at the device label
Pulse frequency	≤ 100 Hz (200 Hz)
Pulse ON-time	≥ 3 ms
Pulse OFF-time	≥ 2 ms
Type	Active pulse input
Terminal voltage	3.6 V DC (supplied internally by FUE950)
Flowmeter installation place	The flowmeter installation place can be in the hot line or cold line ("forward or return pipe") selected by order code. The "installation place" will be shown at the device display and nameplate
Connected cable	Max. 10 m (shielded cables recommended)
Ports for option modules	
Type	The calculator features 2 ports for optional plug-in modules. Port 2 for one of the function modules and port 1 for one of the communication modules.
Function modules (Port 2)	<ul style="list-style-type: none"> • Pulse input module, 2 inputs (In1, In2) • Pulse output module, 2 outputs (Out1, Out2) • Combination module of 2 inputs (In1, In2) and 1 output (Out1)
Current output module (Port 1)	2 passive 4 ... 20 mA (#1, #2) (occupies both port 1 and 2)
Communication modules (Port 1)	M-Bus, RS 232 or RS 485 (M-Bus protocol, according EN 1434-3)
Pulse output (Optional module on port 2)	
Function	The module contains connections for 2 pulse outputs, which can be programmed as desired using a software tool. The pulse outputs are marked as standard as O1, 'gnd' and O2, 'gnd' on the terminal strip and Out1 respectively Out2 in the display.
Type	Passive "open collector" pulse output, outputs potential isolated to each other
Pulse value	Last significant digits of the display (unit/pulse), selection by order code and setting can be read via display menu, settings changeable via software tool
Pulse output 1	
• Pulse frequency	≤ 4 Hz
• Pulse width	100 ... 150 ms
• Pulse duration	125 ms ± 10 %
• Pulse break	125 ms ± 10 %
Pulse output 2	
• Pulse frequency	≤ 100 Hz, depending on the selected pulse length
• Ratio	Pulse duration/pulse break ~1:1
Pulse length	5, 10, 50, 100 ms (default: 5 ms)
External voltage supply	3 ... 30 V DC
Current	≤ 20 mA with a residual voltage of ≤ 0.5 V

Possible pulse output selection	<ul style="list-style-type: none"> • Energy (default setting for 'Out1') • Volume (default setting for 'Out2') • Tariff energy 1 • Tariff energy 2 • Tariff condition 1 (limit switch) • Tariff condition 2 (limit switch) • Energy error • Volume error • Volume with specific display resolution (or with factor 0,1, 10 or 100 thereof) • Energy with specific display resolution (or factor 0.1 thereof)
Pulse input (Optional module on port 2)	
Function	Add-on module for two additional counters. The pulse input 1 is marked as I1, 'gnd' and the input 2 as I2, 'gnd' on the terminal strip and indicated in the display as separate registers IN1 and IN2 and can also be transferred via the communication modules.
Type	Passive "open collector" pulse inputs, outputs not potential isolated to each other, data are separate cumulated in different registers and are also stored on the two accounting day's.
Pulse value	Pulse value and the unit are configurable for energy, water, gas or electrical meter by a software tool Default: Pulse input 0.1 m ³ or 1 gal (if unit 'gal' is ordered with the Z-option "L05")
Pulse frequency	≤ 8 Hz
Pulse length	≥ 10 ms
External voltage supply	3 V DC (supplied internally by FUE950)
Current	based on R _i = 2.2 MΩ
Cable length	< 10 m connection limit
Current output module (Optional on port 1 and 2, both ports are occupied)	
Function	The module contains connections for 2 passive current outputs, which can be programmed individually using the software tool. The outputs are marked „#1" and „#2" with corresponding polarity „+" and „-" on the terminal strip.
Terminal voltage	External supply: 10 ... 30 V DC (passive output)
Signal range	4 ... 20 mA; 4 mA = 0 value and 20 mA = default maximum values (for #1: Power in kW and for #2: Flow with the max. values and selected unit). Defaults: For power it is the max. selectable value x 100 000 the last digit of display (e. g. 20 mA = 10 000.0 kW (1 digit res.) or 100 000 kW (0 digit res). For flow it is the max. selectable value x 10 000 the last digit of display (e. g. 20 mA = 1 000.0 m ³ /h (1 digit res.) or 10 000 m ³ /h (0 digit res).)

Flow Measurement

SITRANS F US Inline

SITRANS FUE950 energy calculator

Load	Max. 800 Ω
Upper limit	Up to 20.5 mA (exceed causes the error current value)
Signal on alarm	Errors are indicated with 3.5 mA or 22.6 mA (programmable, default: 3.5 mA)
Output values	Power, flow, temperature (configuring via software tool; default: for #1: Power and for #2: Flow)
M-Bus output (Optional module on port 1)	
Type	The optional M-Bus plug-in module is a serial interface for communication with external devices (M-Bus Repeater)
Protocol	M-Bus according EN1434-3
Connection	The connection is not polarity-conscious and is electrically isolated, connection of 2 x max. 2.5 mm ² wires, 300 or 2400 baud (auto baud detection), current drawn: one M-Bus load. M-Bus address: Each port has its own primary M-Bus address. The secondary address is unique for each calculator and is factory-set to equal the serial number.
RS232 output (Optional module on port 1)	
Type	The optional module RS232 is a serial interface for data transmission with external devices, e.g. PC; Baud rate: 300 or 2400. The module contains a 3-pole terminal strip with terminals marked 62 (TX), 63 (RX) and 64 (GND). For this purpose a special data cable is necessary.
Protocol	M-Bus according EN1434-3
Connection	The module contains a 3-pole terminal strip with terminals marked 62, 63, 64 (max. 2.5 mm ²); Connected cable length: max 10 m; For communication with a PC a special adapter cable is required (order no. A5E02611774).
RS485 output (Optional on port 1)	
Function	The optional RS 485 module is a serial interface for data transmission with external devices, e.g. PC; Baud rate: 2400. The module contains a 4-pole terminal strip with terminals marked D+, D-, Vcc and GND.
Protocol	M-Bus protocol according EN 1434-3
Connection	Terminals D+ and D-; electrically isolated; 2400 baud only. An external supply of 12 V DC ± 5 V (<5 W) is needed for the module (terminals Vcc and GND). The module terminals are max. for 2.5 mm ² wires. Connected cable length: max. 10 m
Power consumption	
230 V and 24 V versions	Typical current appr. 0.15 VA
3.6 V D-cell battery	Typical battery lifetime 10 years under normal conditions (no add-on modules, max. 40 °C ambient temperature)

Supply data	Internal voltage 3.6 V by the battery or plug-in power supply module
Battery, 3.6 V type (option)	3.6 V lithium D-cell, battery lifetime typically 16 years with independently powered flowmeter
230 V AC module (option)	Plug-in module for 230 V AC (195 ... 253 V AC), 50/60 Hz (incl. battery backup)
24 V AC module (option)	Plug-in module for 24 V AC (12 ... 30 V AC) (incl. battery backup)
Battery backup (option)	Only with mains supply modules by internal 3.0 V lithium battery (type CR 2032) Displayed values, date and time are still updated, but the measuring functions have stopped, including the flow rate measurement. Communication via optional modules M-Bus, RS485, RS232 or optical interface is maintained, affecting the backup battery lifetime.

Accessories/Software

The parameterization software based on the M-Bus is a convenient tool for handling the calculator. It runs on Windows® and is used for:

- Configuration of the calculator functionality, reading out different memories, printing out calculator logs (standard).
- Expert programming of the device (advanced setup).
- Lap test programming of the device (full setup)

Configuration of the calculator functionality, reading out different memories, printing out calculator logs. For further details please contact your local Siemens representative.

A reader head with a permanent magnet in (IrDA adapter with bluetooth) accordance with EN 1434 can be used for programming/altering programming of readout data, configuration data, etc. The reader head can also be used to change measuring data.

Dimensional drawings

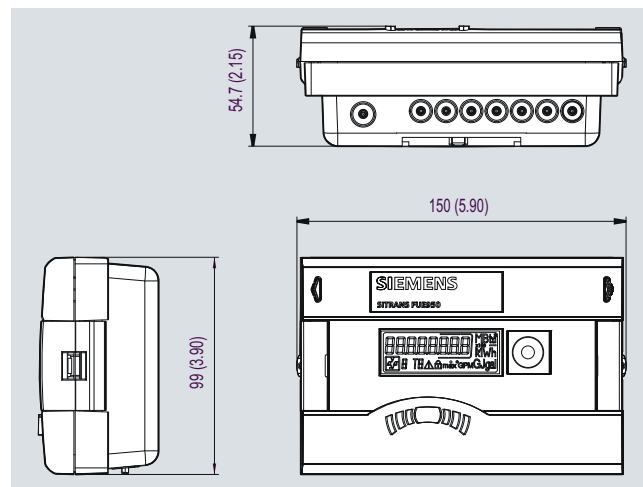

SITRANS FUE950, dimensions in mm (inch)

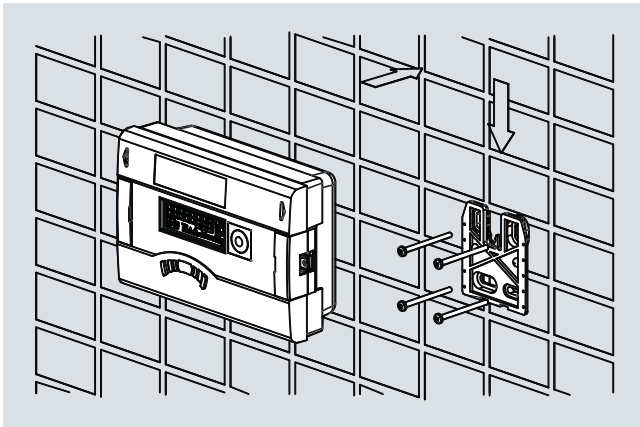

Wall mounting

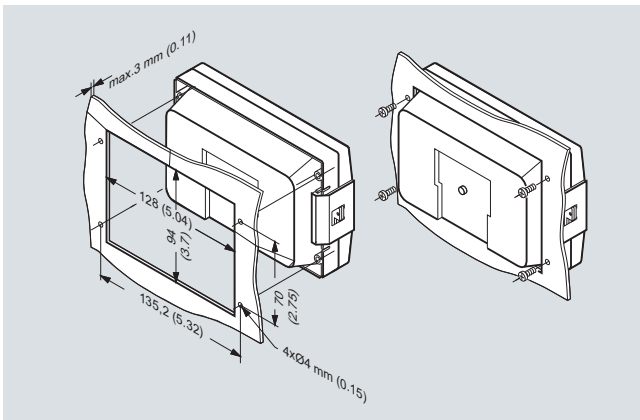

Panel mounting, dimensions in mm (inch)

Pt500 temperature sensor pairs

Application

The temperature sensor set is designed for use with the Siemens energy calculator type SITRANS FUE950 for measurement of the energy consumption in a district heating or cooling net.

Temperature sensors are one of the integral components of every thermal energy meter in heating or cooling applications. They are used for determining temperature changes in fluids due to energy taken from or supplied to the loop. The temperature is thus measured by mounting temperature sensors upstream and downstream from the point where the exchange in the thermal energy of the system is.

To ensure an accurate measurement of the temperature difference according to MID (EN 1434) or PTB K7.2 the sensors are delivered as matched pairs.

By selection with the order code the Pt500 sensor pair sets can be delivered with heating approval or with approvals for combined heating/cooling applications.

Technical specifications

Temperature sensor pairs:

2-wire Pt500

Pt500 2-wire temperature sensor pair (EN 1434)	
Measuring insert	Pt500 temperature sensor, EN 60751, tolerance class B, 2-wire
Pairing	Paired to EN1434 (10 ... 130 °C/14 ... 266 °F)
Media temperature	0...150 °C (32 ... 302 °F)
Response time $T_{0,5}$	See sensor pocket specifications
Medium	Typically heating water
Pressure rating	See sensor pocket specifications
Protection	IP65
Pipe material	AISI 304Ti/1.4303
Dimension	Ø 6 mm
Sensor tube length	50 mm
Cable length	2, 3, 5 or 10 m (6.56, 9.84, 16.4 or 32.8 ft), fixed connected

4-wire Pt500

Pt500 4-wire temperature sensor pair (with MID and PTB K7.2 approval)	
Measuring insert	Pt500 temperature sensor, EN 60751, tolerance class to ISO 751 Class B; 4-wire
Pairing	Matched paired according to EN 1434 at 10, 75 and 140 °C (50, 167 and 284 °F)
Type approval	MID (DE-06-MI004-PTB011) and PTB K7.2 (PTB 22.77/09.01). Only to be mounted with related sensor pockets according to the type approvals.
Media temperature	0...150 °C (32 ... 302 °F)
Permissible temp. pair range for ΔT	<ul style="list-style-type: none"> • Heating 3 ... 150 K • Cooling 3 ... 85 K
Medium	Approved for heating/cooling water
Protection	IP65
Environment	<ul style="list-style-type: none"> • Mechanic class M3 • Electromagnetic class E1 (MID)
Pressure rating	See sensor pocket specifications
Material	<ul style="list-style-type: none"> • Protective tube Stainless steel AISI 304Ti/1.4571 (or similar), diameter of protective tube: 6 mm • Connector cable Silicon, connection wire terminals Terminal sleeves to DIN 46228
Sensor tube length	140 or 230 mm (5.51 or 9.06 inch)
Cable length	5 m (16.4 ft), fixed connected

Flow Measurement

SITRANS F US Inline

SITRANS FUE950 energy calculator

Sensor pockets

Stainless steel sensor pocket (for 4-wire Pt500 types only)

Media temperature	0 ... 150 °C (32 ... 302 °F)
Approval	Approved only together with 4-wire sensors
Medium	Approved for heating/cooling water; up to max. 5 m/s flow velocity
Pressure rating	PN 40
Length	Face-to-face length 120/135 and 210/225 mm (4.72"/5.23" and 8.27"/8.86")
External diameter	Protective tube 8/11 mm (0.32"/0.43")
Internal diameter	Protective tube 6 mm (0.24")
Pipe connection	Thread G 1/2" (with sealing screw for sensor)
Material	Protective tube AISI 316Ti/1.4571 (or similar)
Use	<ul style="list-style-type: none"> Use with related 4-wire Pt500 sensors only (according to type approval) For flow velocities up to 5 m/s Recommended to install with welded sleeve (according to EU standard)

Stainless steel sensor pocket (for 2-wire Pt500 types only)

Media temperature	0 ... 180 °C (32 ... 356 °F)										
Medium	Approved for heating water										
Response time $T_{0.5}$	Typically 13 s at 0.4 m/s with pasta Typically 5 s at 0.4 m/s without pasta										
Pressure rating	PN 25										
Length	<table border="1"> <tr> <td>L1 (mm)</td> <td>92</td> <td>127</td> <td>168</td> <td>223</td> </tr> <tr> <td>L (mm)</td> <td>82</td> <td>117</td> <td>155</td> <td>210</td> </tr> </table>	L1 (mm)	92	127	168	223	L (mm)	82	117	155	210
L1 (mm)	92	127	168	223							
L (mm)	82	117	155	210							
Material	Stainless steel: AISI 316Ti/1.4571										
Use	For 2-wire Pt500 types only										

Brass sensor pocket (for 2-wire Pt500 types only)

Media temperature	0 ... 150 °C (32 ... 302 °F)								
Medium	Approved for heating water								
Response time $T_{0.5}$	Typically 9 s at 0.4 m/s with pasta Typically 5 s at 0.4 m/s without pasta								
Pressure rating	PN 16								
Length	<table border="1"> <tr> <td>L1 (mm)</td> <td>47</td> <td>92</td> <td>127</td> </tr> <tr> <td>L (mm)</td> <td>40</td> <td>82</td> <td>117</td> </tr> </table>	L1 (mm)	47	92	127	L (mm)	40	82	117
L1 (mm)	47	92	127						
L (mm)	40	82	117						
Material	Brass: CuZn ₄₀ Pb ₂ (Ms58)								
Use	For 2-wire Pt500 types only								

Dimensional drawings

Pt500 2-wire temperature sensor pair (EN 1434)

Cable length 2, 3, 5 or 10 m ('C' at the dimensional drawing)

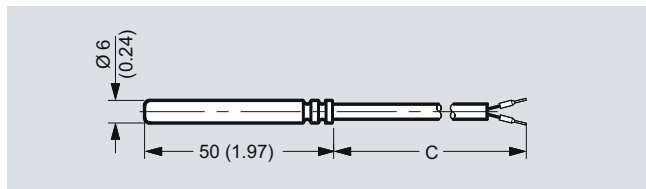

Pt 500 2-wire temperature sensor, dimensions in mm (inch)

Pt500 4-wire temperature sensor pair (with MID and PTB K7.2 approval)

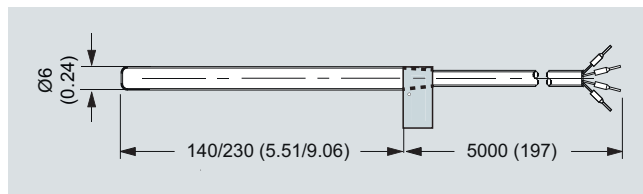

Pt500 4-wire temperature sensor, dimensions in mm (inch)

Stainless steel sensor pocket (for 2-wire Pt500 types only)

Length	L1 (mm)	92	127	168	223
	L (mm)	82	117	155	210

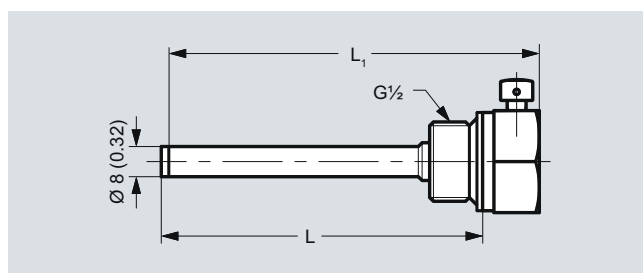

Sensor pocket (for 2-wire Pt500 types only), stainless steel, dimensions in mm (inch)

Stainless steel sensor pocket (for 4-wire Pt500 types only)

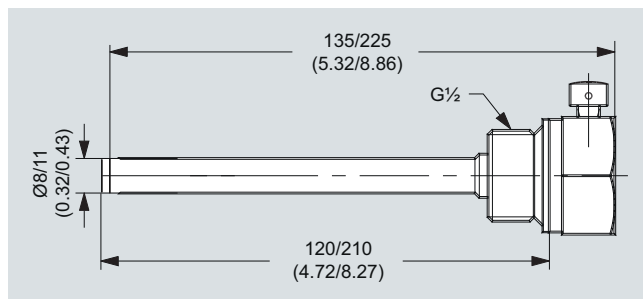

Stainless steel sensor pocket, dimensions in mm (inch)

Brass sensor pocket (for 2-wire Pt500 types only)

Length	L1 (mm)	47	92	127
	L (mm)	40	82	117

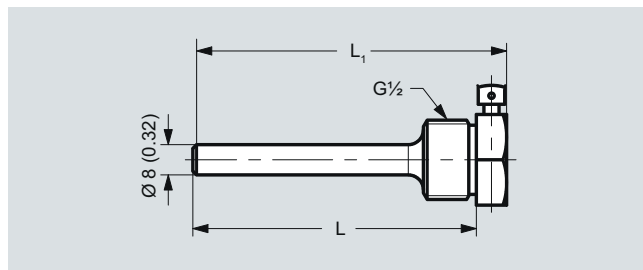

Sensor pocket, brass (for 2-wire Pt500 types only), dimensions in mm (inch)

Selection and Ordering data				Order No.	Order code
Energy calculator SITRANS FUE950, MID or PTB K7.2 custody transfer approved				7ME3480-	-
Flow input setting (In 0) (The pulse input value selection must be the same as the pulse output setting of the selected flowmeter)					
Pulse input in l/pulse or in gal/pulse (with option L05)	Flow limit Q_{max} in m³/h	Flow limit Q_{max} in GPM *) (with option L05)			
1	360	6 000	(In l/p recommended selection for MAG: DN 2 ... 65 and FUS380/FUE380: DN 50 ... 65)	2 A	
2.5	900	15 000	(In l/p recommended selection for MAG and FUS380/FUE380: DN 80 ... 125)	2 B	
5	1 800	30 000		2 C	
10	3 600	60 000	(In l/p recommended selection for MAG and FUS380/FUE380: DN 150 ... 250)	3 A	
25	9 000	150 000		3 B	
50	18 000	300 000	(In l/p recommended selection for MAG and FUS380/FUE380: DN 300 ... 400)	3 C	
100	36 000	600 000	(In l/p recommended selection for MAG and FUS380/FUE380: DN 500 ... 1200)	4 A	
250	90 000	-	(In gal/pulse and GPM not available)	4 B	
500	180 000	-	(In gal/pulse and GPM not available)	4 C	
1 000	360 000	-	(In gal/pulse and GPM not available)	5 A	
*) GPM = Gallons per minute					
Calculator application/Flowmeter installation place					
For heating, flowmeter in return pipe (cold pipe), typical standard				A	
For heating, flowmeter in forward pipe (hot pipe)				B	
For cooling, media water, flowmeter in forward pipe (cold pipe)				C	
For cooling, media water, flowmeter in return pipe (hot pipe)				D	
For combined cooling/heating, flowmeter in forward pipe (hot pipe as heating) (MID conformity declaration for heating)				E	
For combined cooling/heating, flowmeter in return pipe (cold pipe as heating) (MID conformity declaration for heating)				F	
Temperature sensor type					
Pt500 setup, no sensor pair included (standard)				0	
Pt500 setup and Pt500 sensor pair (6/140 mm), 4-wire with 5 m connection cable, 6 mm sensor diameter and 140 mm sensor length. MID approved DE-06-MI004-PTB011, PTB approved 22.77/09.01 (mentioned approvals are only valid if temp. sensors are used with the applicable temperature sensor pockets).				3	
Pt500 setup and Pt500 sensor pair (6/230 mm), 4-wire with 5 m connection cable, 6 mm sensor diameter and 230 mm sensor length. MID approved DE-06-MI004-PTB011, PTB approved 22.77/09.01 (mentioned approvals are only valid if temp. sensors are used with the applicable temperature sensor pockets).				4	
Pt100 setup, no sensor pair included				5	
Temperature sensor pocket sets: (for 6 mm sensor diameter)					
No pockets (standard)				0	
Stainless steel pocket, 120/135 mm length for 6 mm sensor diameter, max. PN 40 and max. 5 m/s (2 pcs. for 140 mm 4-wire sensors above)				5	
Stainless steel pocket, 210/225 mm length for 6 mm sensor diameter, max. PN 40 and max 5 m/s (2 pcs. for 230 mm 4-wire sensors above)				7	
Voltage supply					
Battery 3.6 V DC (Lithium D-cell type) (standard)				1	
Mains power module for 230 V AC supply (incl. back-up battery)				2	
Mains power module for 24 V AC supply (incl. back-up battery)				3	
No power supply module (power supply ordering separate)				4	

Flow Measurement

SITRANS F US Inline

SITRANS FUE950 energy calculator

Selection and Ordering data	Order No.	Order code
Energy calculator SITRANS FUE950, MID or PTB K7.2 custody transfer approved	7ME3480 -	
Option modules at place 1 and 2		
No module at port 1 and 2 (standard)		A
<u>Module on port 1 (communication)</u>		
M-Bus module and no module on port 2		B
RS232 module (M-Bus protocol) and no module on port 2		C
RS485 module (M-Bus protocol) and no module on port 2		D
<u>Module on port 2 (pulse in-/outputs)</u>		
Pulse output, 2x output (Out1 "Energy" and Out2 "Volume") and no module on port 1		E
Pulse input, 2x input (In1 and In2) and no module on port 1		F
Pulse out-/input combination, 2x input and 1x output and no module on port 1		G
<u>Combination of modules on port 1 and 2</u>		
M-Bus module (port 1) and Pulse output, 2x output (Out1 "Energy" and Out2 "Volume") (port 2)		H
M-Bus module (port 1) and Pulse input, 2x input (In1 and In2) (port 2)		J
M-Bus module (port 1) and Pulse out-/input combination, 2x input and 1x output (port 2)		K
RS232 module (M-Bus) (port 1) and Pulse output, 2x output (Out1 "Energy" and Out2 "Volume") (port 2)		L
RS232 module (M-Bus) (port 1) and Pulse input, 2x input (In1 and In2) (port 2)		M
RS232 module (M-Bus) (port 1) and Pulse out-/input combination, 2x input and 1x output (port 2)		N
RS485 module (M-Bus) (port 1) and Pulse output, 2x output (Out1 "Energy" and Out2 "Volume") (port 2)		P
RS485 module (M-Bus) (port 1) and Pulse input, 2x input (In1 and In2) (port 2)		Q
RS485 module (M-Bus) (port 1) and Pulse out-/input combination, 2x input and 1x output (port 2)		R
Combinations current output module, 2x passive 4 ... 20 mA (Out 1 "Power", Out 2 "Flow") (occupies module port 1 and 2)		S
Display units and resolutions		
MWh & kW, m ³ , m ³ /h in 1 digit resolution; Temperature: no decimal figures		D
MWh & kW, m ³ , m ³ /h in 0 digit resolution; Temperature: no decimal figures		E
GJ & kW, m ³ , m ³ /h in 1 digit resolution; Temperature: no decimal figures		J
GJ & kW, m ³ , m ³ /h in 0 digit resolution; Temperature: no decimal figures		K
Gcal & kW, m ³ , m ³ /h in 1 digit resolution; Temperature: no decimal figures		N
Gcal & kW, m ³ , m ³ /h - in 0 digit resolution; Temperature: no decimal figures		P
Mbtu & kW, m ³ , m ³ /h in 1 digit resolution; Temperature: no decimal figures		R
Mbtu & kW, m ³ , m ³ /h - in 0 digit resolution; Temperature: no decimal figures		S
Verification/Approval		
Without type approval mark, neutral label (standard))		0
With MID type approval mark (only for heating combinations, selection "A, B, E and F")		1
With MID approval mark and first verification (only for heating, selection A, B, E and F")		2
Cooling approval mark, German national cooling approval according PTB-TR-K7.2 (only for cooling and media water, selection "C and D")		7
Cooling approval mark, German national cooling approval according PTB-TR-K7.2 and first verification (only for cooling and media water, selection "C and D")		8
Further designs		
Please add "-Z" to Order No. and specify Order code		
Certificate		
Including factory test report (certificate) of FUE950	ALWAYS INCLUDED	
Cooling, setup for non water		
Water/glycol setting for media type "Tyfocor LS (R)" (only with neutral label, no verification and approval)		C 0 2
Optional settings/programming		
Tariff function settings (specify in clear text, up to max. 20 characters)		D 0 2
Pulse output setting of option module (specify in clear text, up to max. 20 characters)		D 0 6
Pulse input setting of option module (specify in clear text, up to max. 20 characters)		D 0 8
Pulse input setting of 4 ... 20 mA option module (please specify 20 mA related type and value in clear text, up to max. 20 characters)		D 1 0
Special display units		
Flow in 'GPM' and Volume in 'gal' (x100) (digits/resolution as selected above, only with 0 digit resolution)		L 0 5
Temperature in deg. F (digit resolution as selected above)		L 3 1

4

Flowmeter SITRANS FUE950 operating instructions, accessories and spare parts

Operating instructions

Description	Order No.
• English	A5E03424739

This device is shipped with a Quick Start guide and a CD containing further SITRANS F US literature.

All literature is also available for free at:
<http://www.siemens.com/flowdocumentation>

Accessories

Description	Order No.
Infrared optical head (Bluetooth type) for data acquisition & programming of FUE950	A5E02611768
Bracket for SITRANS FUE950 wall mounting (20 pcs.)	A5E02611769
Cable for data acquisition via RS232 PC/D-sub 9F/3 wire	A5E02611774
Verification equipment for calculator FUE950	On request
Basic version of programming software tool for FUE950	free download from internet
Expert version of programming software tool for FUE950	A5E03478951
Test Lab. version of re-programming software tool for FUE950	A5E03461778

Spare parts

Description	Order No.
Add-on modules for FUE950	
Pulse input module (2 inputs)	A5E03461432
Pulse output module (2 outputs)	A5E03461436
Combined pulse in-/output module (2 inputs and 1 output)	A5E03461437
RS232 module (M-Bus protocol)	A5E03461459
RS485 module (M-Bus protocol)	A5E03461512
M-Bus module	A5E03461516
Combined current output module, 2 x passive 4 ... 20 mA	A5E03461583
Connection cable for option modules (types: Pulse, RS232/RS485, M-Bus, mA) (special connection cable with 2 plugs)	A5E03461585
Power supply for FUE950 (as spare part)	
3.6 V D-cell battery for SITRANS FUE950	A5E03461708
230 V AC supply module (incl. internal fuse T50 mA L 250 V and back-up battery) for SITRANS FUE950	A5E03461717
24 V AC supply module for SITRANS FUE950, incl. back-up battery	A5E03461719
Pocket for temperature sensors Pt500 (for related 4-wire Pt500 type only, 1 pc.)	
Stainless steel pocket (1 pc.), 135 mm length for 6 mm sensor diameter, max. PN 40 and max. 5 m/s (recommended for 140 mm sensor length).	A5E03462868
Stainless steel pocket (1 pc.), 225 mm length for 6 mm sensor diameter, max. PN 40 and max. 5 m/s (recommended for 230 mm sensor length).	A5E03462870

Description	Order No.
Pt500 4-wire temperature sensor pair, with MID MI004 and PTB K7.2 approvals and verification (for related 4-wire sensor pocket types only)	
Pt500 sensor pair (6/140 mm), 4-wire with 5 m connection cable, 6 mm sensor diameter and 140 mm sensor length. MID approved DE-06-MI004-PTB011, PTB approved 22.77/09.01 (mentioned approvals are only valid if temp. sensors are used with the applicable temperature sensor pockets).	A5E03462872
PT500 sensor pair (6/230 mm), 4-wire with 5 m connection cable, 6 mm sensor diameter and 230 mm sensor length. MID approved DE-06-MI004-PTB011, PTB approved 22.77/09.01 (mentioned approvals are only valid if temp. sensors are used with the applicable temperature sensor pockets).	A5E03462878
FUE950 enclosure	
Bottom part of FUE950 enclosure (1 pc.)	A5E03461508
Snap fit for FUE950 enclosure (1 pc.)	A5E30461731
Pocket for Pt500 temperature sensors (for 2-wire Pt500 types only)	
Brass pocket 6 mm, G½B x 40 mm (PN 16), 1 pc.	A5E02611778
Brass pocket 6 mm, G½B x 85 mm (PN 16), 1 pc.	A5E02611779
Brass pocket 6 mm, G½B x 120 mm (PN 16), 1 pc.	A5E02611780
Stainless steel 6 mm, G½B x 85 mm (PN 25), 1 pc.	A5E02611781
Stainless steel 6 mm, G½B x 120 mm (PN 25), 1 pc.	A5E02611783
Stainless steel 6 mm, G½B x 155 mm (PN 25), 1 pc.	A5E02611792
Stainless steel 6 mm, G½B x 210 mm (PN 25), 1 pc.	A5E02611793
Pt500 temperature sensor pair, 2-wire cable, 6 mm sensor diameter, with MID/EN-approval (for 2-wire sensor pocket types only)	
Cable length:	
2 m	A5E02611794
3 m	A5E02611795
5 m	A5E02611796
10 m	A5E02611798

Schematics

Electrical connection for SITRANS FUS380/FUE380/FUE950 and MAG 5000/6000/FUE950

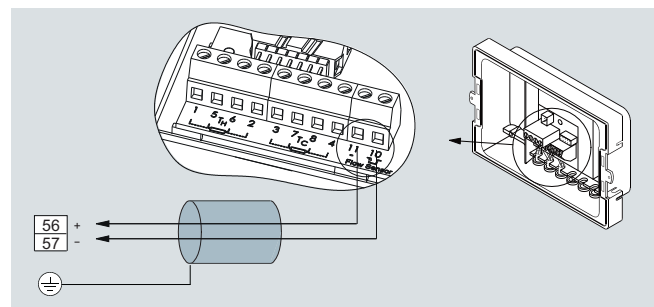

The diagram shows the connection between SITRANS FUE950 (terminals 10 and 11) and FUS380/FUE380 and MAG 5000/6000 (terminals 56 and 57). Temperature sensors must be connected to terminals 5 and 6 (T_+) and 7 and 8 (T_c).

Note:

The right flowmeter pulse output value must be equal to the FUE950 pulse input value and must be checked via the user menu of the transmitter MAG 5000/6000 or nameplate of FUE380 or FUS380.