

Thermo Scientific AquaSensors
DataStick measurement system
for universal plug & play

Product Specifications

Thermo Scientific AquaSensors DataStick

Dissolved Oxygen (ppm and ppb)
Measurement System

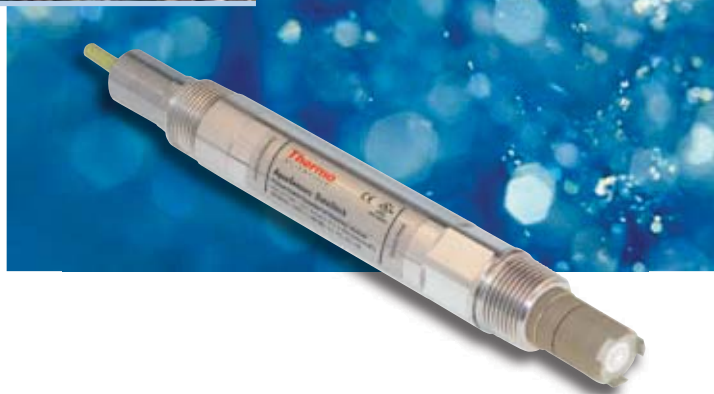

Markets/Applications

- Municipal and industrial wastewater
 - Aeration tanks
 - Aerobic digesters
 - Plant effluent monitoring (NPDES Permit Holders)
 - Anaerobic digesters
- Aquaculture
- Brewing
- Fermentation
- Bio-processing
- Many applications also exist in chemical process, food and dairy, pulp and paper, and other process industries.
- Boiler feed water (ppb)
- Pharmaceutical (ppb)
- Semiconductor manufacturing (ppb)
- Ultrapure water (ppb)
- Power plants (ppb)

AquaSensors D.O. DataStick™

- Clark cell technology
- Pre-calibrated (no field calibration required)
- Plug & play sensor heads
- Rugged, foul resistant membrane
- Electrode protection options
- Simple membrane cap replacement
- Direct data reporting (24-bit)
- Plug & play industrial communications adapters

Connect this D.O. sensor directly to a PLC (Programmable Logic Controller) for seamless integration with industrial control systems. Use any computer to display data, calibrate and customize the measurement without an intermediate analyzer electronics box. Sensor heads are pre-calibrated and can be replaced or exchanged with any other type of sensor without taking the system down. Save space, time and money.

Engineering Specifications

1. The D.O. sensor shall use three-electrode polarographic Clark Cell technology consisting of a silver reference electrode, a silver anode and a gold cathode.
2. The sensor shall have hex-shaped wrench flats to facilitate mounting, and shall be constructed of a material with exceptional chemical resistance and mechanical strength. This material shall enable the sensor to be installed in metal fittings without leakage usually caused by heating and cooling cycles when dissimilar materials are threaded together.
3. The sensor shall have interchangeable, pre-calibrated plug-in sensor heads and communications adapters that can be installed without powering down the system.
4. The sensor shall have 1 inch NPT threads on both ends to mount into a standard 1 inch pipe tee, a 1.5 inch union mounting, or immersion mounting hardware and ball-float assemblies
5. The built-in electronics of the sensor shall be completely encapsulated and O-ring sealed for protection from moisture and humidity.
6. The sensor shall have a built-in pre-amplifier, universal signal conditioning electronics, universal engineering units conversion, and interactive communications with a host computer or display interface using one of several protocols including Modbus® RTU, DeviceNet, Profibus, USB, CANopen or Ethernet.
7. The sensor shall have an integral temperature sensor to measure temperature independently.
8. Replaceable membranes cartridges shall have a pre-installed 50 micron thick gas permeable membrane.
9. The sensor shall be Thermo Scientific AquaSensors Dissolved Oxygen DataStick.

Thermo Scientific DataStick Analytical System

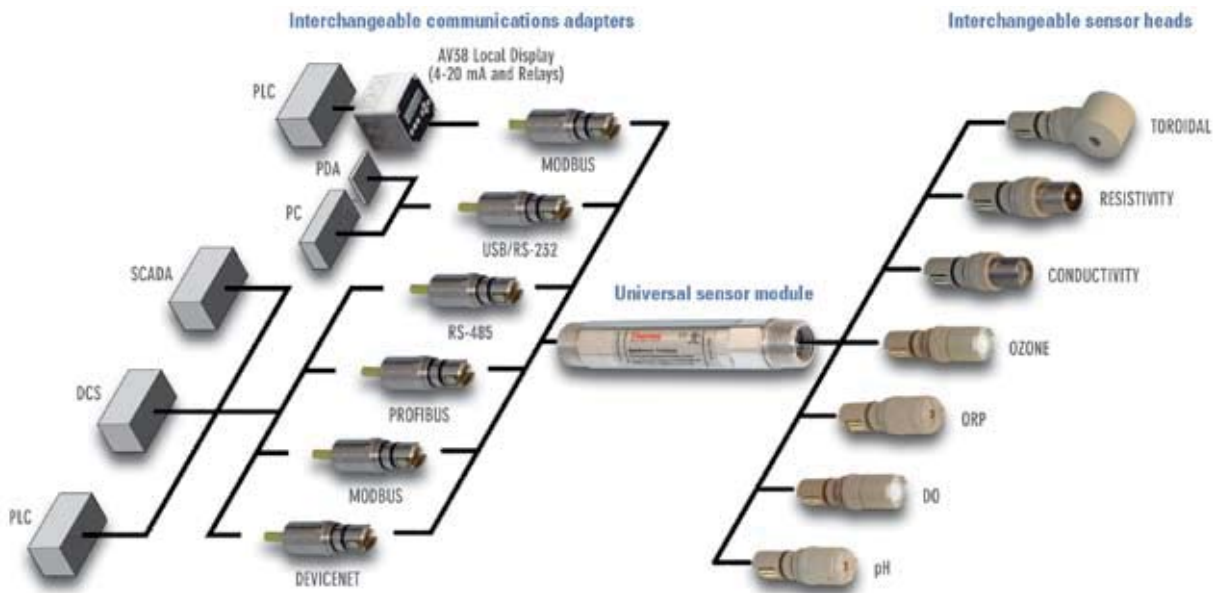

Key Components

DataStick

Provides universal conversion of sensor signals and interactive communications for measurement, calibration, configuration and diagnostics.



Dissolved Oxygen Sensor Head

Pre-calibrated for dissolved oxygen and temperature. Can be plugged into any DataStick to yield accurate 24-bit data.



Communications Adapter

Plugs into the DataStick to provide power and direct interactive communications with control systems.



AV38 Local Display/Controller

2 line display and 7 key navigation. Data reporting with up to 2 current outputs. 2 Form C relays. Digital communications.



Thermo Scientific AquaSensors D.O. DataStick

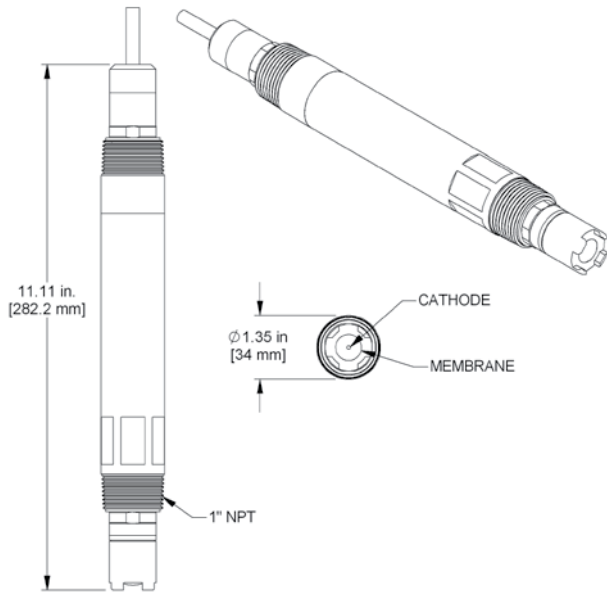

Provides universal conversion of sensor signals and interactive communications for measurement, calibration, configuration and diagnostics. Mounting adapters, junction boxes and recharge kits are available.



Low Flow Chamber



Ball Float Assembly

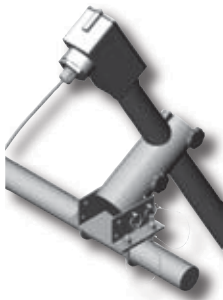

Hand Rail Mounting Assembly



Immersion Mounting with Junction Box

Specifications	
Measurement System Performance†	Range: 0 to 40 ppm, 0 to 200% saturation Resolution: 0.01 ppm Accuracy: 1% of reading Step Response Time: 90% in 90 seconds
Operational Environment	Temperature Range: -5 °C to 50 °C Maximum Pressure: 65 psig @ 50 °C Maximum Flow Rate: 10 ft/second
Power Requirements	Voltage Range: 10 to 30 VDC Maximum Power: 200 mW Typical Power: 120 mW
Construction	Process Electrodes: Gold cathode, silver anode, silver reference (3 electrode polarographic clarkcell) Membrane: PTFE/FEP O-rings: Viton (other materials available) Sensor Head Material: PEEK DataStick Material: 316 stainless steel, PEEK or CPVC Weight: 1.2 lbs (PEEK or CPVC) 2.6 lbs (316 stainless steel)
Units of Measure	Measurement units: ppm, % Temperature Units: °C, °F
Calibration††	Air: Automatically adjusts for set pressure Sample: 1 point Zero: 1 point Temperature 1 point
Compensation Options	Salinity: 0 mS/cm to 999.9 mS/cm Pressure: 539.2 mm Hg to 792.4 mm Hg Temperature: Automatic from -5 °C to 50 °C
Other Configuration Options	Sensor Filter: 0 to 100 seconds Temperature Filter: 0 to 100 seconds
Approvals and Ratings	Immunity & Emissions: CE Certified 89/336/EEC: CISPER 11, EN61000 (-4-2,-4-3,-4-4,-4-6, 4-8) Safety: cULus Listed; 367G E303570 Hazardous Locations: Haz Loc Class 1, Division 2, Groups A, B, C, D. Max Ambient 50 °C

† Note: Typical at 25 °C Performance unaffected by cable length

‡ Note: Class II DC power supply required

†† Note: D. O. and Temperature are precalibrated at the factory