

Sentinel

Panometrics Custody Transfer Gas Ultrasonic Flowmeter

Applications

The Sentinel flowmeter is a complete ultrasonic flowmeter system for the measurement of natural gas flow applications such as:

- Custody transfer
- Transmission and distribution
- Underground storage
- Pipeline balancing
- Power systems
- Gas processing
- Compressor station metering
- Gas production
- Fuel monitoring

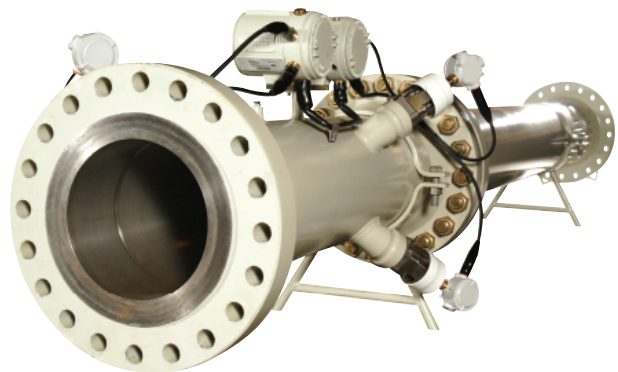

Features

- Netherlands Measurement Institute (NMI) approval
- Compliant with AGA Report #9
- Accuracy 0.1% of reading
- Isolated from upstream flow disturbances
- 40:1 or better turndown ratio



High Accuracy for Custody—Transfer Applications

The Sentinel ultrasonic flowmeter is designed to meet the high-accuracy requirements of AGA9 for natural gas custody transfer, as well as the NMI pattern approval.

A Sentinel meter body is composed of a length of carbon steel pipe with flanged ends, rated to the pressure requirements of the individual installation, and two pairs of pre-installed ultrasonic transducers. The system is factory assembled and tested to ensure that it meets strict quality control standards.

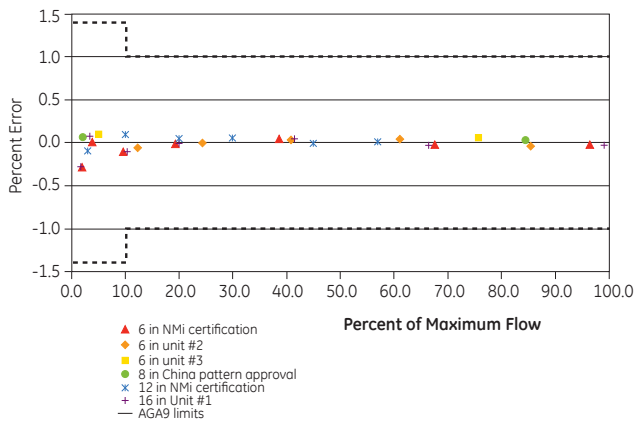

Sentinel performance plots, various size flow cells

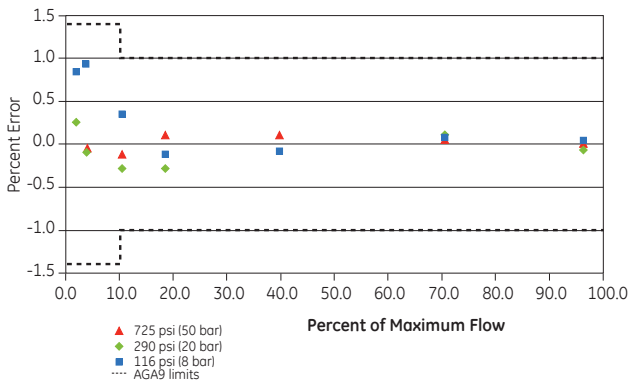

Sentinel performance plots, same flow cell at various pressures

Advanced Ultrasonic Transducer Technology—High Power for High Velocity

The heart of ultrasonic measurement is the transducer. The Sentinel T11 transducer is specifically designed for natural gas applications. Our transducers provide high transmission power through the gas, ensuring optimal performance under high flow conditions of up to 118 ft/sec (36 m/s). The robust all-welded metal design ensures resistance to corrosion and pressure cycling. The transducer frequency is matched to the pipe size of the system ordered. In addition, the Sentinel transducer holder includes unique acoustic isolation characteristics that allow optimal performance, even in noisy applications such as wet natural gas.



Sentinel T11 transducer

How Correlation Transit-Time™ Measurement Works

Ultrasonic transducers are installed in the meter body, one upstream of the other. The transducers send and receive ultrasonic pulses through the fluid. The meter measures the difference between the upstream and downstream transit times, and uses digital signal processing and correlation detection to calculate velocity and volumetric flow rate.

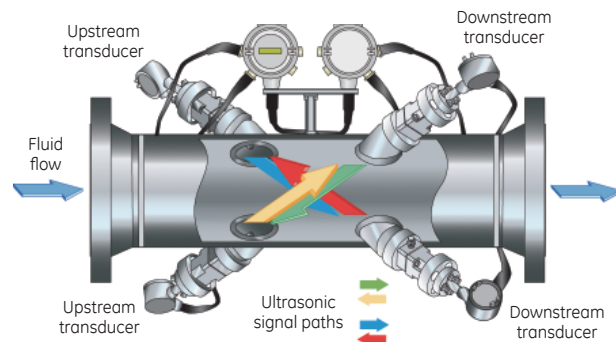

Transit-time flow measurement technique

System Design

A complete Sentinel system consists of the ultrasonic meter, flow conditioner, and upstream/downstream piping. This configuration removes the uncertainty associated with installation effects (distorted flow profile caused by valves, elbows, other piping system components) on the overall meter performance. This solution provides a simplified, yet cost effective metering system without exposing the user to any additional risk in measurement uncertainty. Customers can be assured of accurate flow measurements because flow profile, a major source of uncertainty if not fully developed and uniform, is removed from the overall equation in the ultrasonic flowmeter system.

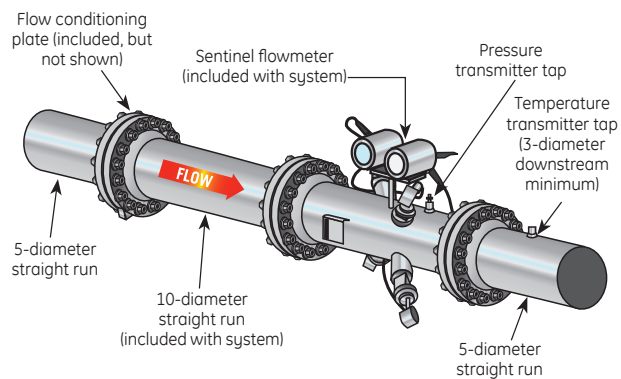

The Sentinel path configuration is designed such that a minimum number of paths interrogates the maximum area of the pipe, resulting in measurement stability and superb repeatability. In addition, the meter uses no bounced or multiple bounced paths susceptible to signal distortion from build-up on walls and adversely affected by ultrasonic noise (often from upstream piping and valving) and high flow velocity. The straight single path provides a solid measurement and maximizes the long-term performance of the meter.

The Sentinel flow metering system operates with a better than 5 Hz response rate, depending on pipe size, using a sophisticated multi-mode signal processing technique that delivers accurate and dependable meter performance with high turndown. This fast sampling ensures that system accurately measures flow under dynamic and pulsating flow conditions.

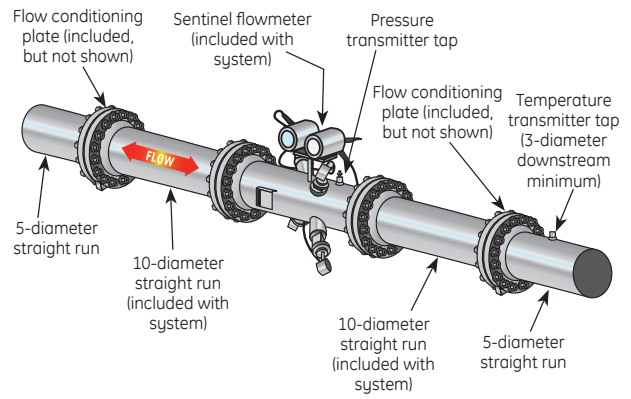

Bidirectional Sentinel flowmeter installation

Flow Conditioning System

The Sentinel system includes a flow profile conditioning plate and a straight pipe run of ten diameters upstream of the Sentinel meter body. The system requires the customer to provide a minimum of five-diameter straight pipe run both upstream and downstream of the installation. When used in a bidirectional flow application, the Sentinel system includes an additional flow profile conditioning plate and ten diameters of straight pipe run on the downstream side of the flowmeter. The customer-provided five-diameter pipe runs upstream and downstream are still required.

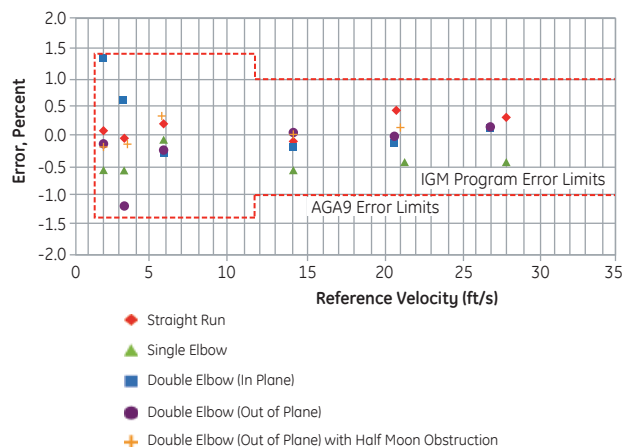

Corrected error percent vs. velocity, 10 in (25 cm) IGM spool with CPA-50E® (Name CPA-50E used with permission), 3.5 Dup/10 Ddown, repeat runs

Performance in Air/Natural Gas (NG) at Atmospheric Pressure

Although Sentinel is designed to operate at natural gas transmission line pressures, it has been proven to work well in air at ambient pressure. This is made possible by Sentinel's advanced ultrasonic transducers and the associated electronics and signal-processing platform used. There is no minimum pressure requirement for proper operation of the metering system. In addition, variable pressures exhibit virtually no effect on the Sentinel's flow measurement.

Meter performance can be verified in the field during commissioning using atmospheric pressure air to ensure the meter system is ready to go when needed. Thus, customers will have a high degree of confidence in the installation and performance of the meter prior to line pressurization with natural gas.

Removable Transducer Option

The Sentinel flowmeter is available with optional isolation valves on each installation port. This permits the removal of transducers under process pressure. A single hydraulic ram system is required for safety and to simplify the re-installation process.



Convenient Installation

The Sentinel flowmeter electronics are preprogrammed with all system setup information. The system is ready to use as soon as the meter body is installed and the power and meter communications are wired. No additional setup or configuration are needed.

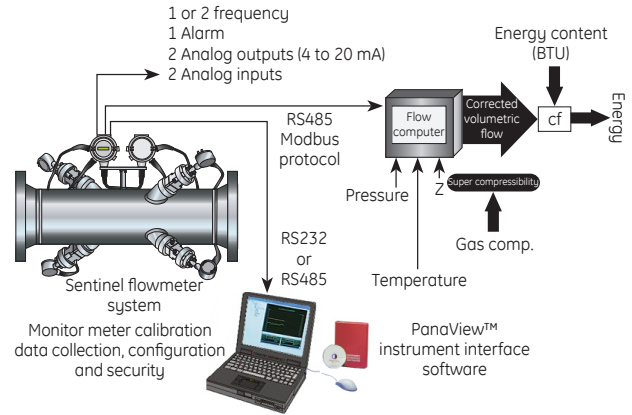

Typical system configuration. PanaView software provides a communication interface between the Sentinel system and a laptop PC.

PanaView™ Instrument Interface Software

PanaView software facilitates communication between a PC and the Sentinel system or other GE Sensing products. This software monitors your Sentinel flowmeter to provide a secure, comprehensive check on meter configuration with a full audit trail. It also allows live flow readings and tracking of flow diagnostics.

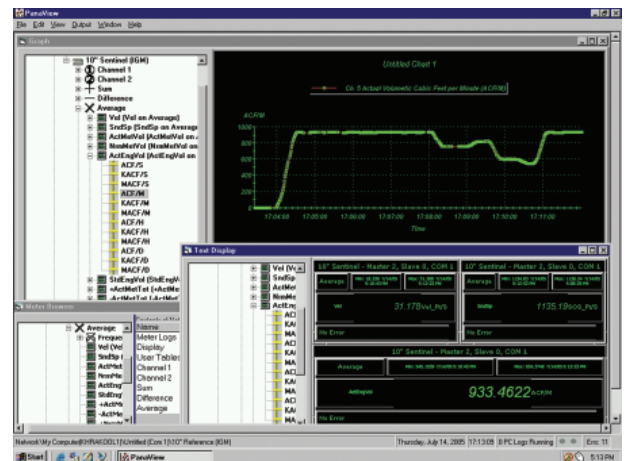

Example of PanaView display

Nominal Pipe Size in (mm)	Weight Flange Class (ANSI B16.5)			Face-to-Face in (mm)	*Height 'h' in (mm)	*Width 'w' Distance in (mm)
	300 lb	600 lb	900 lb			
4 (100)	236 lb (107 kg)	270 lb (122 kg)	304 lb (138 kg)	32 (813)	35 (889)	34 (864)
6 (152)	387 lb (176 kg)	473 lb (215 kg)	568 lb (258 kg)	45 (1143)	37 (940)	36 (914)
8 (203)	470 lb (213 kg)	593 lb (269 kg)	794 lb (360 kg)	48 (1219)	39 (991)	38 (965)
10 (254)	581 lb (264 kg)	832 lb (377 kg)	1048 lb (475 kg)	52 (1321)	42 (1067)	40 (1016)
12 (305)	731 lb (332 kg)	1014 lb (460 kg)	1401 lb (635 kg)	56 (1422)	44 (1118)	42 (1067)
14 (356)	905 lb (411 kg)	1331 lb (604 kg)	1881 lb (853 kg)	58 (1473)	46 (1168)	44 (1118)
16 (406)	1067 lb (484 kg)	1747 lb (792 kg)	2302 lb (1044 kg)	60 (1524)	48 (1219)	46 (1168)
18 (457)	1259 lb (571 kg)	2031 lb (921 kg)	3003 lb (1362 kg)	63 (1600)	50 (1270)	48 (1219)
20 (508)	1528 lb (693 kg)	2557 lb (1160 kg)	3765 lb (1708 kg)	67 (1702)	53 (1346)	50 (1270)
24 (610)	2255 lb (1023 kg)	3691 lb (1674 kg)	6386 lb (2897 kg)	74 (1880)	57 (1448)	54 (1372)

*Extra clearance needed for insertion mechanism

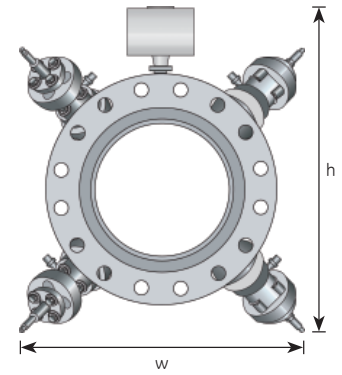

Nominal Pipe Diameter in (mm)	Velocity (ft/sec)		Actual Volumetric Flow Rate (ACFM)	
	minimum	maximum	minimum	maximum
4 (100)	3.8	118	18	626
6 (152)	2.4	118	26	1420
8 (203)	2.4	118	46	2460
10 (254)	2.4	118	72	3877
12 (305)	1.5	89	64	4151
14 (356)	1.5	89	77	5017
16 (406)	1.5	89	101	6553
18 (457)	1.5	89	128	8295
20 (508)	1.5	89	158	10,307
24 (610)	1.5	89	228	14,908

Nominal Pipe Diameter in (mm)	Velocity (m/sec)		Actual Volumetric Flow Rate (m ³ /hr)	
	minimum	maximum	minimum	maximum
4 (100)	1.15	36	34	1064
6 (152)	0.72	36	44	2416
8 (203)	0.72	36	76	4183
10 (254)	0.72	36	120	6593
12 (305)	0.45	27	106	7019
14 (356)	0.45	27	128	8483
16 (406)	0.45	27	168	11,082
18 (457)	0.45	27	213	14,027
20 (508)	0.45	27	264	17,430
24 (610)	0.45	27	382	25,209

Sentinel Specifications

Operation and Performance

Meter is designed to meet or exceed the requirements of AGA Report Number 9.

Fluid Types

Natural gas (other gases available upon request)

Pipe Sizes

4 in to 24 in (100 mm to 600 mm)

Other sizes available upon request.

Meter Body Materials

Carbon steel (A106 Gr. B or A333 Gr. 6) pipe section with carbon steel (A105 or A350 LF2) flanges and fittings

Specify A333 Gr. 6 and A350 LF2 for low-temperature service.

Maximum Error (Without Flow Calibration)

- $\pm 0.5\%$ between $0.1 Q_{\text{maximum}}^*$ and Q_{maximum}
- $\pm 1.0\%$ between Q_{minimum} and $0.1 Q_{\text{maximum}}^*$

Repeatability

- 0.08% between $0.1 Q_{\text{maximum}}^*$ and Q_{maximum}
- 0.15% between Q_{minimum} and $0.1 Q_{\text{maximum}}^*$

Resolution

0.003 ft/s (0.001 m/s)

Velocity Sampling Interval

0.2 seconds

Maximum Peak-to-Peak Error

$\pm 0.2\%$ between $0.1 Q_{\text{maximum}}^*$ and Q_{maximum}

**(0.15 Q_{maximum} for 4" meter size)*

Zero Flow Reading

- < 0.007 ft/s ($.00213$ m/s) for each acoustic path
- < 0.01 ft/s ($.00305$ m/s) composite for all paths

Accuracy can be improved with high pressure NG flow calibration.

Meter Performance

- Flow calibrated accuracy is 0.1% of reading relative to lab
- Absolute accuracy is 0.3% including lab uncertainty

Specifications assume 5 diameters upstream and 5 diameters downstream of straight pipe run in addition to the pipe run and flow conditioning plates provided with the Sentinel system, and a flow velocity greater than 5 ft/s (1.5 m/s).

For Pipe Sizes 4 in to 10 in (15 cm to 25 cm)

- Maximum actual measurable velocity: ± 118 ft/s (± 36 m/s)
- Minimum actual measurable velocity: ± 2.4 ft/s (± 0.72 m/s)
- Transitional flow velocity: 11.8 ft/s (3.6 m/s); QT = 10% (QT = 15% for 4" meter size)

For Pipe Sizes 12 in to 24 in (30 cm to 61 cm)

- Maximum actual measurable velocity: ± 88.6 ft/s (± 27 m/s)
- Minimum actual measurable velocity: ± 1.48 ft/s (± 0.45 m/s)
- Transitional flow velocity: 8.86 ft/s (2.7 m/s); QT = 10%

Maximum operating gas pressure @ 176°F (80°C)

	ANSI Flange Class		
	300 lb	600 lb	900 lb
MAOP psig (bar)	690 psig (47 bar)	1381 psig (95 bar)	2072 psig (143 bar)

Electronics

Flow Measurement

Correlation Transit-Time mode

Enclosures

US: Epoxy-coated aluminum
Weatherproof Type 4, IP66
Class I, Division 1, Groups B,C&D
FM and CSA

European: Flameproof

Ⓔ II 2 GD EEx d IIC

Dimensions

Main enclosure
Weight: 10 lb (4.5 kg),
Size (h x d): 8.2 x 6.6 in (208 x 168 mm)

Power Enclosure

Weight: 25 lb (11.3 kg),
Size (l x h x d): 15 in x 10 in x 8 in (381 mm x 254 mm x 203 mm)

Display

2-line x 16-character LCD display, LED backlight, configurable to display up to four measurement parameters in sequence

Power Supplies

Standard: 95 to 240 VAC $\pm 10\%$, 50 to 60 Hz $\pm 2\%$
Optional: 17 to 32 VDC, $\pm 10\%$

Note: For DC-powered meters, Class 2 rated supplies must be used for the line power.

Power Consumption

20W maximum

Operating Temperature

-40°C to 60°C (-40°F to 140°F)

Storage Temperature

-55°C to 75°C (-67°F to 167°F)

Standard Inputs/Outputs

- Two 0/4 to 20 mA isolated outputs, 600 W maximum load
- One frequency (HF) output, optically isolated, from DC to 10 kHz maximum
- One hermetically sealed Form C alarm relay. Can be applied to indicate flow direction or fault.
- Two isolated 4 to 20 mA inputs and 24 V loop power for pressure and temperature
- Optional 2 HF outputs and two alarm output or 1 HF output and 4 to 20 mA inputs

Digital Interfaces

- Bidirectional RS232 or RS485 link to PanaView Software
- RS485 Modbus® digital output

Audit Capacity

- Password security protected
- Log file of all critical parameters not erasable
- Totalizer hardware secured/seal

European Compliance

System complies with 73/23/EEC LVD (Installation Category II, Pollution Degree 2), PED Cat III, Module H

Wetted T11 Ultrasonic Flow Transducers

Temperature Range

-30°C to 80°C (-22°F to 176°F)

Pressure Range

- 300 lb ANSI flange class: 740 psig (51 bar) maximum allowable operating pressure at 100°F (38°C)
- 600 lb ANSI flange class: 1,480 psig (103 bar) maximum allowable operating pressure at 100°F (38°C)
- 900 lb ANSI flange class: 2,220 psig (153 bar) maximum allowable operating pressure at 100°F (38°C)
- Other pressure rating available upon request.

Materials

- Transducer: Titanium CP Gr. 2 (B348/B381)
- Transducer holder: Stainless steel 316/316L (A276)C

Area Classifications

- North America: Explosion-proof Class I, Division 1, Groups B,C,&D
- European: Flameproof  II G EEx d II
- PED 97/23/EC

Transducer Cables

Integrated cables: Potted mineral insulated cable (North America) or armored cable with ATEX-certified cable glands (European)

Metrological Approval for Sentinel



Nederlands Meetinstituut

NETHERLANDS



www.gemeasurement.com

920-055F