

4210 Ultrasonic Flow Meter

The Model 4210 Pocket Guide is provided as a handy field reference. It is not intended to replace the Model 4210 Instruction Manual, but complements it by providing condensed instructions. Study the manual thoroughly before installing or operating the flow meter.

© Copyright 1994, 2004 by
Teledyne Isco, Inc.,
4700 Superior St.,
Lincoln, Nebraska, U.S.A. 68504
Phone: (402) 464-0231
Toll Free: (800) 228-4373
FAX: (402) 465-3022

Part #60-3213-254
Revision H, May 10, 2006

www.isco.com



WARNING

The installation and use of this product may require you to work in locations where you could be seriously injured or even killed. Take whatever precautions are necessary to ensure your safety before entering the installation. Never work alone or unsupervised. Install and operate this product in accordance with all applicable safety and health regulations, as well as any appropriate local ordinances.

This product is often installed in confined spaces. Examples of confined spaces are manholes, pipelines, digesters, and storage tanks. These places can be dangerous or fatal if you are not suitably prepared. The primary hazards are the presence of poisoned air, the lack of ventilation, and the possibility of falls. Other hazards may be present, as well. Work in such places is governed by OSHA 1910.146, and may require a permit before entering.

Material Safety Data Sheets (MSDS) for chemical agents supplied or recommended for use with this product are in the MSDS Appendix in the back of the instruction manual. These sheets provide information about possible hazards from the chemicals. Additional MSDS, covering various proprietary agents (name-branded or trademarked mixtures) that can also be used with this product, are available from the manufacturers of those agents.

This pocket guide uses the following notations to indicate hazard warnings:



DANGER

DANGER describes situations, which if not avoided, will result in loss of life or serious personal injury. The emphasis is on a clear and immediate threat to your safety.



WARNING

WARNING describes situations, which if not avoided, could result in loss of life or serious personal injury. The emphasis here is on the potential for a serious accident.



CAUTION

CAUTION describes situations, which if not avoided, may result in moderate personal injuries, property damage, or damage to the equipment.

Table of Contents

1.

Getting Started

- 1.1 Becoming Familiar with the Model 4210
1-1
- 1.2 Selection of a Power Source 1-2
 - 1.2.1 Turning the Flow Meter On .. 1-3
- 1.3 Checking the Installation 1-3
- 1.4 Options and Capabilities 1-7
- 1.5 Connection to a Sampler 1-8
- 1.6 Adjusting Level 1-8
- 1.7 Data Acquisition and Storage (Flowlink)
1-10
- 1.8 Parameter Sensing with the Model 4210
1-11

2.

Programming Introduction

- 2.1 Operation of the Keypad and Display ..
2-2
- 2.2 Keypad Functions 2-4
- 2.3 Programming Procedure 2-6
- 2.4 Description of Program Steps 2-9
 - 2.4.1 Step 1 - Operating Mode 2-9
 - 2.4.2 Step 2 - Flow Conversion Type ..
2-11
 - 2.4.3 Step 3 - Adjust Level, Parameters
2-14
 - 2.4.4 Step 4 - Reset Totalizer 2-16
 - 2.4.5 Step 5 - Sampler Pacing 2-17
 - 2.4.6 Step 6 - Sampler Enable 2-18
 - 2.4.7 Step 7 - Alarm Dialout Mode 2-19
 - 2.4.8 Step 8 - Printer 2-20
 - 2.4.9 Step 9 - Reports/History 2-21

3.

Programming

- 3.1 Step 1 - Operating Mode 3-1
- 3.2 Step 2 - Flow Conversion (Level-to-Flow)
3-38
 - 3.2.1 Enter Maximum Head 3-46
 - 3.2.2 Programming the 4–20 mA
Outputs 3-47
- 3.3 Step 3 - Port to Adjust 3-49
- 3.4 Step 4 - Reset Totalizer 3-56
- 3.5 Step 5 - Sampler Pacing 3-57
- 3.6 Step 6 - Sampler Enable 3-61
- 3.7 Step 7 - Alarm Dialout Mode 3-67
- 3.8 Step 8 - Printer Setup 3-72
- 3.9 Step 9 - Reports/History 3-76

4.

Maintenance

- 4.1 Care of the Flow Meter Case 4-1
 - 4.1.1 Care of the Case Seal 4-2
 - 4.1.2 Preventing Moisture Damage 4-2
- 4.2 Changing the Printer Paper and Ribbon
4-3
 - 4.2.1 Ink Ribbon Replacement 4-6
- 4.3 Care of the Ultrasonic Level Sensor . 4-7
- 4.4 Cable Inspection 4-8
- 4.5 Maintenance of the Batteries 4-8
 - 4.5.1 Charging the Nickel-Cadmium
Battery 4-9
 - 4.5.2 Five-Station Battery Charger . . .
4-10
 - 4.5.3 Self-Discharge Characteristics . .
4-10
 - 4.5.4 Hazards of Overcharging . . . 4-11
 - 4.5.5 Charging from Another Source . .
4-11
 - 4.5.6 Internal Fuse 4-12
 - 4.5.7 Using the Lead-Acid Battery 4-12

4.5.8 Using Other Types of Batteries . . .	4-14
4.5.9 Attaching the Battery	4-14
4.6 Regenerating the Desiccator	4-15
4.6.1 Regenerating the Internal Case Desiccant	4-15

4210 Ultrasonic Flow Meter

Section 1 *Getting Started*

1.1 Becoming Familiar with the Model 4210

The Model 4210 is a microprocessor-equipped flow meter capable of measuring flow rate in a wide variety of open channel flow situations. The Model 4210 uses the ultrasonic method for sensing level. An ultrasonic level sensor mounted over the flow stream transmits a pulse to the liquid surface and then “listens” for the reflected echo from the stream. By measuring the time between pulse and echo, the flow meter can calculate the distance between the level sensor and the flow stream. By comparing this distance with a referenced “zero” level for the flow stream, the flow meter can calculate the liquid level.

The flow meter converts the detected echo from the ultrasonic transducer to a level reading. Built-in level-to-flow rate tables convert the level to flow rate. The level and flow rate appear on a two-line, eighty character liquid crystal display (LCD). Model 4210 Flow Meters

are equipped with an internal printer to provide a continuous printed record of level, flow rate, and other information that may be used for later reference. The Model 4210 also has memory allocated that you can set up to store level and other data. You must use Flowlink[®], Teledyne Isco's proprietary data processing and acquisition software to initialize (set up) and access this memory.

1.2 Selection of a Power Source

Teledyne Isco offers a variety of power sources to operate the flow meter. For commercially-powered installations, there is the AC Power Supply. Also available is a power supply with a 1.2 Ah (Ampere-hour) standby battery built in, the Battery-Backed Power Supply. For applications where there is no AC power connection available, Teledyne Isco offers a 4 Ah nickel-cadmium battery, or a 6 Ah gelled-electrolyte (Lead-Acid) battery. All these power sources mount on top of the flow meter and are secured with rubber draw catches. The cable with the two-pin connector (12 volt) attaches to the +12 VDC connector on the flow meter.

Battery life expectancy will vary from about one to twelve days between recharge cycles, depending on the frequency of level reading intervals and the setting for the printer chart speed. For very remote sites where changing the battery is difficult, Teledyne Isco offers the Solar Panel Battery Charger, used with the

Lead-Acid Battery. You may also power the Model 4210 with a deep-cycle R-V or marine battery. You must mount these larger batteries externally, as they are quite large. Teledyne Isco offers a special connect cable for them.

1.2.1 Turning the Flow Meter On

After you have connected the flow meter to power, you can turn the flow meter on with the ON button located on the keypad. If you have an ultrasonic level sensor attached to the flow meter you will hear a clicking sound and a level reading will appear on the display. If there is no level sensor attached, there will be a zero level reading and it will have an asterisk (*) after it. The asterisk indicates an error reading. If you connect the level sensor and point it at some solid object, you should get a reading that indicates the flow meter is receiving a return echo.

1.3 Checking the Installation

At the job site it is worthwhile to check the installation to see that it was made correctly and to make sure nothing has changed that could affect the accuracy of the measurements. If the flow meter or ultrasonic level sensor are installed in a sewer or manhole, please read and observe the following warning:



DANGER

YOU CAN BE KILLED working in sewers or manholes if you do not follow proper safety procedures. Aside from the obvious danger of falling, poisonous gases present in most sewers can overcome you quickly without any warning. Safety information is provided in the Model 4210 Instruction Manual in Appendix 1. Please read and follow these procedures and take any other precautions as necessary; the life you save may be your own.

Make sure the mounting of the ultrasonic level sensor is stable and secure. A stable mounting is necessary to maintain calibration between the level sensor and the channel. Make sure the sensor is absolutely level. There must be a minimum of 12 inches (30.5 cm) between the level sensor and the highest expected level of the flow stream. This distance is referred to as the “dead band.” Refer to Figure 1-1.

Make sure the ultrasonic level sensor is installed where it is protected from wind and exposure to sunlight. Wind can blow the ultrasonic pulse away and sunlight heating the sensor can cause a temperature differential between the level sensor and the surrounding air. Both these conditions add error to the level calculations. Additional information on factors affecting the accuracy of the ultrasonic level sensor is in Section 3 of the Model 4210

Instruction Manual. A sunshade is available from Teledyne Isco to relieve the solar heating effect. In some instances, a stilling well may help with the wind problem. A stilling well will also calm turbulent flow, which is difficult for an ultrasonic level sensor to measure.

Inside a manhole you can suspend the transducer for level or flow measurement and then calibrate it. However, you should be aware that subsequent movement of the level sensor (such as bumping it when entering or leaving the manhole) can introduce serious error.

Suspension of the ultrasonic level sensor is only acceptable in situations where there is no vibration or significant air movement inside or in a manhole. Detailed information on mounting the ultrasonic level sensor over various flow streams is in the manual.

Accessories are available to assist in mounting and calibrating the ultrasonic level sensor.

They will be described briefly here; further information on them is available from the manual or the factory.

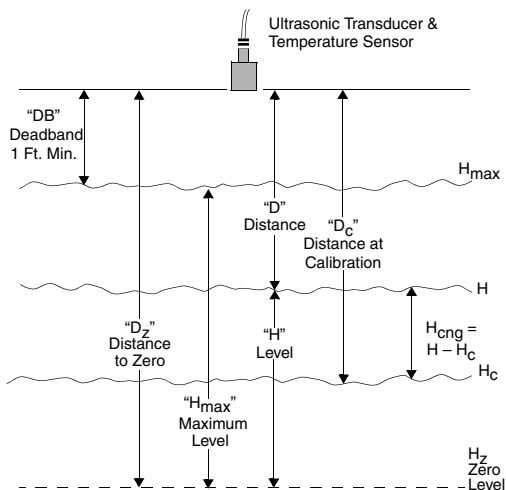

Figure 1-1 Dead Band

Dead Band is the non-usable distance (1 foot) between the level sensor and the liquid surface. This requires that at maximum level the liquid surface be at least 1 foot from the level sensor (or 2 feet for units shipped before June 2004).

D is the distance from the level sensor to the liquid surface.

D_c is the distance from the level sensor to the liquid surface at the time that level “H” was calibrated.

D_z is the distance from the level sensor to the zero level point of the primary device.

Level is the depth of water above the primary device's zero point. Also referred to as "Head." The Model 4210 calculates head by using the following formula: $H = Dz - D$.

Hc is the level at the time the flow meter was calibrated.

H is the level at the time a measurement is to be made. "H" is shown above "Hc." However, if the level had dropped after calibration "H" would be below "Hc."

Hcng - Level change is the change in level over time. The maximum change for a Model 4210 is 10 feet.

Hmax - Maximum head is the maximum level the flow meter can measure.

1.4 Options and Capabilities

Accessories for the Model 4210 assist installation. The *Spreader Bar* allows installation of the sensor in a manhole. The *Cable Stiffener* stabilizes suspended mounting of the level sensor. The *Mounting Bracket* lets you secure the level sensor to a vertical surface. The *Sunshade* keeps sunlight from heating the level sensor. The *Floor Mount* simplifies close mounting over a stream in a manhole. The *Calibration Target* lets you align the sensor outside the manhole.

1.5 Connection to a Sampler

A Model 4210 Flow Meter can control a sampler in a flow-proportional sampling mode. This means the sampler will take a sample after a specific volume has passed through the flow stream, rather than after an interval of time. This way, the sampler and flow meter compensate for varying flow rates. You can use the Model 4210 with a variety of Isco samplers or samplers made by other manufacturers.

Connecting an Isco Sampler to a Model 4210 requires an Isco flow meter-to-sampler connect cable. The cable is 25 feet long. If you plan to use the sampler enable feature (see Section 2 - Programming), make sure you use the newer cable that has all six pins connected. Older cables do not have a connection between the F pins and this keeps sampler enabling from working. If in doubt, use an ohmmeter or continuity checker to test your cable.

1.6 Adjusting Level

You measure the level in the flow stream with a gauge. It is important to make this measurement as accurately as possible, as the level setting on the flow meter will determine the accuracy of all subsequent level and flow rate measurements made by the flow meter. When you are satisfied that the flow stream has been measured accurately, you can change the level reading on the flow meter to show this reading.

First, make sure the ultrasonic level sensor is properly installed over the flow stream. Then set the level by selecting the Adjust Level/Parameters step in the flow meter program. You can then correct the displayed level by entering the measured level value through the number keys to move the number up or down. When the proper value is displayed, enter the number into memory by pressing the Enter/Program Step key.

✓ Note

It is very important that you measure the level in the stream accurately, as all subsequent calculations of flow will be based on this measurement. If the level value entered is incorrect, all subsequent flow calculations will be incorrect also.

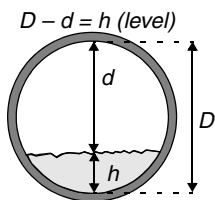

This figure shows a practical method for measuring level in a round pipe. Note that you are actually measuring the distance from the top center of the pipe to the surface of the flow stream. The

level (h), then is the distance from the top center of the pipe, d , subtracted from the diameter of the pipe, D . You must know the correct diameter of the pipe.

1.7 Data Acquisition and Storage (Flowlink)

All 4210 Flow Meters contain memory you can allocate to store level, rainfall, sample, and other data. You can interrogate this information for later processing. To set up the flow meter's memory for data storage, you must use Flowlink, Teledyne Isco's proprietary data acquisition and processing software. Programs from Flowlink let you set up the flow meter for memory initialization, data acquisition, and interrogation from a different location through a Windows[®] computer. The computer and the flow meter connect together through a standard dial-up telephone line with modems. (The modem in the flow meter is an optional accessory.) Multiple flow meters can be initialized and interrogated by the same computer. You can also use Flowlink to access the flow meter at the installation site with a laptop computer plugged into the Interrogator connector on the flow meter. Other programs in Flowlink allow the processing of the data retrieved from the flow meter. Refer to the Flowlink manual for further information.

 Note

Storage of data is not automatic with the Model 4210 Flow Meter. You must use Flowlink software to initialize, partition, size the memory, and also to retrieve and process the stored data.

1.8 Parameter Sensing with the Model 4210

The 4210 also has the capability of displaying, recording, and (if Flowlink software is used) storing data from parameter sensors. The sensors available from Teledyne Isco for the Model 4210 measure temperature, pH (the relative acidity or alkalinity of a solution) and D.O. (dissolved oxygen). The YSI Model 600 Multiparameter Sonde offers pH, D.O., temperature, and conductivity. You can also measure and record rainfall with the Isco Model 674 Tipping Bucket Rain Gauge, which connects to its own port on the flow meter.

All parameter probes require constant and complete submersion in the flow stream for proper operation. Dry operation can damage the pH and D.O. probes. The pH and D.O. probes are extremely sensitive devices and require the use of the Model 201 pH Module and Model 270 D.O. Modules (signal amplifiers) between the probes and the flow meter. The modules are not interchangeable.

 Note

The 270 D.O. module has been discontinued. Probes, service kits, and accessories are still available to maintain existing field units.

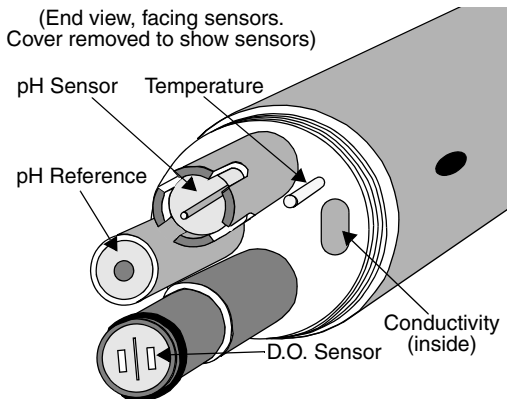

Figure 1-2 YSI 600 Multi-Parameter Sonde

The probes can be installed in a variety of places, but typical installation is in round pipes. Teledyne Isco offers a series of rings that provide simplified mounting for all probes inside round pipes.

- Each probe snap-mounts to a specialized sensor carrier.
- The sensor carrier then attaches to the mounting rings by sliding tabs into mating slots.
- The probe cable is routed from the stream to the parameter module.
- The module is installed and its cable routed to the flow meter's Parameters connector.

Note

The Model 4210 has only one parameter sensing port. You must select temperature, D.O. with temperature, or pH with temperature. (D.O. and pH require temperature monitoring for proper operation.) If you want to change your selection later, you can. You will need the correct probe and module and you will have to change the program in the flow meter.

Note

All brands or product names used in this text are trademarks or registered trademarks, and are the property of their respective companies or organizations.

4210 Ultrasonic Flow Meter

Section 2 *Programming* *Introduction*

To monitor a flow stream, you must program the flow meter and install the level measuring device, an ultrasonic sensor. The installation will usually also include a primary measuring device, a structure placed across a stream that regulates flow. There are nine program steps that control all aspects of the flow meter's operation.

Teledyne Isco ships the flow meter with an installed program called the default program. This program shows the flow meter's capabilities. The flow meter's computer must always have something programmed into the unit, so that becomes the default program. Your flow situation will usually require other programming choices. The text provided with each screen explains the various menu options.

2.1 Operation of the Keypad and Display

The display is a two-line, forty character-per-line liquid crystal (LCD). It has a backlight feature for easy viewing in low light situations. The display has three different operating modes, normal, programming, and messages. In the normal mode, the display shows such things as level, flow rate, total flow, parameter measurement, etc. In the programming mode, the top line of the display shows each step as you work through the program, while the bottom line shows the choices available for that step. In the message mode, the display provides instructional information, such as how to leave programming, or what to do if you have entered an incorrect number.

Following is a “normal” display on the flow meter. This is typical of what the flow meter will display when it is in the normal operating mode and you are not programming it.

0000004.78	CF	1.13	FT	16-MAR-94
1.03	CFS	(X X)		8:25:37

An interpretation of the numbers on this display is as follows: Time and date will be replaced by pH/D.O. and temperature if you are using parameter sensing. The (X X) to the right of the time indicates letters that may appear occasionally on the flow meter.

The letter c will appear when the flow meter is communicating with a remote computer

(FLOWLINK applications only). The letters E or D will appear (Enable or Disable) when the sampler enable function (Step 6) is programmed by condition. (Programmed by condition means that the flow meter will enable the sampler only when a certain condition or set of conditions, sensed by the flow meter, are met.)

Total Flow	Current Level	Date (or pH/D.O.)
Flow Rate	Velocity	Time (temperature)

Following is a typical programming display on the flow meter: (One of the items in the second line will be flashing. The item flashing is the selection currently held in memory.)

TOTALIZED VOLUME UNITS
CF, GAL, M3, AF, L, MGAL

Following is a typical display providing instructional information:

CHANGES HAVE BEEN MADE IN STEP
PRESS '0' TO CONTINUE, PRESS '1' TO DISCARD

 Note

If you stop programming for more than two minutes, the flow meter will time out, and whatever is on the display, (message or program step) will revert to the "normal" display, shown previously.

The program consists of steps and substeps. The steps are listed on the flow meter front panel. Most steps contain several substeps. Generally, you need to complete all the substeps before stopping, or the flow meter will reject the

changes you made for that step after it times out. There are some exceptions.

The flow meter keeps in memory any changes that you made for the finished steps (all substeps completed before stopping). Most steps not finished when you stop will return to the previous selection.

2.2 Keypad Functions

Programming is done on the keypad with prompts from the display. The following sections describe the function of each key.

- **OFF and ON** – These two keys turn the flow meter off and on.
- **Go To Program Step** – Lets you go directly to a program step without passing through the entire program. Enter the number of the step you want with one of the number keys. There are nine program steps, so numbers from one to nine are valid.
- **Exit Program** – Press this key when you want to leave the programming mode and return to the normal operating mode.
- **Clear Entry** – This key lets you return to the previous entry for a program step if you have changed the entry, but not yet pressed Enter.
- **Enter/Program Step** – This key has two functions. One is to enter a program selection into the flow meter's memory

(Enter). The other is to step through the program (Program Step).

- **Print Program** – Pressing this key will make the flow meter print out a complete list of the current program choices retained in memory.
- **Print Report** – The flow meter can print reports of activity at regular intervals. The report contents are defined in step 1. If you set up the flow meter to generate reports, you can have a report printed at any time by pressing this key. The report will cover the time interval from the last scheduled report to the time you press this key.

The flow meter will still print the next report at the next scheduled time. Note that if power fails for five minutes or more, the flow meter will print a report when power is restored covering the interval between the last report and the time power failed. The next report will cover the time from the power failure to next scheduled report time.

- **Chart Advance** – Pressing this key causes the paper chart to advance through the printer at the fastest possible speed. Nothing will be printed while you are holding this key.
- **Chart Reroll** – It is possible to unroll the chart from the take-up roll on the flow meter by pulling it out with your

hands. Pressing this key lets you rewind the chart onto the take-up roll.

- **Number keys** – These keys let you enter numeric values into the flow meter when programming.
- **Decimal Point** – Lets you enter a decimal point for a number. On flow meters equipped with the optional modem, you can use this character as a comma (delay) when entering dialout numbers.
- **Arrow keys** – These keys, referred to as the left and right arrow keys let you select a programming option by moving across the menus shown on the second line of the display.
- **+/- key** – Lets you enter a plus or minus to a quantity. Its most common use is in entering values for the equation, a method of flow conversion. On flow meters equipped with the optional modem, you can use this character as a dash when entering dialout numbers.

2.3 Programming Procedure

Programming a Model 4210 Flow Meter is simple; just press keys on the keypad to select items from a menu appearing on the display. To start programming, turn on the flow meter and wait for the display to settle. Then either press the Enter/Program Step key (generally referred to as Enter) or the Go To Program Step key.

The display will change to two lines of text; the first line describes the step you are programming and the second line shows the menu choices available. One of the menu items shown will be flashing. The flashing indicates that this choice is the current one held in memory. If you are satisfied with this choice, just press Enter, and the flow meter will move on to the next step.

If you want a different choice, you can move across the display with the left and right arrow keys. Each time you press the right arrow key, the flashing selection will move one position to the right. This will continue until the flashing cursor is over the last display.

You may notice an arrow pointing to the edge of the display. This means additional choices are available beyond what you can see. By continuing to press the right arrow key, you can view these unseen options. After reaching the furthest option, the arrow will move to the left side of the display, indicating that there are options to the left. These will be the options you started with. If you want to go back to one of them, use the left arrow key until the option you need reappears. When the desired selection is flashing, just press Enter. The display will then automatically advance to the next step of the program.

All of the program steps contain several “substeps” you must complete before you advance to the next step. Some steps, like Reset Totalizer contain only a few substeps. Some

steps will require the entry of a numeric value. Program these steps by using the number and decimal keys to enter the appropriate value.

Note that it is possible to program the flow meter in the shop, rather than at the job site, with the exception of step 3, Adjust Level/Parameters. To set level you must make an accurate measurement of the level in the flow stream and then enter that value. You can only do this at the job site.

If you are programming for the first time, press Enter, start with step 1, and go on from there. If the flow meter has been in use and you need to change only part of the program, you can use the Go To Program Step key to go directly to the program step you need.

If you change an entry and do not like it, you can make the display revert to the original entry by pressing Clear Entry. If you have already pressed Enter, however, the new value will be in memory.

To change it, press Exit Program. If you are in the middle of a program step with multiple substeps, the flow meter will display, "CHANGES HAVE BEEN MADE IN STEP; PRESS 0 TO CONTINUE OR 1 TO DISCARD." If you press 1, the display will return to normal and the last step you were working on will revert to its previous selection. (Any program step you completely change before exiting will remain changed.)

You can re-enter the program with either Enter or the Go To Program Step keys. If you become confused while programming, the best

suggestion is to press Exit Program and start over. Also remember that you can have the flow meter print a complete list of your program choices by exiting the program and by pressing the Print Program key as soon as the display returns to the normal operating condition, displaying level and total flow, etc. Following are the steps necessary to program the Model 4210:

1. Operating Mode
2. Flow Conversion
3. Adjust Level/Parameters
4. Reset Totalizer
5. Sampler Pacing
6. Sampler Enable
7. Alarm Dialout
8. Printer
9. Reports/History

2.4 Description of Program Steps

2.4.1 Step 1 - Operating Mode

Step 1, Operating Mode, determines how you set up the flow meter. In this step there are two choices, Program and Setup. Program advances you to step 2, and from there on you correlate the flow meter to the flow stream. Setup selects various basic “housekeeping” features for the flow meter. Here you determine the internal clock, site identification, measurement setup, hysteresis, report contents, operation of the

display backlight, and program lock. In Program you select the units of measure the flow meter will use for the display, calculations, and reports.

 **Note**

If you choose NOT MEASURED for any selection, the flow meter will make no further reference to that value or function for the rest of the program, and you will not be able to activate that process or function later on unless you reprogram step 1.

If there is a feature or option you need that does not appear on your display when the manual says it should, return to step 1 and make sure you have not inadvertently left it turned off in either the Program or Setup menus.

Note that selecting some features automatically excludes others. For example, selection of pH or D.O. excludes the other parameter, unless you use the YSI 600 Multi-Parameter Sonde, which measures pH, D.O., and conductivity at the same time.

This method keeps program size manageable and makes programming more efficient. By turning off unneeded features of the program early, you do not have to keep de-selecting those features over and over as you work through the program.

Consequently, you should choose carefully from the first step. We suggest you study the program first, then fill out the Programming Worksheets (in the back of the manual), and actually program the flow meter last, if you are unfamiliar with the unit.

2.4.2 Step 2 - Flow Conversion Type

Step 2, Flow Conversion Type, determines how the flow meter calculates flow rate and total flow. For the Model 4210, flow rate is calculated by knowing the measured level and (usually) the characteristics of a primary measuring device. A primary measuring device is a structure placed in a flow stream through which the entire stream must flow. These devices are made in a number of styles and sizes, but they all have one thing in common: For any type of primary measuring device there is a known relationship between the level in the flow stream ahead of the device and flow rate through the device. Consequently, after you measure level with the flow meter, it can calculate flow rate and total flow from the measured level, by consulting built-in look-up tables.

Detailed information about many commonly-used primary measuring devices is provided in the Teledyne Isco *Open Channel Flow Measurement Handbook*. This useful book provides formulas, flow rates at various levels, and values for maximum head, as well as much interesting descriptive material. A card is shipped with each flow meter entitling you to one copy of this book; additional copies are available from Teledyne Isco. If your installation uses a nonstandard primary device, you should consult the manufacturer of the device for flow rates at given levels. The flow meter will then calculate a flow conversion for

such a device on the basis of the manufacturers' data you enter as data points or an equation. In some instances, a nonstandard primary device could be supplied with a flow equation; you can enter that equation into the flow meter and the flow meter will calculate the flow rate from that equation.

Flow Calculations Without Primary

Devices – Note however, that it is not always necessary to have a primary measuring device. The Model 4210 Flow Meter can measure level and calculate flow without having any primary device installed in the flow stream. Sometimes the shape of the flow stream itself forms the primary device. The Manning formula uses the shape of a pipe or channel and its slope to calculate flow in open (non-pressurized) pipe situations. The conversion types available are WEIR/FLUME, MANNING, DATA POINTS, and EQUATION.

Use Weir/Flume flow conversion when your primary measuring device is a weir or a flume. A weir is a wall or dam across the flow stream. Water must rise to the point where it flows over the top of the wall. The measured level upstream behind the wall is used to calculate the flow rate. Flumes differ from weirs in that there is no wall or barrier, but instead a restriction, typically a sharp narrowing or change in the slope of the channel that restricts the flow.

Again, the measured level of the stream at some point ahead of the restriction is used by

the flow meter to calculate flow. In this flow conversion mode, the flow meter uses internal look-up tables for many common primary measuring devices.

An Equation is used when you have a non-standard primary device, or want to use different values from those programmed into the look-up tables of the flow meter. Equation flow conversion uses the standard flow equation:

$$Q = k_1H^{P_1} + k_2H^{P_2}$$

...where Q equals flow rate; k1 and k2 are constants; H is level (or head), and P1 and P2 are the powers to which the two H terms are raised. (Your equation may not have the second term, in which case you would enter 0 for the second constant, k2.) Most common primary devices are supported in the flow meter's software, so generally you will not need this option. But it is available for those needing to enter their own values, or for those who have a nonstandard primary device for which an equation can correlate level and flow.

Manning Flow Conversion uses the Manning formula to calculate flow in open or closed (nonpressurized) gravity-flow situations based on slope, diameter, and roughness of the pipe. The Manning formula is named for Robert Manning, a 19th-century Irish civil engineer. There is no primary measuring device as such. Instead the pipe, with considerations for its slope and internal roughness, serves as the primary device. The Model 4210 can calculate

flow in round pipes, rectangular, U-shaped, or trapezoidal channels based on this formula. Data Point Flow Conversion (DATA POINTS) calculates flow based on a set of user-entered data points for a flow stream. Data consist of correlated level and flow measurements for the stream. Like the Equation method of flow conversion, this flow conversion is most commonly used where the primary measuring device is nonstandard, but where tables of level and flow rate data are available from the device manufacturer. The Model 4210 has space for four sets of data with as many as fifty points per set. The flow meter then calculates flow from these data tables using a three-point interpolation.

2.4.3 Step 3 - Adjust Level, Parameters

Adjust Level, Parameters calibrates the measuring sensors that provide the flow meter with level and other information. In this step you set the level that the flow meter measures. First you measure, as accurately as possible, the level in the flow stream. Then you enter this value with the numeric keys. Accuracy is important. Remember that measured level provides the basis for calculated flow in the flow meter.

The flow meter also has an input port for measurements other than level. This is the Parameter Port. Here you can sense such variables in the flow stream as temperature, pH (the acidity or alkalinity of a solution) and

D.O. (dissolved oxygen) in the flow stream. You can have either pH with temperature, D.O. with temperature, or temperature alone. The port is not dedicated to a particular sensor, except through programming. You can change the sensor. For example, you can change from a pH probe to a D.O. sensor if you change the programming. Selection of one parameter will keep the other from showing up on the menus. Note, however, that it is possible to measure several different stream conditions (including pH and D.O.) at the same time with the YSI 600 Sonde.

The YSI 600 Sonde – The YSI 600 Sonde is a multi-purpose, water quality measurement device. It is intended for use in research, assessment, and regulatory compliance. The sonde attaches to the modified Rain Gauge connector on the Model 4210. Flow meters having only a 4-pin rain gauge connector will not support the YSI Sonde. If you wish to upgrade your flow meter to use this system, contact the factory.

Note that you can have both the YSI 600 Sonde and the Rain Gauge connected to the flow meter at the same time by using a special Y-connect cable.

The YSI 600 can measure the following water qualities: dissolved oxygen (D.O.), conductivity, temperature, and pH. Conductivity measurements made by the sonde can be used to calculate specific conductivity, salinity, and total dissolved solids. A brief description and

specifications for the YSI 600 are printed in Section 4 in the instruction manual (Accessories). You may also contact the factory or your Teledyne Isco representative. More information on the sonde is found in the YSI 600 Manual, shipped with each YSI 600 Sonde.

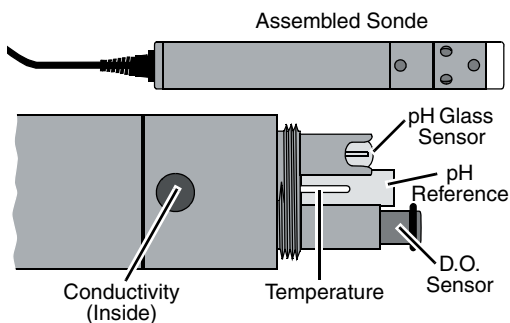

Figure 2-1 YSI 600 Sonde

2.4.4 Step 4 - Reset Totalizer

In this step you decide whether you want to reset the flow meter's internal flow totalizers. If the installation is permanent you generally won't reset the totalizer. If you are using the flow meter as a portable recording unit and are moving it from one site to another, you would generally reset the totalizer between sites.

2.4.5 Step 5 - Sampler Pacing

It is common to use a flow meter with an Isco Automatic Wastewater Sampler. Typically the flow meter signals the sampler to take a sample after a certain volume has passed. It might also occur after a certain condition or set of conditions has either changed or been met. This step allows you to determine that control.

There are several possible options—DISABLE, CONDITIONAL, VOLUME, and FLOWLINK. DISABLE will keep the sampler from receiving a flow pulse from the flow meter. VOLUME allows the flow meter to signal the sampler whenever a specific flow volume has passed by. FLOWLINK (this option will only appear if you are using Flowlink software), allows the sampler to be signalled from the flow meter as a result of conditions determined by Flowlink. Flowlink is Teledyne Isco's proprietary data acquisition and management software.

Flowlink works with personal computers, modems, and laptop computers to monitor flow meters from a distance. Consult the factory for more details about Flowlink.

VOLUME causes the flow meter to pace the sampler after a specific volume has passed through the flow stream.

CONDITIONAL allows pacing of the sampler by the flow meter when a condition has been met, or has changed. Among these conditions are changes in level, flow rate, temperature, rainfall, (if you are using the rain gauge), dissolved oxygen, or pH. You can also use a

combination of conditions. D.O. (dissolved oxygen), or pH, or if you are using the YSI 600 sonde, you can select multiple conditions from its sensors.

 **Note**

If you choose **CONDITIONAL** for sampler pacing and it doesn't seem to work properly for you, read the section on hysteresis (page 3-8). Then check the hysteresis setpoints for your conditions. (The defaults are all zero.)

You must have the appropriate sensors attached to the flow meter to measure temperature, D.O., pH, conductivity, etc.; the flow meter cannot do this by itself, nor does it occur automatically.

2.4.6 Step 6 - Sampler Enable

Sampler Enable means that in a combination flow meter/sampler pair, the flow meter controls the sampler's ability to run its own program. The difference between step 5, sampler pacing, and step 6, sampler enable is that in sampler pacing, the flow meter merely sends flow pulses to the sampler from time to time. The sampler counts these flow pulses to determine when to take a sample (according to its own programming).

With sampler pacing, the sampler is always enabled. With sampler enabling, the flow meter can actually stop operation of the sampler. The sampler is still set up to run its own program, but the inhibit/enable line from the flow meter will determine when and whether the sampler

runs its program. This feature is useful for storm water runoff monitoring applications, where it may be necessary for the flow meter/sampler pair to have to wait a long time between storm intervals.

Again, changing or meeting a condition or set of conditions triggers the enabling. The conditions that can be used for sampler enabling are similar to those used for sampler pacing: level, flow rate, rainfall, temperature, dissolved oxygen, pH, or a combination of these conditions. The YSI 600 Sonde provides several measurements at the same time. (You must have the appropriate sensors for rainfall, temperature, D.O., pH and the YSI outputs.)

2.4.7 Step 7 - Alarm Dialout Mode

This feature allows you to program a Model 4210 Flow Meter to signal a remote location through a telephone line. This feature is useful for transmitting alarm conditions or other essential information to a remote location.

 Note

You must have the optional modem installed to make use of this program step. The menus will not even appear unless the flow meter has a modem installed.

The Alarm Dialout feature is useful if you need to signal a remote location when there is a change of condition in the flow stream that could constitute an alarm. You can program as many as five different eighteen-digit telephone numbers into the flow meter in decreasing

order of importance. The modem is capable of speech.

DISABLE inhibits this function altogether. CONDITIONAL lets you program the flow meter to signal these alarms for a variety of reasons. You can use rainfall, time, level, flow rate, dissolved oxygen, pH, rate-of-change, a combination of conditions, or define the operation through Flowlink software from another computer. STORM lets you set the alarm through a combination of rainfall and time. You can also program the interval between calls and set up the system to reset the alarm condition by dialing back from the remote telephone.

2.4.8 Step 8 - Printer

All Model 4210 Flow Meters have a built-in printer. The printer is more than just a printer, as it is capable of plotting linear data along with printing alphanumeric (letters and numbers) messages. In this step you set the speed for the chart to advance, from $\frac{1}{2}$ " to 4" per hour.

Chart speed is set according to the amount of resolution you want to see on the chart. If there is a great deal of activity on the chart, you would generally choose a faster speed so the marks are more "spread out" and are easier to interpret. If there is little activity on the chart and you want the flow meter to run for long periods without having to change the roll, you would pick a slower speed.

The flow meter is capable of plotting three separate data lines on the chart in addition to the alphanumeric messages. These lines may indicate such things as level, flow rate, pH, dissolved oxygen, or temperature. Note that you must have the appropriate sensors for pH, D.O., and temperature to take advantage of the availability of these plots.

The printer is capable of plotting over-ranges for the data lines it plots. You can tell when the printer is in over-range if a data line goes off the chart on the right side and then immediately starts over again plotting on the left side.

2.4.9 Step 9 - Reports/History

This step lets you program the flow meter to print regular reports on the internal printer. The reports the flow meter prints are a summary of activity recorded over time. Typically included are such items as maximum and minimum flow rates, the time they were reached, sample records, etc.

The flow meter lets you create two separate reports, and define what appears on them to a great extent. Note that the contents of the reports are defined in Setup in step 1. Step 9 merely lets you turn them off and on and set the timing. You can define the start time, the interval between reports and other aspects of the report.

History provides a record of changes made to the flow meter's program or operation events.

As many as 50 changes can be stored in the flow meter's memory at a time. The memory can store up to 50 history items and 200 sample events at a time.

4210 Ultrasonic Flow Meter

Section 3 *Programming*

Following are the program screens as they appear on the display of a Model 4210 Flow Meter. Explanations for most of the screens will be provided.

<input checked="" type="checkbox"/> <i>Important</i>

Some items that appear in the following menus will have parentheses (...) around them. This means that the item may or may not appear on your flow meter. Choices made early in the program can make some options unavailable later.

An example of this is the pH/D.O. option. Selection of one in step 1 will keep the other from appearing in all subsequent menus. Some diagnostic and error screens are covered in Section 5 of the Model 4210 Instruction Manual.

3.1 Step 1 - Operating Mode

Turn on the flow meter. Wait for the display to settle. Then press the Enter/Program Step

(Enter) key. The following will appear. (Step 1)
If the following menu does not appear, press
Exit Program, then Go To Program Step, then
press 1.

```
SELECT OPTION
• PROGRAM • • SETUP •
```

PROGRAM is always the default. If you press
Enter, the display will automatically advance to
the next display, which will ask you to select
units of measurement. If you select SETUP, the
following will appear:

```
SETUP OPTIONS: 'EXIT' TO QUIT
• SET CLOCK • • SITE ID • • MEASUREMENT SETUP •
```

If you press the right arrow key, the following
options will appear on the display:

```
SETUP OPTIONS: 'EXIT' TO QUIT
• STATUS ENABLE/ALARM HYSTERESIS •
```

Then:

```
SETUP OPTIONS: 'EXIT' TO QUIT
• OPTIONAL OUTPUTS • • REPORT SETUP •
```

And:

```
SETUP OPTIONS: 'EXIT' TO QUIT
• LCD BACKLIGHT • • (LANGUAGE) • • PROGRAM LOCK •
```

Finally:

```
SETUP OPTIONS: 'EXIT' TO QUIT
• (LANGUAGE) • • PROGRAM LOCK • • PROGRAM •
```

LANGUAGE may not appear on your machine.
This is intended primarily for export models, as

they are programmed in different languages. Domestic models contain only English.

If you select SET CLOCK, the following will appear:

YEAR	MONTH	DAY	HOUR	MIN
XXXX	XX	XX	XX	XX

Enter the year (four digits), the month (01-12), the day (01-31), the hour (01-24), and the minute (01-59).

If you select SITE ID, the following will appear:

SITE ID: XXX

You can select any suitable three-digit number for the site identification. If you select MEASUREMENT SETUP, the following will appear. You will have to use the right arrow key to bring all the options on screen:

MEASUREMENT SETUP
• LEVEL READING INTERVAL • • DO/PH READING INT-

MEASUREMENT SETUP
• DO/PH READING INTERVAL • • VARIABLE BLANKING •

LEVEL READING INTERVAL refers to how often the flow meter takes a level reading. **LEVEL** refers to the level in the flow stream. **DO/PH READING INTERVAL** refers to the measurement of aspects of the flow stream other than amount. The Model 4210 supports measurement of three different characteristics: temperature, pH (the relative acidity or

alkalinity of a solution), and D.O., dissolved oxygen.

MEASUREMENT SETUP

• VARIABLE BLANKING • • YSI 600 READING INTERVAL •

VARIABLE BLANKING refers to the ability of the flow meter to ignore certain measurements of the ultrasonic transducer to reduce the possibility of error. **YSI 600 READING INTERVAL** refers to the frequency of measurements made by the YSI 600 Sonde. If you select **LEVEL READING INTERVAL**, the following will appear:

LEVEL READING INTERVAL

•CONTINUOUS••15 SEC••30 SEC••1 MIN••2 MIN••5 MIN•

The **LEVEL READING INTERVAL** option is a way to conserve power in battery-powered installations. If your installation is AC-powered, you can simply select **CONTINUOUS**.

 **Note**

The Model 4210 expends considerable power generating the ultrasonic pulses.

Select the longest acceptable interval between readings, if you are operating on battery power. If you need a faster response time, select one of the shorter intervals. If you are operating on battery power, you may have to seek a compromise between short reading intervals and battery life expectancy.

If you select VARIABLE BLANKING, the following will appear:

VARIABLE BLANKING DISTANCE = XX.XX FT (or meters)
--

You can determine this distance approximately by measuring from the face of the (installed) ultrasonic level sensor to the surfaces of the channel just above the maximum expected liquid level. This value tells the flow meter to ignore any echo reflected from this distance or less.

The purpose of this selection is to let you fine-tune the reflection cone beneath the level sensor. If the level sensor is mounted too high above the flow stream, there is a good chance echoes will be reflected from the channel walls, tops, sides, or other solid surfaces, having nothing to do with the actual liquid level. Proper selection of a value here will ensure that echoes selected by the flow meter as valid will only come from the surface of the flow stream, not the walls of the channel.

If you select DO/PH READING INTERVAL, the following will appear:

DO/PH READING INTERVAL •CONTINUOUS•15 SEC•30 SEC•1 MIN•2 MIN•5 MIN•
--

Again, this selection is offered as a way to save battery power. After selecting the appropriate interval, press Enter.

This time select **YSI 600 READING INTERVAL** from the menu. The following display will appear:

YSI 600 READING INTERVAL •CONTINUOUS•15 SEC•30 SEC•1 MIN•2 MIN•5 MIN•
--

YSI 600 READING INTERVAL refers to the YSI 600 Sonde, The flow meter can measure several different aspects of the flow stream at the same time, including pH, D.O., and temperature, plus conductivity.

 Note

If you are using the Teledyne Isco D.O. sensor or are sensing D.O. with the YSI 600 Sonde, select as long a measurement interval as is practical for your application. The D.O. sensor is turned off between measurement intervals and this turned-off period prolongs the life of the sensor.

The Setup menu will reappear. This time select **STATUS** from the Setup menu. Press Enter. The following will appear:

MODEL 4210 HW REV: XXXXXX SW REV X.XX ID XXXXXXXXXXXX
--

- HW REV refers to the hardware revision number.
- SW REV refers to the software revision number.
- ID is an internal identification number for the flow meter.

If you press Enter again, you will see the following display:

SIGNAL STRENGTH X%

The flow meter will read continuously when this screen is displayed. This value indicates the functioning of the ultrasonic sensor. This display exists primarily as a diagnostic tool for telephone troubleshooting. There is no “magic” number you should expect to see. If the flow meter is displaying valid level/flow readings, you do not need to worry much about the numbers. The numbers become important when you cannot get valid level/flow readings. If there is a number greater than zero displayed for signal strength, the following is generally indicated:

1 = a very weak return signal

100 = a very strong return signal.

Numbers from 10 to 90 are normal, and numbers of 50 to 90 are typical for sewers.

The important thing to remember when interpreting this number is consistency—Is the number fairly consistent from one reading to the next?

Generally speaking, the higher the number the better. Typical values will range from 30 to 100. Again, this number is important only:

- If you doubt the accuracy of the level reading, or

- If the value itself is unstable from one reading interval to the next.

Press Enter again; the flow meter will display the system voltage:

SUPPLY VOLTAGE: XX.X

This value should be from 10.5 to 13.5 (volts DC). Note that if you do not press Enter after the first diagnostic menu appears, the flow meter will automatically advance the display through the next two screens and finally revert to the Setup menu after a short timeout.

YSI SOFTWARE REV: XX.X

Return to the Setup menu if the unit has not already done so. This time select **ENABLE/ALARM HYSTERESIS** from the menu. Press Enter. The following will appear:

LEVEL ENABLE/ALARM
HYSTERESIS X.XXX FT (or meters)

The **HYSTERESIS** menu lets you set the range over which the level (or other condition) can vary before the flow meter responds to the change.

In the **PROGRAM** section of the software there are several steps that require a change in a condition to make the flow meter carry out certain actions. For example, step 6 programs the flow meter to enable (activate) a sampler. In that step, you select a condition (or set of conditions) that must occur before the sampler

is enabled. You enter a value (level is an example) that must be met before the enabling occurs. But what if this value is met and then falls away? It is possible for a condition to vary rapidly over a narrow range. Without hysteresis, the flow meter will turn the sampler off and on repeatedly, causing a condition known as chattering, that would result in very erratic operation of the sampler.

With hysteresis, you can enter a value that will keep the flow meter from responding to insignificant changes in the enabling condition. You should select a value for hysteresis that is narrow enough to allow the flow meter to respond to any serious change, but broad enough to ignore minor changes that could cause chattering. Press Enter and the following will appear:

FLOW RATE ENABLE/ALARM HYSTERESIS X.XXX CFS (or other units of measure)
--

The next several menus may or may not appear, depending on selections you make in Program. They concern alarm/enable hysteresis set points for parameter sensing—temperature, pH, and D.O.

If you want to set hysteresis for any of these items, you should enable them when you work through the program section, then re-enter the Setup section (Hysteresis) and they will appear. Note that you can have temperature alone, or temperature with either pH or D.O. You must have temperature with either pH or D.O.

Note

You cannot have pH and D.O. at the same time, and selection of one will prevent the other from appearing on the menus later.

The following will appear if you are measuring temperature:

TEMPERATURE ENABLE/ALARM
HYSTERESIS XX.XXX DEG F (or DEG. C)

The following will appear if you are measuring pH:

pH ENABLE/ALARM
HYSTERESIS X.XXX pH

The following will appear if you are measuring D.O.:

DO ENABLE/ALARM
HYSTERESIS X.XXX PPM

(or mg/l depending on units selected in Program.)

A set of menus similar to those shown above for pH, D.O., and temperature will then appear for the YSI 600 Sonde, if you have selected it. You can set hysteresis for YSI-pH, YSI-D.O., YSI-Conductivity, and YSI-temperature, if these parameters have been turned on in previous program selections.

After all the HYSTERESIS menus have been set, press Enter. The display will return to the

Setup menu. This time select **OPTIONAL OUTPUTS** with the arrow key. Press Enter.

OPTIONAL OUTPUTS

• ANALOG OUTPUT • • SERIAL OUTPUT • • ALARM BOX •

ALARM BOX refers to an external accessory used to signal alarms from flow meter measurements. The High-Low Alarm Box is a Teledyne Isco product that operates control relays to signal alarms when flow rate rises above or falls below a preset value. You can set both alarm values from 1 to 99% of the controlling condition. See Section 4 in the instruction manual for more information about the Alarm Box. Note that choice of **SERIAL OUTPUT** will eliminate **ALARM BOX** as an option. Likewise, choice of **ALARM BOX** will eliminate **SERIAL OUTPUT** as an option.

If you select any of these **OPTIONAL OUTPUTS**, the flow meter will request that you turn them on or off. If you are running on battery, select **OFF** for all unused outputs.

ANALOG OUTPUT refers to the flow meter's capability of managing associated equipment through a 4–20 mA current loop. The 4–20 mA current loop is a common method used to control industrial processes that are variable (rather than just fully off or on). At the lower value (4 mA) the control is turned off (0%); at 20 mA the control is completely turned on (100%). In between, rates range from 1 to 99%. A typical application is a chlorinator, which must vary in application of the chlorine gas as

the amount of water passing through the system increases or decreases. Current ranges other than 4–20 mA are also in use, although they are less common than 4–20 mA. Examples are 0–20 mA (supported by the flow meter on the internal card only) and for longer current loops, 10–50 mA (not supported by the flow meter).

Teledyne Isco offers two different arrangements for the 4–20 mA control circuit. You can have either or both with the same flow meter. One arrangement requires the use of an external accessory, the 4–20 mA Output Interface (see Section 4). This module connects to the flow meter and a source of AC power and contains the circuitry necessary to create the 4–20 mA current loop. This accessory connects to the flow meter through the Interrogator connector. The other 4–20 mA option is a board installed inside the flow meter that contains circuitry for up to three isolated 4–20 mA current loops. If you use both the external converter and the internal board, you can have a total of four current loops controlled by the same flow meter. The internal current loops are brought out to a 6-pin M/S connector in the slot where the Modem connector is usually mounted. Additional information for the internal analog output board, including specifications for the loops, is found in Section 4.



CAUTION

Each 4–20 mA output represents a constant drain on the flow meter of at least 16 mA whether activated or not. While 4–20 mA applications are generally made in installations with commercial power available, we suggest the following for those who have a 4–20 mA output in a battery-powered installation. Use with battery powered flow meters only:

1. If the battery is continuously on charge (for example with a Solar Panel Battery Charger)
2. If the battery is very large, such as a deep-cycle or marine type battery, or an Isco 45 Ampere-hour lead-acid battery.
3. Use only one 4–20 mA output.
4. Keep in mind that programming choices also affect power consumption. Use “minimum” settings on the flow meter wherever possible.

Even with these circumstances, you may expect significantly shorter charge life from your battery. To determine the effect of this extra current draw on battery life, please refer to the section *How to Make Battery Calculations*, at the end of Section 1.

The following menus determine the behavior of the 4–20 mA current outputs. If you select **ANALOG OUTPUT** (another term for the 4–20 mA Output) and the flow meter is equipped with the optional internal board or the 4–20 mA external accessory has been turned on, **RANGE**, **SMOOTHING**, and **MANUAL**

CONTROL will appear: MANUAL CONTROL will appear if you continue moving to the right.

ANALOG OUTPUT

• EXTERNAL 4-20 mA • • (RANGE) • • (SMOOTHING) •

 **Note**

If you know for certain that you have the proper installed hardware for internal 4–20 mA outputs and you do not see the proper displays, return to the “normal” flow meter display and press 4 - 2 - 0.

 **CAUTION**

If you do not have the proper hardware installed and you press 4 - 2 - 0 and the number of analog outputs is not zero, the external 4–20 mA converter will not work properly. If this occurs return to the 4 - 2 - 0 option, and at the prompt, enter 0 for the number of outputs activated. This will restore the external 4–20 mA converter capability.

“RANGE” will appear with the ANALOG OUTPUT menu if the optional internal 4–20 mA converter is present in the flow meter. If you select RANGE, the following will appear:

OUTPUT RANGE

• 0 - 20 mA • • 4 - 20 mA •

This menu lets you select the current value for zero-percent (baseline) compatible with your equipment (internal 4–20 mA board only).

If you select SMOOTHING from the ANALOG OUTPUT menu the following will appear:

SMOOTHING

• NONE • • 15 SEC • • 30 SEC • • 1 MIN •

The SMOOTHING option lets you stabilize operation of the outputs by preventing a rapid reaction to sudden sharp changes in the condition being monitored that quickly return to normal (transients). Selection of a smoothing interval will prevent the equipment controlled by the 4–20 mA loop from reacting too quickly, too much, or operating erratically. A low-pass filter algorithm is incorporated in the software. If you select the MANUAL CONTROL option from the ANALOG OUTPUT menu the following will appear:

MANUAL CONTROL (OUTPUT 0 = EXTERNAL)

OUTPUT 0 = 0.0 MA

This option lets you control the operation of a 4–20 mA loop to check the operation of equipment controlled by the loop at any level from 0 to 100%. After connecting a 4–20 mA output to a controlled device, you can program the flow meter to put a specified current on a specific analog output. If you are using the external 4–20 mA converter, the Analog Output number will be zero.

 **Note**

Selecting the MANUAL CONTROL option and programming any one of the ports will prevent the values transmitted by the other active 4–20 mA ports

from being updated until the test is completed. The other ports will continue to transmit whatever value they held at the start of the test. Exiting from the MANUAL CONTROL menu at the end of the test will return all active 4–20 mA ports to normal operation.

Programming for the conditions and values that determine the operation of the 4–20 mA loop (or loops) is done in step 2.

Returning to the OPTIONAL OUTPUTS menu, you will see the SERIAL OUTPUT option. This feature lets the flow meter transmit the most recent values for all currently enabled ports as ASCII text. You can then write a simple program to retrieve this data periodically, or you can do it interactively using a terminal program.

 **Note**

The information in the following section is provided for those who can write their own software programs to process the data transmitted from the Serial Output port. Special cables may be required. Contact Teledyne Isco Technical Support for more information.

Command Line – (Use the INTERROGATOR connector.) The lines of text contain the port values for each port that is turned on.

The DATA command will use a special command response protocol. The following table provides the ASCII codes for port types and standard units of measure.

Table 3-1 ASCII OUTPUT CODES^a

Code	Parameter	Units
DE	Description	String (enclosed in quotes)
ID	Unit specific identifier	Unsigned long
MO	Model	String (enclosed in quotes)
TI	Time since 1900	Days
BV	Battery Voltage	Volts
LE	Level	Meters
LSI	Level Signal Strength	0 - 100%
VE	Velocity	Meters per second
VSI	Velocity Signal Strength	0 - 100%
VSP	Velocity Spectrum Strength	0 - 100%
FL	Flow	Cubic meters per second
VO	Volume	Cubic meters
FV	Forward volume	Cubic meters
RV	Reverse volume	Cubic meters
SV	Sampler Enabled Volume	Cubic Meters
RA	Rain (rolls over every 255 tips)	Tips

Table 3-1 ASCII OUTPUT CODES^a
(Continued)

Code	Parameter	Units
CR	Current day's rain (tips since midnight)	Tips
PR	Previous day's rain (tips since midnight)	Tips
PH	pH	pH units
DO	Dissolved Oxygen	Milligrams per liter
TE	Temperature	Degrees Celsius
YPH	YSI 600 pH	pH units
YDO	YSI Dissolved Oxygen	Milligrams per liters
YCO	YSI 600 Conductivity	Millisiemens per centimeter
YSP	YSI 600 Specific Conductance	Millisiemens per centimeter
YSA	YSI 600 Salinity	Parts per thousand
YTD	YSI 600 Total Dissolved Solids	Milligrams per liter
YTE	YSI 600 Temperature	Degrees Celsius
YSP	YSI 600 Specific Conductance	Millisiemens per centimeter
YCO	YSI 600 Conductance	Millisiemens per centimeter

**Table 3-1 ASCII OUTPUT CODES^a
(Continued)**

Code	Parameter	Units
YSA	YSI 600 Total Salinity	Parts per thousand
YTD	YSI 600 Total Dissolved Solids	Milligrams per liter
YTE	YSI 600 Sonde Temperature	Degrees Celsius
SS	Sampler Enable Status	Logical
B?	Bottle Number and Time	Days
CS	Checksum (does not include the check sum, carriage return, and line feed)	Unsigned long

a. The output string for a given flow meter will have values only for those parameters it is currently measuring. The order of the fields in this table is subject to change. Additional data types may be inserted anywhere in the list. Parsing routines for this output string should search by type identifier instead of depending on the position in the string. If an active port has an error flag set, the serial output will insert ERROR for the value.

You can enter the command line by connecting the interrogator cable with the interrogator sense line shorted to ground. Then send a series of '?' (question marks) until the flow meter

transmits the unit's banner and prompt. The number of question marks necessary is a function of the baud rate auto detection. At the prompt, enter DATA<CR> and the flow meter will respond with the appropriate ASCII output string. You can send the DATA command as often as you want. Type 'Q' to leave the command response interface.

In addition to the port values, the data includes the flow meter's current time, the bottle number and time stamp of the three most recent sample events, the previous day's rainfall total (midnight to midnight), the current day's rainfall total since midnight, and a rainfall tips counter that rolls over every 255 tips. (See Rain Gauge.) The port values appear in a comma-separated values format. Each data field is preceded by a two or three-character type identifier. The table lists the type identifiers. Note that the flow meter's current time and the sample event time stamp appear as a number in standard spreadsheet format (days since 1900). The supported baud rates are 9600, 4800, 2400, and 1200 (no parity, eight bits and one stop bit).

Periodic Output: (Use a special RAIN GAUGE connector cable—contact the factory for assistance.) Note that the periodic output will terminate during phone connection and when the interrogator cable is connected.



CAUTION

It is important to use CHECKSUM if you plan to use internal modems or the interrogator. The UART is shared with these devices.

If you select SERIAL OUTPUT from the OPTIONAL OUTPUTS menu, the following display will appear:

```
PERIODIC SERIAL OUTPUT
• ON • • OFF
```

Selection of OFF from this menu will disable this feature, and there will be no further references to it.

The Serial Output data appears on the Interrogator connector of the flow meter. You should not use a standard interrogator cable for this application, as the sense line in the standard cable is shorted to ground.

Selection of ON from this menu will enable the feature and cause the following display to appear:

```
SELECT BAUD RATE (N81)
• 9600 • • 4800 • • 2400 • • 1200 •
```

After you select the appropriate baud rate, the program will advance to the following menu:

```
SERIAL OUTPUT INTERVAL
• 15 SEC • • 1 MIN • • 5 MIN • • 15 MIN •
```

This menu lets you select how often the flow meter transmits the ASCII text string.

Following is an example of a string showing all options: (Note that five lines are shown here; this is due to the confines of the text column. In actual practice, there are no carriage returns in the text string.)

```
DE, "Theresa Street", 4210 ALPHA 4, ID, 0721577657,  
MO, 4210, TI, 35317.343715, BV, 12.3, LE, 0.1000, VE, 0.12  
25, FL, 0.001555, VO, 2.199325, FV, 2.199325, RV, 0.00000  
0, SV, 2.195539, SS, 1, B0, 35317.307384, B0, 35317.26990  
7, B0, 35317.232593, CS, 10819
```

If you select any of these outputs, the flow meter will request that you turn them on or off. If you are running on battery and do not need these options, select OFF. Otherwise, select ON. After the OPTIONAL OUTPUTS menus have been set, press Enter. The display will return to the SETUP menu.

This time, select REPORT SETUP with the arrow key. Press Enter:

REPORT SETUP • REPORT A • • REPORT B •

This step lets you determine the contents of the reports generated by the flow meter. The flow meter's report generator is capable of creating two different reports (A and B) that can be identical or quite different. The reason for two reports is to allow the summary of events occurring over different time periods. For example you might generate report "A" weekly, and report "B" monthly. At this point, we are only interested in selecting the items the flow

meter will include in each report. Press Enter and the following will appear:

REPORT SETUP

• FLOW • • DO/PH • • YSI 600 • • SAMPLE HISTORY •

FLOW METER HISTORY is just off the screen, to the right. If you select FLOW and press Enter, the following will appear:

LEVEL IN REPORT

• YES • • NO •

Select YES if you want LEVEL to appear in the report, then press Enter. The following will appear:

FLOW RATE IN REPORT

• YES • • NO •

Select YES if you want FLOW RATE to appear in the report, then press Enter again. Then:

RAINFALL IN REPORT

• YES • • NO •

Select YES if you want RAINFALL to appear in the report. Note that you must have a rain gauge connected to the flow meter to sense rainfall occurrence. Press Enter. The following will appear:

REPORT SETUP

• FLOW • • DO/PH • • YSI 600 • • SAMPLE HISTORY •

FLOW METER HISTORY is just off the screen to the right.

This time select DO/PH. Press Enter. The following will appear:

```
PH OR DO IN REPORT
• YES • • NO •
```

Select YES if you want DO/PH to appear in the report. Note that you must have the appropriate sensor connected to the flow meter. It is capable of sensing temperature, pH and temperature, and D.O. (dissolved oxygen) and temperature. Press Enter. The following will appear:

```
TEMPERATURE IN REPORT
• YES • • NO •
```

Select yes if you want TEMPERATURE to appear in the report. Press Enter again and the display will return to the REPORT SETUP menu:

```
REPORT SETUP
• FLOW • • DO/PH • • YSI 600 • • SAMPLE HISTORY •
```

FLOW METER HISTORY is just off the screen. This time select YSI 600. The following display will appear:

```
YSI DATA IN REPORT
• YES • • NO •
```

Press Enter again and the display will return to the REPORT SETUP menu.

```
REPORT SETUP
• FLOW • • DO/PH • • YSI 600 • • SAMPLE HISTORY •
```

Now, select **SAMPLE HISTORY**. Press **Enter**.
The following will appear:

```
SAMPLE HISTORY IN REPORT
• YES • • NO •
```

Select **YES** if you want **SAMPLE HISTORY** to appear in the report. Press **Enter** again and the display will return to the **REPORT SETUP** menu:

```
REPORT SETUP
• DO/PH • • SAMPLE HISTORY • • FLOW METER HISTORY •
```

Select **FLOW METER HISTORY**. Press **Enter**.
The following will appear:

```
FLOW METER HISTORY IN REPORT
• YES • • NO •
```

Select **yes** if you want **HISTORY** to appear in the report. **HISTORY** is a list of the changes that have been made to the flow meter's program.

Press **Exit** to leave the program. Then press **Enter** and reselect **SETUP**. The Setup menu will reappear:

```
SETUP OPTIONS: 'EXIT' TO QUIT
• STATUS • • REPORT SETUP • • LCD BACKLIGHT •
```

SET CLOCK, **SITE ID**, **MEASUREMENT SETUP**, **PROGRAM LOCK**, **PROGRAM** are off-screen and can be reached with the arrow keys.

Select LCD BACKLIGHT with the arrow key. Press Enter. The following will appear:

LCD BACKLIGHT MODE • KEYPRESS TIMEOUT • • CONTINUOUS • • OFF •

KEYPRESS TIMEOUT will cause the backlight to be turned on whenever you press a key on the keypad (other than On and Off). An internal timer is started that will keep the backlight on for approximately two minutes after you press a key. Each time you press a key, the timer is restarted, so the backlight won't go off as long as you continue to program, with keystrokes coming less than two minutes apart. At the end of programming, the backlight will go out, and will stay out until you start to program again.

This feature is designed to conserve battery power by de-energizing the backlight when it is not needed. The backlight is still available if it is necessary to program in a dark environment, such as a manhole. We recommend using this selection if the flow meter is battery-powered, but installed in an environment where the lighting is poor.

CONTINUOUS will cause the backlight to be lit continuously. Where the flow meter is powered by an AC power supply, battery life considerations do not intervene. If the backlight makes the display easier to read, use it. Do not use CONTINUOUS in any installation that is battery-powered, as it will cause rapid discharge of the battery.

OFF keeps the backlight feature turned off under all circumstances. Select this option for maximum battery life in installations where there is sufficient ambient light to read the display without the backlight feature. Press Enter. The SETUP menu will return. This time move the flashing cursor from LCD BACKLIGHT to LANGUAGE.

When LANGUAGE appears on your display, you may select an alternate language to program the flow meter. The other language depends on how the flow meter was ordered. The following display will appear:

LANGUAGE

• ENGLISH • • (second language, as ordered) •

Select the language appropriate for your application. The menus and the printed reports will appear in the selected language. Press Enter. The SETUP menu will reappear. This time select PROGRAM LOCK from the menu. Press Enter:

PROGRAM LOCK

• ON • • OFF •

PROGRAM LOCK keeps the program from being changed. Select OFF while you are programming, and then go back and select ON if you need to lock the program. At that, we suggest using the lock only if there are compelling security reasons. Further changes will require entry of the password, which is the model number for whatever flow meter you are using, for example 4210 for the Model 4210. If

you select ON, there is a time-out before the lock engages. If you continue to work through the rest of the program, the lock will not engage until you are done. But if you stop programming longer than two minutes, the lock will engage, and you will not be able to make any further program changes.

Press Enter and the SETUP menu will reappear:

SELECT OPTION • PROGRAM • • SETUP •
--

PROGRAM will be flashing. (Note that PROGRAM is always the default choice. That is because you are more likely to need to make changes in the PROGRAM section of the software than in the SETUP section.)

<input checked="" type="checkbox"/> Note

If you choose NOT MEASURED for any selection, the flow meter will make no further reference to that function for the rest of the program, and you will be unable to activate that function later. If there is a feature you need that does not appear when the manual says it should, return to step 1 and make sure you have not accidentally left it turned off.

If you program a parameter value as a condition for sampler enabling, pacing, dialout, etc., and then turn that parameter sensor off, the flow meter will also remove that condition from the program.

Consider all aspects of your program before you make any changes!

Press Enter. The following will appear:

UNITS OF LEVEL MEASUREMENT

• FT • • IN • • M • • MM • • NOT MEASURED •

Selection of feet, inches, meters or mm depends on your situation. You would select NOT MEASURED if you were using the flow meter for some other form of sensing only, such as pH, or temperature. Press Enter. The following will appear. You will have to press the right arrow key several times to see all of the options displayed below:

FLOW RATE UNITS OF MEASURE

GPS • • GPM • • GPH • • MGD • • CFS • • CFM • • CF-

Pressing the right arrow key several times will move other units onto the display:

FLOW RATE UNITS OF MEASURE

CFH• •CFD• •LPS• •M3S• •M3M• •M3H• •M3D• •AFD•

NOT MEASURED will also appear if you keep moving with the right arrow key. This step establishes the units of measure the flow meter will use in all subsequent displays and calculations.

GPS = gallons per second

GPM = gallons per minute

GPH = gallons per hour

MGD = millions of gallons per day

CFS = cubic feet per second

CFM = cubic feet per minute

CFH = cubic feet per hour

CFD = cubic feet per day

LPS = liters per second

M3S = cubic meters per second
M3M = cubic meters per minute
M3H = cubic meters per hour
M3D = cubic meters per day
AFD = acre-feet per day.

TOTALIZED VOLUME UNITS

• GAL • • MGAL • • CF • • L • • M3 • • AF •

This step determines the units value the flow meter will use to record the totalized flow volume that passes by.

GAL = gallons
MGAL = millions of gallons
CF = cubic feet
L = liters
M3 = cubic meters
AF = acre-feet.

For the next several substeps you must have the appropriate sensor attached to the flow meter's Parameter Port or Rain Gauge Port (for the Rain Gauge or YSI 600 Sonde) to take advantage of the capabilities. You can only have D.O./temperature, pH/temperature or temperature alone on a given flow meter, unless you use the YSI 600 Sonde. The YSI 600 Sonde provides multiple outputs simultaneously. You can use the Rain Gauge with the YSI 600 sonde if you use a Y-connect cable.

Remember that programming for one type of sensor will prevent any references to the other in later program steps. All sensors but the rain

gauge are mounted fully submerged in the flow stream.

The pH and D.O. probes must be kept constantly wet or they can be damaged.

 **Note**

The pH or D.O. probes do not attach directly to the flow meter, as their output signals are quite low. You must also have the appropriate amplifier box connected between the probes and the flow meter.

Their use in streams with intermittent flow (such as storm drainage) is not recommended. Note that even in normal use, the pH probe becomes contaminated over time and exposure, and will eventually need replacement in any case.

RAIN GAUGE

• INCHES • • MM • • NOT MEASURED •

You must have an Isco Model 674 Rain Gauge (or approved equivalent) connected to the flow meter through the Rain Gauge Port to sense rainfall. MM = millimeters. The rain gauge is factory-calibrated. See Section 4 (Accessories) in the instruction manual for more information about the rain gauge. If you are not using a rain gauge, you would select NOT MEASURED for this step.

If you choose not to measure rainfall, no more references to rainfall will appear in the rest of the program.

pH UNITS OF MEASURE

• pH • • NOT MEASURED •

pH measurement determines the relative acidity or alkalinity of a solution. You must have an Isco pH Probe (or approved equivalent) connected to the flow meter through the parameter port to sense pH. pH measurements range from 0 to 14 pH units, with solutions below 7 considered acidic and solutions above 7, alkaline. (Pure water's pH is 7.)

These devices require periodic calibration for accurate sensing of pH. See Section 4 (Accessories) for more information about the pH probe. If you are not using a pH probe you would select NOT MEASURED for this step.

- If you choose NOT MEASURED for pH, no more references to pH will appear for the rest of the program.
- If you select pH, you will be unable to measure D.O. and no more references to D.O. will appear in the program.
- If your situation requires the measurement of both parameters (pH and D.O.) at the same time, or if you also need to measure conductivity, use the YSI 600 Multi-Parameter Sonde.

If you select NOT MEASURED and press Enter, the following will appear:

D.O. UNITS • MG/L • • PPM • • NOT MEASURED •

Measurement of dissolved oxygen is conducted in studies of water quality in lakes and streams. Some dissolved oxygen is necessary for the survival of aquatic life in these waters.

You must have a Teledyne Isco Dissolved Oxygen Probe to sense dissolved oxygen. The probe attaches to the 270 Module, which attaches to the Parameter Port. Probes require periodic calibration for accurate sensing.

☑ Note

The 270 D.O. module has been discontinued. Probes, service kits, and accessories are still available to maintain existing field units.

See Section 4 in the manual (Accessories) for more information about the dissolved oxygen probe. PPM = parts per million; MG/L = milligrams per liter. If you are not using the D.O. probe, you would select NOT MEASURED for this step.

Selection of NOT MEASURED will keep D.O. from appearing on subsequent programming menus.

Selection of PPM or MG/L will keep references to pH from showing up on subsequent menus.

TEMPERATURE UNITS

• DEG F • • DEG C • • (NOT MEASURED) •

This step sets up temperature measurement of the flow stream. You must have an Isco Temperature Probe attached to the flow meter's Parameter Port. The temperature probe contains a thermistor and needs no further calibration.

Measurement is in degrees Celsius or degrees Fahrenheit. If you are not using the

temperature probe, you would select NOT MEASURED for this step.

Selection of NOT MEASURED will keep TEMPERATURE from appearing in subsequent programming menus.

Note that if you are using either the pH or D.O. probe, temperature must be measured; the NOT MEASURED option will not even appear.

The following menus concern the YSI 600 Multi-Parameter Sonde. This probe lets you measure several different characteristics of a flow stream at the same time. The YSI 600 Sonde attaches to the Rain Gauge connector on the Model 4210. Note that this connector must be a special, modified connector with nine pins.

 **Note**

Model 4210 Flow Meters with 4-pin Rain Gauge connectors cannot support the YSI 600. You must return the flow meter to the factory for modifications if you wish to use a YSI 600 Sonde. In addition to the connector, there are significant internal modifications to the flow meter.

You can use both the YSI Sonde and a Rain Gauge on flow meters that support the YSI with a special Y-connect cable. Note that the YSI 600 Sonde differs from the previously-mentioned pH and D.O. probes. The YSI 600 can measure pH and D.O. at the same time, as well as temperature and conductivity. If you are not using the YSI 600 sonde, select NO in the following display and the flow meter

will advance to the next step. Otherwise, select YES.

YSI 600 CONNECTED
• YES • • NO •

If you select NO, you will be unable to activate the YSI Sonde later in the program.

If no communication has been confirmed, the following will appear:

YSI COMMUNICATIONS CHECK
• YES • • NO •

NO is the default. If you select YES, the following will appear:

WARNING - DO NOT DISCONNECT POWER
YSI COMMUNICATION CHECK. PLEASE WAIT...



CAUTION

Do not disconnect either the sonde or flow meter power during a communications check. The memory in the sonde can be damaged by a power failure during an update.

If the communications check is bad, the following will appear:

COMMUNICATIONS CHECK FAILED
PRESS ENTER TO CONTINUE

Note

The flow meter cannot communicate at 600 baud. If your sonde has been set up for 600 baud, you will get a communications failure. Consult the YSI 600 Manual for what to do in this case.

If the communications check is good, the following will appear:

```
COMMUNICATIONS RATE SET AT 2400 BAUD
PRESS ENTER TO CONTINUE
```

Press **ENTER**, and the flow meter will advance to the following:

```
YSI 600 pH UNITS OF MEASURE
• pH • • NOT MEASURED •
```

Selection of **NOT MEASURED** from any of the YSI menus will prevent you from activating that function later in the program.

If you wish to make use of the YSI 600 sonde's pH measurement capability, select **pH**. If you do not, select **NOT MEASURED**.

```
YSI 600 D.O. UNITS OF MEASURE
• MG/L • • NOT MEASURED •
```

If you wish to make use of the YSI 600 sonde's D.O. measurement capability, select **MG/L**. Otherwise, select **NOT MEASURED**.

```
YSI 600 CONDUCTIVITY PARAMETER
YSI SP COND• • YSI SALINITY• • YSI CONDUCTIVITY•>
```

For any of the **YSI CONDUCTIVITY** options, if you press **Enter**, the following display will appear:

```
TEMPERATURE COEFFICIENT
1.91%
```

This value is provided because conductivity rises (~2% / °C) with temperature. The default setting is 1.91%. This value is the temperature

coefficient for pure KCl (potassium chloride) in water. For other salts this value will be somewhat inaccurate, but it does provide a close approximation for solutions of many common salts, such as NaCl (sodium chloride), NH₄Cl (ammonium chloride) and sea water. If you use the value of 1.91, in most cases you will be able to identify that gross changes are occurring in the ionic content of the stream.

Moving with the right arrow, the following options will appear on the display:

```
YSI 600 CONDUCTIVITY PARAMETER
• YSI T.D.S. • • NOT MEASURED •
```

T.D.S. stands for “total dissolved solids.” T.D.S. are measured in parts per thousand (ppt).

```
TDS SCALE FACTOR
0.75
```

Total dissolved solids are estimated by multiplying conductivity by an empirical factor. This factor can vary between 0.55 and 0.9 depending on the solubility of the ionic components in the water and its temperature.

```
YSI 600 TEMPERATURE UNITS
• °F • • °C • • NOT MEASURED •
```

Select the appropriate units for your application.

3.2 Step 2 - Flow Conversion (Level-to-Flow)

If you select step 2, the following display will appear:

FLOW CONVERSION TYPE WEIR/FLUME • • EQUATION • • MANNING • • DATA POINTS •

WEIR/FLUME = weir or flume

EQUATION = equation

MANNING = Manning

DATA POINTS = data points.

If you select WEIR/FLUME, the following display will appear:

TYPE OF DEVICE: • WEIR • • FLUME •

Detailed information on weirs and flumes is published in the Teledyne Isco *Open Channel Flow Measurement Handbook*, which can be ordered from Teledyne Isco. Consulting the manufacturer of the specific weir or flume is also worthwhile. Note that for weirs and flumes, there is a preferred location for installing the level measuring device. Proper mounting of the level measurement device and accurate measurement of the level at the calibration point are essential for accurate flow calculation by the flow meter.

If you select WEIR, the following will appear:

SELECT TYPE OF WEIR: • V-NOTCH • • RECTANGULAR • • CIPOLLETTI •
--

If you select V-NOTCH, the following will appear:

SELECT V-NOTCH WEIR ANGLE (IN DEGREES)
• 22.5 • • 30 • • 45 • • 60 • • 90 • • 120 •

If you select RECTANGULAR for the weir, the following will appear:

END CONTRACTIONS ON RECTANGULAR WEIR:
• YES • • NO •

If you select YES, the following will appear:

RECTANGULAR WEIR WITH END CONTRACTIONS
ENTER CREST LENGTH XX.XXX FEET (or meters)

If you select CIPOLLETTI for the weir, the following will appear:

CIPOLLETTI WEIR
ENTER CREST LENGTH XX.XXX FEET (or meters)

If you selected FLUME for the device, the following will appear:

SELECT TYPE OF FLUME
• PARSHALL • • PALMER-BOWLUS • • LEOPOLD-LAGCO •

Also available with the arrow key:

SELECT TYPE OF FLUME
• HS • • H • • HL • • TRAPEZOIDAL

If you select PARSHALL for the flume, the following will appear:

SELECT PARSHALL SIZE:
1" • • 2" • • 3" • • 6" • • 9" • • 1.0' • • 1.5' • • 2.0' •

If you press the right arrow key several times, the sizes shown below will move onto the screen:

SELECT PARSHALL SIZE:
• 3' • • 4' • • 5' • • 6' • • 8' • • 10' • • 12' •

If you select PALMER-BOWLUS for flume, the following will appear:

SELECT PALMER-BOWLUS SIZE
4" • • 6" • • 8" • • 9" • • 10" • • 12" • • 15" • • 18" • • 21"

If you press the right arrow key several times, the sizes shown below will move onto the screen:

SELECT PALMER-BOWLUS SIZE
• 24" • • 27" • • 30" • • 48" •

If you select LEOPOLD-LAGCO for flume, the following will appear:

LEOPOLD-LAGCO FLUME SIZE
4" • • 6" • • 8" • • 10" • • 12" • • 15" • • 18" • • 21"

If you press the right arrow key several times, the sizes shown below will move onto the screen:

LEOPOLD-LAGCO FLUME SIZE
• 24" • • 30" •

If you select HS for the type of flume, the following will appear:

HS FLUME SIZE
• 0.4' • • 0.5' • • 0.6' • • 0.8' • • 1.0' •

If you select H for the type of flume, the following will appear:

```
H FLUME SIZE
5' . . .75' . . . 1' . . . 2' . . . 2.5' . . . 3' . . . 4.5' .
```

If you select HL for the type of flume, the following will appear:

```
HL FLUME SIZE
. 2.0' . . . 2.5' . . . 3.0' . . . 3.5' . . . 4.0' .
```

If you select TRAPEZOIDAL for the flume, the following will appear:

```
TRAPEZOIDAL SIZE
. LG 60 V . . . 2" 45 WSC . . . 12"45 SRCRC .
```

(This completes the section on WEIR/FLUME flow conversions.)

Returning to step 2, SELECT FLOW CONVERSION:

If you select EQUATION the following display will appear:

```
ENTER EQUATION UNITS
Q = XXX.XXXH^X.XX + XXX.XXXH^X.XX
```

This step allows you to enter an equation that is appropriate for your flow situation. The equation is expressed in the general form of $Q = k_1H^{P_1} + k_2H^{P_2}$, where Q = flow rate, k_1 = a constant, H = level or head, and P_1 is the power to which k_1 and H are raised. k_2 and P_2 are a second constant and power found in some equations. If your equation has only one term, you should enter 0 for the second constant.

Again returning to step 2, SELECT FLOW CONVERSION, if you select MANNING, the following display will appear:

```
SELECT MANNING TYPE
• ROUND PIPE • • U-CHANNEL • • RECTANGULAR • • T-
```

TRAPEZOIDAL is also available, if you move to the right with the right arrow key.

If you select ROUND PIPE for the Manning flow conversion, the following displays will appear:

```
MANNING ROUND PIPE
SLOPE = X.XXXXXX ROUGH = X.XXXX
```

Slope is entered as a dimensionless quantity, delta Y/ delta X, not as percent slope. Or, as otherwise expressed:

$$\frac{\Delta X = \text{Rise}}{\Delta Y \text{ Run}} \quad \text{For example: } 1 = \frac{0.1}{100}$$

Roughness coefficients are published in the Teledyne Isco *Open Channel Flow Measurement Handbook*. You can obtain this book from Teledyne Isco if you do not have a copy. Call Teledyne Isco for details. You must know the material the pipe is made of. The roughness coefficients are published for all common materials in three grades: minimum, normal and maximum. Then:

```
MANNING ROUND PIPE
DIAMETER = X.XXX FEET (or meters)
```

If you select U-CHANNEL for the Manning flow conversion, the following displays will appear:

```
MANNING U-CHANNEL  
SLOPE = X.XXXXXX ROUGH = X.XXX
```

(Slope and roughness are entered as for ROUND PIPE.) Then:

```
MANNING U-CHANNEL  
WIDTH = X.XXX FEET (or meters)
```

If you select RECTANGULAR for the Manning flow conversion, the following displays will appear:

```
MANNING RECTANGULAR  
SLOPE = X.XXXXXX ROUGH = X.XXX
```

(Slope and roughness are entered as for ROUND PIPE.) Then:

```
MANNING RECTANGULAR  
WIDTH = X.XXX FEET (or meters)
```

If you select TRAPEZOID for the Manning flow conversion, the following displays will appear:

```
MANNING TRAPEZOID  
SLOPE = X.XXXXXX ROUGH = X.XXX
```

(Slope and roughness are entered as for ROUND PIPE.) Then:

```
MANNING TRAPEZOID  
TOP WIDTH = X.XXX FEET (or meters)
```

Then:

```
MANNING TRAPEZOID  
BOTTOM WIDTH = X.XXX FEET (or meters)
```

Returning to step 2, FLOW CONVERSION TYPE, if you select DATA POINTS, the following will appear:

SELECT DATA SET

• ONE • • TWO • • THREE • • FOUR • • (NONE) •

Then:

LEVEL UNITS FOR DATA POINT ENTRY

• FT • • IN • • M • • MM •

This allows you to enter data points that are in different units than you are using. Then:

FLOW RATE UNITS

GPM • • GPS • • MGD • • CFS • • CFM • • M3S • • M3H • • M3D •

If you press the right arrow key several times, the following units will appear on the display:

FLOW RATE UNITS

LPS • • CFD • • GPH • • AFD • • CFH • • CFM • • M3M •

GPM = gallons per minute

GPS = gallons per second

MGD = million gallons per day

CFS = cubic feet per second

CFM = cubic feet per minute

M3S = cubic meters per second

M3M = cubic meters per minute

M3H = cubic meters per hour

M3D = cubic meters per day

LPS = liters per second

CFD = cubic feet per day

GPH = gallons per hour

AFD = acre-feet per day

CFH = cubic feet per hour.

DATA POINT flow conversion allows you to enter measured level and flow rate values for a number of different points. The Model 4210 Flow Meter can accept up to four sets of data points with each set containing as many as fifty points. The flow meter then performs a three-point interpolation to calculate a flow rate appropriate for the data entered. The common use of data point flow conversion is with unusual primary measuring devices, specifically devices that the 4210 does not support in the WEIR/FLUME flow conversion set. The level-to-flow rate data for such devices is usually available from the manufacturer. From this data the flow meter can create a flow conversion based on the relationship between the level and flow rate.

After the FLOW RATE UNITS menu has appeared, the next menu is:

```
SET X (1-4): (0) POINTS ENTERED
• ADD POINT • • (UNITS) •
```

Then:

```
SET 1 DATA POINT 1
ENTER: 0.00 (level units) 0.000 (units of volume)
```

After you have entered the data point set the following will appear:

```
SET X (1-4): XX (1-50) POINTS ENTERED
USE)• •EDIT POINT• •ADD POINT• •CLEAR• •PRINT•
```

UNITS, SAVE will also appear if you move the flashing cursor with the right arrow key. USE will only appear after four points have been

entered. USE tells the flow meter that the set is complete and can be used for the flow rate calculation.

Select EDIT POINT if you need to change either the level or the flow value for a particular data point.

Select ADD POINT if you want to add another point to a data set.

CLEAR will erase a set of data points from the flow meter's memory.

PRINT will make the flow meter print out the entire data set.

UNITS allows you to set or change the units of measure used in the data set. Note that you can only set UNITS if the set is empty, or you have cleared it. You cannot change the units once you have entered data points into a set, unless you clear it and start over.

SAVE tells the flow meter to save the data set as it is.

If you select either EDIT POINT or ADD POINT, the following display will appear:

SET X (1-4) DATA POINT XX (1-50) ENTER: XX.XX (level units) XXX.XXX (volume)

3.2.1 Enter Maximum Head

Before advancing from step 2 (Flow Conversion) to step 3 (Adjust Ports), the flow meter will request that you enter a value for Maximum Head (Level) for the device or flow conversion you are using.

For most standard measuring devices this information is published or is available from the device manufacturer. Note, however that you should not arbitrarily use the largest value available. Instead, use the value that is the largest expected level for your actual situation, even if this is less than the published maximum.

The flow meter's internal resolution and its accuracy are based on the value you enter for Maximum Head. The flow meter will display:

FLOW RATE AT MAXIMUM HEAD X.XXX CFS (or other units of measure)
--

3.2.2 Programming the 4–20 mA Outputs

If you turn on any of the 4–20 mA outputs (ANALOG OUTPUTS) in step 1- Setup, programming the actual operation of the output appears in step 2 - Select Flow Conversion.

 Note

If you do not turn on the 4–20 mA output(s) in step 1, the menus determining its (their) operation will not even appear later in the program. If you need this function and cannot find the appropriate menus in step 2, return to step 1, Setup and check to see that you have not inadvertently switched the option off.

For each 4–20 mA output port turned on, the flow meter will request entry of the type of data that will drive the output, along with minimum and maximum values. Here is an example of

what you might see for programming analog output 1.

```
DATA TYPE FOR ANALOG OUTPUT 1
(OFF) • (LEVEL) • (FLOW RATE) • (VELOCITY) • (pH) •
```

TEMPERATURE, DISSOLVED OXYGEN, CONDUCTIVITY, SPECIFIC CONDUCTANCE, SALINITY, and TOTAL DISSOLVED SOLIDS may also appear as driving conditions.

The actual choices available to you will depend on what ports you have turned on previously and what accessories (YSI, pH, D.O. probes, rain gauge, etc.) you are using with your flow meter. After you select one of the choices available to you, the flow meter will request that you enter minimum and maximum values for that choice:

```
ANALOG OUTPUT PORT 1
4 MA = X.X (units)
```

Note that 4 MA in the second line of the display could also be 0 MA if that is what you selected for the current loop minimum in Setup. The units are the units of measure appropriate for the option you selected; for example, feet or meters for level, degrees F or C for temperature, mg/l for dissolved oxygen, etc. After you have set the minimum value for the port, the flow meter will request you to enter a value for full-scale, or 100%:

```
ANALOG OUTPUT PORT 1
20 MA = X.X (units)
```

This value causes the port to transmit 100% or 20 mA. For example if the data type selected for this output were level, and the unit is measuring level in a four-foot pipe, you would enter a full-scale value of four feet. If the actual level reading is currently two feet, the analog output would read 12 mA (50% if the 4–20mA current range is selected) or 10 mA (50% if the 0–20 mA current range is selected).

The flow meter will then request that you repeat the process of defining the data type and setting the minimum and maximum values for any of the other analog ports you activated previously in Setup.

The flow meter's internal resolution and its accuracy are based on the value you enter for Maximum Head. The flow meter will display:

MAXIMUM FLOW X.XXX CFS (or other units of measure, as selected.)

3.3 Step 3 - Port to Adjust

This step lets you enter the measured level in the flow stream. It also lets you calibrate the pH (acidity or alkalinity), D.O. (dissolved oxygen) parameter sensors, and the YSI 600 Multiple Parameter Sonde. Note that there is no calibration step for the temperature sensor because it doesn't need calibration. When you select step 3 the following will appear:

PORT TO ADJUST •NONE• •(LEVEL)• •(pH)• •(D.O.)• •(YSI 600)•
--

LEVEL will not show up if you are using the flow meter only for parameter sensing. Likewise, pH and/or D.O. and YSI 600 will not show up on the display if you have locked them out by programming.

Remember that selection of either pH or D.O. in step 1 will keep the other from appearing on the display in this or subsequent programming steps. If the parameter you want does not appear in this menu, exit the program and return to Setup. Check to see that you have not accidentally locked your choice out with selections you made in the early section of the program.

If you select NONE, the flow meter will advance to the next step. If you select LEVEL, the following will appear:

ENTER CURRENT LEVEL X.XXX FEET (or meters)

First measure the level in the flow stream. This is usually done with a measuring stick, or you read the level from a scale that may be painted or printed on the side of the primary measuring device.

 Note

It is very important to enter accurate measurements for both the level in the stream and the dimension(s) of the channel, as all calculations of flow will be based on these measurements. If the values entered are incorrect, even by relatively small amounts, all subsequent flow calculations will be incorrect also.

For example, an error of only $\frac{1}{4}$ " for a 3" level and $\frac{1}{4}$ "

for a 10" diameter round pipe can result in a combined error of over 14%!

Errors in level measurement have a greater effect on flow calculations at low liquid levels. Dimensional errors tend to be more significant at higher levels.

Enter this value with the number keys. Note that LEVEL ADJUST must be done at the job site, while most other programming can be done in the shop. Unless you have reliable information about the size of the channel, you should measure that, also.

If you select pH for port to adjust, the following display will appear. (Note that pH will not appear as an option unless you have selected it in step 1.) If you want to measure pH and pH does not appear in this step, you must go back to step 1 and select pH instead of NOT MEASURED.

pH CALIBRATION

• pH 4 & 7 • • pH 7 & 10 • • pH 4, 7, & 10 •

You can perform a two- or three-point calibration for pH with the pH sensor. Select the calibration that best suits your stream's profile. If the pH in your stream is generally below 7, you would probably select pH 4 & 7. If the pH is generally above 7, you would probably select pH 7 & 10. If your stream's pH varies a great deal, say from 3 to 12, your best choice would be pH 4, 7, & 10. Then:

RINSE PROBE AND PLACE IN 4.0 pH SOLUTION

PRESS ENTER WHEN STABLE X.XX pH

The flow meter will direct you to repeat this process with the other standard buffers (7 and/or 10) to calibrate the pH sensor. If the probe fails to provide the correct output with any of the buffer solutions you will receive the following message:

```
pH BUFFER/PROBE OUT OF RANGE
PRESS ENTER TO CONTINUE
```

If you select D.O. for port to adjust, the following will appear:

```
DISSOLVED OXYGEN CALIBRATION
• D.O. STANDARD • • ABS BAROMETRIC PRESSURE •>
```

ALTITUDE is just off screen to the right. If you select D.O. STANDARD for the calibration method, the following display will appear:

```
D.O. STANDARD
0.00 MG/L
```

If you select ABS (absolute) BAROMETRIC PRESSURE the following will appear:

```
ABS BAROMETRIC PRESSURE
X.XX mmHg
```

Note that absolute barometric pressure is barometric pressure not corrected to sea level. The barometric pressure published by the U.S. Weather Bureau is corrected to sea level. If you use their value, you must convert it to the absolute pressure for your altitude. You should use Weather Bureau barometric pressure only if you are at sea level, or are able to correct the Weather Bureau figure to absolute pressure at

your location. Enter the value for atmospheric pressure.

WRAP D.O. PROBE IN MOIST CLOTH
PRESS ENTER WHEN STABLE: X.XX MS/CM:

Then the display will advance to the following:

CALIBRATING...
PLEASE WAIT...

If you select **ALTITUDE** for D.O., the following will appear:

UNITS FOR ALTITUDE ENTRY
• FT • • M •

Select the appropriate units and press Enter.

ALTITUDE
ALTITUDE = X.XX FT (or meters)

Enter the altitude for your location. Then:

WRAP D.O. PROBE IN MOIST CLOTH
PRESS ENTER WHEN STABLE: X.XXX MG/L

For more detailed information on the pH and D.O. probes, see Section 4 (Accessories) in the Model 4210 Instruction Manual.

Returning to step 3, Parameter to adjust, the following display will appear:

PARAMETER TO ADJUST
• NONE • • (LEVEL) • • (pH) • • (DO) • • (YSI 600) •

 **Note**

If you are using the YSI Sonde and YSI 600 does not appear on your display, return to step 1, Program, and

make sure you have selected YES from the YSI CONNECTED menu.

If you select YSI 600, the following display will appear:

```
YSI 600 PARAMETER TO CALIBRATE
• NONE • • pH • • DO • • CONDUCTIVITY •
```

If you select pH for the parameter to calibrate, the following display will appear:

```
YSI 600 pH CALIBRATION
• pH 4 & 7 • • pH 7 & 10 • • pH 4, 7, & 10 •
```

You can perform a two- or three-point calibration for pH with the YSI sonde. The menus that follow are similar to those in the preceding section for the Isco pH sensor. Select the calibration that best suits your stream's profile. When you complete the pH calibration successfully, the following display will appear:

```
CALIBRATING...
PRESS ENTER TO CONTINUE
```

Returning to the YSI menu, if you select D.O:

```
YSI 600 DISSOLVED OXYGEN CALIBRATION
• D.O. STANDARD • • ABS BAROMETRIC PRESSURE •>
```

ALTITUDE is just off screen to the right. Programming for YSI 600 D.O. is essentially the same as that described for the Isco D.O. sensor on the preceding section, with the exception that you always place the sensor in a cup, rather than wrap a moist cloth around it as is done for the Isco D.O. sensor.

If you select CONDUCTIVITY for the parameter to calibrate, the following display will appear:

```
CONDUCTIVITY CALIBRATION UNITS
• MS/CM • • PPT •
```

MS/CM is milli-siemens per centimeter. The siemen is the S.I. (Système Internationale) name for the unit of conductance, which is also the reciprocal of the ohm. The siemen was formerly called the mho (ohm spelled backwards), and that term is more familiar to some. PPT is parts per thousand. Select the standard most suitable for your application.

```
CONDUCTIVITY STANDARD
X.XX MS/CM
```

Then:

```
PLACE PROBE IN X.XX MS/CM
PRESS ENTER WHEN STABLE: X.XX MS/CM
```

Then:

```
CALIBRATING...
PLEASE WAIT...
```

If you select PPT for the conductivity standard:

```
CONDUCTIVITY STANDARD
X.XX PPT
```

Then:

```
PLACE PROBE IN X.XX PPT
PRESS ENTER WHEN STABLE: X.XX MS/CM
```

Then:

```
CALIBRATING...  
PLEASE WAIT...
```

Note that there is no need to calibrate the YSI 600 temperature sensor, as it is self-calibrating.

3.4 Step 4 - Reset Totalizer

This step allows you to reset the flow meter's internal flow totalizer. Note that there is the possibility of more than one totalizer. The Model 4210 has the capability of maintaining a separate totalizer for the time the sampler is enabled through the sampler enabling feature (step 6).

If you select step 4, the following will appear. If you select NO, the flow meter will advance to the next step. If you select YES, the flow meter will reset the internal totalizer to zero.

```
RESET TOTALIZER  
• YES • • NO •
```

Then, if you have sampler enabling turned on (Step 6), the flow meter will ask you whether you want to reset the totalizer for the total flow during the time the sampler was enabled. (See step 6 for an explanation of sampler enabling.)

```
ENABLE TOTALIZER XX CF (or other units of measure)  
PRESS 'ENTER'
```

Then:

```
RESET SAMPLER ENABLE TOTALIZER  
• YES • • NO •
```

3.5 Step 5 - Sampler Pacing

This step determines how the flow meter signals an associated wastewater sampler to take a sample. The flow meter and sampler are connected with a cable. The flow meter sends flow pulses to the sampler. The sampler uses these flow pulses as counts. When an appropriate number of flow pulses has been received by the sampler, it will take a sample. If you select step 5, the following will appear:

```
SAMPLER PACING
DISABLE • •(VOLUME) • •(FLOWLINK) • •CONDITIONAL •
```

VOLUME will not appear if the flow meter is measuring level only, or is being used for parameter monitoring. The **FLOWLINK** menu option will not appear unless **FLOWLINK** software is installed and pacing has been downloaded from **FLOWLINK**.

If you select **DISABLE** for sampler pacing, the flow meter will be effectively disconnected from the sampler. The sampler will run its program as if the flow meter weren't there. Selection of **DISABLE** will also cause the flow meter to advance to the next Program step. If you select **VOLUME** for sampler pacing, the following will appear:

```
SAMPLER PACING
ENTER PACING VOLUME XX.XXXX CF
```

Other units of measure, as previously selected, may appear here.

The range for pacing is max. flow \div by 100 (minimum) or $10,000 \times$ max. flow (maximum.)

If FLOWLINK appears for sampler pacing, the operation of sampler pacing has been determined by choices made in Flowlink.

Flowlink controls the flow meter remotely, via phone lines and a modem, or locally with a laptop computer and cable. In any event, if the sampler pacing definition is controlled by Flowlink, it can only be changed through Flowlink.

If you select CONDITIONAL for pacing, the following will appear:

CONDITION (LEVEL) • •(FLOW RATE) • •(RAINFALL) • •(D.O.) • •(pH) •

TEMPERATURE, YSI pH, YSI D.O., YSI CONDUCTIVITY and YSI TEMP may also appear. Note that all the conditions shown above are in parentheses. Which ones actually appear depend on your previous programming selections. At least one of these menu options will be available to you. Pressing the right arrow key may be necessary to bring all items onto the display, (provided they are available for use.)

LEVEL appears only if the flow meter is set up to measure level or flow.

RAINFALL, D.O., pH, and TEMPERATURE measurement require the appropriate sensor probe be used with the flow meter. Remember that only one parameter condition (D.O. or pH) can be measured by the flow meter at a time.

RAINFALL can appear if you have a rain gauge attached.

TEMPERATURE can be measured alone, or with pH or D.O.

D.O. and/or pH may not appear on the menu, depending on selections made in step 1. If you do not see the item you need, return to step 1, and recheck your programming. If you did not make the proper selections there, certain menu options will not appear here, as they would have been locked out.

The YSI 600 conditions of pH, D.O., CONDUCTIVITY, and TEMPERATURE will only appear on the menu if you have turned them on in steps 1 and 3.

For any of these conditions, you can set the point at which change in the selected condition causes the flow meter to send a flow pulse to the sampler. The following menu will appear:

CONDITION

• GREATER THAN • • LESS THAN • • RATE OF CHANGE •

If you select GREATER THAN, the flow meter will ask you to enter a maximum value for the selected condition, which if exceeded, will trigger the flow pulse.

If you select LESS THAN, the flow meter will ask you to enter a minimum value for the selected condition. If the condition falls below that value later, the flow meter will send a flow pulse to the sampler.

If you select RATE OF CHANGE, the flow meter will ask you to enter two values, one for

the condition, and the other for a period of time over which the change occurs.

After you have determined what condition will signal the sampler and under what circumstances, the following menu will appear:

SELECT OPERATOR • DONE • • OR • • AND •
--

SELECT OPERATOR allows you to trigger the sampler from a single condition or from two conditions. Suppose you wanted to trigger the sampler from only one condition and that condition was LEVEL. You would select level as the condition, and then identify what change in LEVEL would be the trigger. Then you would select DONE for the SELECT OPERATOR step. Selection of DONE will advance the flow meter to the next program step.

However, suppose you wanted to select two conditions, either of which would trigger the sampler. In such a case you would select OR for the SELECT OPERATOR step. The menu will return to the one listing the conditions. This will let you define the second condition. Now the flow meter will trigger the sampler when either condition changes.

Finally, suppose you had a situation where you wanted changes in two conditions to occur before you signalled the sampler. In that case you would select AND for the SELECT OPERATOR step. Then you would define the second condition. Now the flow meter will

signal the sampler only after both conditions have changed.

The next screen on the flow meter (after you have established the conditions for sampler pacing) will request the following. (Entering 0 sends no pulses):

CONDITION TRUE PACING INTERVAL PACE EVERY X MINUTES
--

This option allows you to send flow pulses periodically to the sampler during the time the conditions you established for sampler pacing are being met. Then:

CONDITION FALSE PACING INTERVAL PACE EVERY X MINUTES

This option allow you to send flow pulses periodically to the sampler during the time the conditions you established for sampler pacing are not being met. Again, entering 0 sends no pulses.

3.6 Step 6 - Sampler Enable

The operation of step 6 Sampler Enable is similar to step 5, Sampler Pacing. The menus and options are similar. The difference is that where sampler pacing only causes the flow meter to send a momentary signal (flow pulse) to the sampler, sampler enabling actually controls an inhibit line to the sampler that can keep the sampler from running its program. Sampler enabling is useful where the sampler

needs to remain idle for long periods of time, such as storm water runoff applications.

When you select or advance to step 6, the following will appear:

SAMPLER ENABLE MODE

• DISABLE • • ENABLE • • CONDITIONAL • • (STORM) •

FLOWLINK may also appear. The FLOWLINK menu option will not appear unless Flowlink software is installed.

DISABLE means that the sampler will be permanently inhibited by the flow meter. This condition will remain until you change it in this program step, or if you are using Flowlink, until it is overridden by a command from FLOWLINK.

Select the DISABLE option with care; it will make the sampler appear to be inoperative, and that could easily be misinterpreted as an equipment failure by someone unfamiliar with the equipment.

ENABLE means that the sampler is permanently enabled, free to run its own program without any control from the flow meter. This condition will remain until you change this menu option, or until it is overridden by a command from FLOWLINK.

The STORM option will not appear unless you turned on rainfall measurement in step 1.

STORM selection is what you use when you want to monitor storm water runoff.

STORM enabling is really a combination of conditions. First, enter a value for LEVEL in

the flow stream. Second, enter a value for RAINFALL. Third, enter an amount of time over which the rainfall occurs. Finally, you enter a time since the last rainfall. You must have an Isco Rain Gauge, or approved equal to measure rainfall. The following menus are the STORM sequence.

Followed by:

LEVEL GREATER THAN X.XXX FT (or other units of measure)
--

Then:

RAINFALL AMOUNT X.XX INCHES (or other units of measure)
--

Then:

RAINFALL TIME PERIOD • 15 MIN • • 30 MIN • • 1 HR • • 2 HR • • 4 HR •
--

If you press the right arrow key several times, the following times will appear:

RAINFALL TIME PERIOD 6 HR • • 8 HR • • 12 HR • • 24 HR • • 48 HR • • 72 HR •

The intervals above are the periods of time over which the rainfall occurs. The amount of rain entered in the previous step and detected by the rain gauge must fall during the time interval chosen from this menu before the flow meter recognizes the event as a storm.

The next menu defines the interval that must pass between storm events.

TIME SINCE LAST RAINFALL DAYS: X (allowable entry of 1-7)
--

If you select **CONDITION** from **SAMPLER ENABLE**, the following will appear:

CONDITION • (LEVEL) • • (FLOW RATE) • • (D.O.) • • (pH) •
--

TEMPERATURE, **RAINFALL**, **YSI pH**, **YSI D.O.**, **YSI CONDUCTIVITY** and **YSI TEMP** may also appear.

The above conditions are all shown in parentheses, because they may or may not be available to you by the time you reach this menu. The menus that do appear will depend on the flow meter type and programming selections made earlier in the program. At least one of the conditions will be available to you.

If you select **LEVEL** from **CONDITION** the following will appear:

LEVEL • GREATER THAN • • LESS THAN • • RATE OF CHANGE •
--

After you select one of these options, the flow meter will request that you enter a value, for example if you selected **GREATER THAN**:

LEVEL GREATER THAN X.XX FEET (or other units of measure)

Enter a maximum value for the selected condition, which if exceeded, will enable the sampler.

If you select **LESS THAN**, the flow meter will ask you to enter a minimum value for the selected condition. If the condition falls below that value later, the flow meter will enable the sampler.

If you select RATE OF CHANGE, the flow meter will ask you to enter two values, one for the condition, and the other for a period of time over which the change occurs.

After you have determined what condition will signal the sampler and under what circumstances, the following menu will appear:

```
SELECT OPERATOR
• DONE • • OR • • AND •
```

This step allows you to trigger the sampler from a single condition or from two conditions. Suppose you wanted to trigger the sampler from only one condition and that condition was LEVEL. You would select LEVEL as the condition, and then identify what change in level would be the trigger. Then you would select DONE for the SELECT OPERATOR step. Selection of DONE will advance the flow meter to the next program step. Selection of OR or AND will allow you to select another condition, and then determine whether both conditions are necessary for enabling (AND) or whether either condition will enable the sampler (OR).

If you select FLOW RATE:

```
FLOW RATE
• GREATER THAN • • LESS THAN • • RATE OF CHANGE •
```

You would select one of these options, and then enter a value, as for LEVEL, previously.

The rest of the menus will appear the same as they did for LEVEL and FLOW RATE. D.O.,

pH, TEMPERATURE, and RAINFALL all require activation in step 1 and use of the appropriate sensor. Only one parameter condition (pH, D.O.) can be measured by the flow meter at a time. pH and D.O. cannot appear on the display at the same time.

It is possible to program the sampler enable option so that it operates in two different modes, locking and nonlocking. To explain this, in the nonlocking mode the sampler will be enabled only as long as the condition that caused the enabling remains outside of "normal." If the enabling condition returns to "normal," the sampler enable will turn off until the next time the condition goes outside of "normal."

In the locking mode, the sampler will be enabled the first time the condition goes outside of normal and the sampler will remain enabled regardless of any subsequent changes to the enabling condition. If this is the case, the following menu will allow you to reset the sampler enable feature.

Note that this menu will not appear unless the condition necessary to enable the sampler has been met and the sampler is currently enabled.

WHEN ENABLE CONDITION IS NO LONGER MET • DISABLE SAMPLER • • KEEP ENABLED •
--

Or:

ENABLE CURRENTLY LATCHED, RESET • NO • • YES •

Select YES to reset the sampler enable feature; select NO to leave the sampler enabled.

PRINTER ON/OFF WITH ENABLE

• YES • • NO •

This selection allows you to turn the flow meter's internal printer on or off when the sampler is enabled from the flow meter. This allows you to conserve battery power and only print a chart when the sampler is enabled. This feature is useful for monitoring storm water runoff.

3.7 Step 7 - Alarm Dialout Mode

This step lets you signal an alarm to a remote location from the flow meter. The conditions that can cause an alarm are the same as described previously for sampler enabling.

Note

You must have the optional internal modem installed and connected to a telephone network to make use of this feature. This menu will not even appear if you do not have a modem. The flow meter will automatically advance to the next step.

More information about the modem can be found in Section 4 (Accessories) in the Model 4210 Instruction manual. If you have the modem installed and select step 7, the following will appear:

ALARM DIAL OUT

• DISABLE • • CONDITIONAL • • STORM • • FLOWLINK •

If you select **DISABLE**, this option will be inactivated until you change the selection later. The program will advance to the next step. If you select **STORM**, the flow meter will request definitions similar to those for **STORM** in sampler enable. The following will appear:

LEVEL GREATER THAN X.XXX FT (or other units of measure)
--

Followed by:

RAINFALL AMOUNT X.XX INCHES (or other units of measure)
--

Then:

RAINFALL TIME PERIOD • 15 MIN • • 30 MIN • • 1 HR • • 2 HR • • 4 HR •
--

If you press the right arrow key several times, the following times will appear:

RAINFALL TIME PERIOD 6 HR • • 8 HR • • 12 HR • • 24 HR • • 48 HR • • 72 HR •

The intervals above are the periods of time over which the rainfall occurs. The amount of rain entered in the previous step and detected by the rain gauge must fall during the time interval chosen from this menu before the flow meter recognizes the event as a storm.

The next menu defines the interval between storm events.

TIME SINCE LAST RAINFALL DAYS: X (allowable entry of 1-7)
--

If you select **CONDITIONAL**, the following will appear:

CONDITION

• (LEVEL) • • (FLOW RATE) • • (D.O.) • • (pH) •

TEMPERATURE, **RAINFALL**, **YSI pH**, **YSI D.O.**, **YSI CONDUCTIVITY**, and **YSI TEMP** may also appear. As mentioned previously, some of these menu options may not appear depending on selections you made earlier in the program. At least one of the options will be available to you. As mentioned previously, some of these menu options may not appear depending on the choices you made earlier in the program. **D.O.**, **pH**, **TEMPERATURE**, the **YSI** outputs, and **RAINFALL** all require activation in step 1 and connection of the appropriate sensor to the flow meter. **D.O.** and **pH** cannot appear together, as only one can be used at a time.

When you have selected the condition you want, the display will advance to the following:

CONDITION

• GREATER THAN • • LESS THAN • • RATE OF CHANGE •

For these conditions, you enter an amount which if exceeded (**GREATER THAN**), or if dropped below (**LESS THAN**), or if changed too quickly (**RATE OF CHANGE**), will activate the alarm dialout. For **RATE OF CHANGE**, you enter two values: amount and time over which change occurs. Then the display will advance to the following:

SELECT OPERATOR

• DONE • • OR • • AND •

As described for sampler enabling previously, this step allows you to combine conditions to produce an alarm dialout signal. Select DONE if you don't need more than one condition to trigger the alarm.

If you want either of two conditions to trigger an alarm, select OR.

If you want both of two conditions to be met before signalling an alarm, select AND. Selection of DONE will advance you to the next display menu. Selection of OR or AND will return you to the CONDITION menu to select the other condition.

The flow meter will then request that you enter the telephone numbers for the remote alarms. There are five possible telephone numbers, in decreasing order of importance. You can enter as many as eighteen digits for each phone, so the remote targets need not necessarily be local. You can also use the decimal key (.) to insert a comma into the number, which enters a two-second delay. Entering multiple commas will increase the delay.

ALARM DIALOUT NUMBERS

DONE • NUM 1 • NUM 2 • NUM 3 • NUM 4 • NUM 5

If you select DONE, the flow meter will advance to the next step. If you select one of the NUM entries, such as NUM 1, the following will appear:

FIRST PHONE NUMBER

XXXXXXXXXX

You can enter the phone numbers as straight seven or ten-digit numbers, or you can use the +/- key to enter a dash as telephone numbers are often written. If you want to signal more than one remote number at a time, the numbers are arranged in decreasing priority. NUM 1 carries the highest priority, followed by NUM 2 and so on.

After you have entered the numbers, the flow meter will request:

DELAY BETWEEN DIALOUTS XX MINUTES

This is the time delay between calling the first number and calling the second, etc. This option gives you time to respond to an alarm before the flow meter dials the next number. Select a value between 1 and 99 minutes. Then the display will advance to the following:

CALLBACK TO DISABLE ALARM • YES • • NO •

Select YES if you want to be able to acknowledge the alarm condition in the flow meter by calling back. No message is spoken on this callback. When the flow meter's modem detects the ring, it will answer and automatically reset the alarm. If there is no one available to answer an alarm, you can have the flow meter dial a paging service and then someone with a pager can call back to acknowledge the alarm. To acknowledge an alarm from a touch tone phone; wait for the spoken message to complete; then press

*-X-X-X. The X-X-X are the three digits of the site ID number.

3.8 Step 8 - Printer Setup

This step sets up the operation of the flow meter's internal printer. This printer also functions as a plotter. Note that the printer/plotter is capable of printing alphanumeric information (words and numbers), and at the same time, plotting linear data like flow, level, pH, etc. The unit can print as many as three different data lines at the same time it regularly records other printed information supplied from the flow meter. Program selections made in this step will determine the appearance of the printer/printer's chart. The first menu will request the speed of the chart.

ENTER PRINTER SPEED

• OFF • • 1/2"/HR • • 1"/HR • • 2"/HR • • 4"/HR •

If you select OFF, the printer will be disabled. No data will be printed on the chart. The flow meter will, however, still print reports if you activate that function in step 9. The choice made from the other speeds depends on the amount of data you need to record on the chart. If you are recording from a stable situation and are using only one data line, and you want to achieve maximum life for the roll of chart paper, you would select a lower speed for chart advance.

On the other hand, if there is a great deal of activity in your flow stream, and you need to use all three data lines, selection of a faster chart speed will probably produce a chart that is more easily read and interpreted. After you select the printer speed, the flow meter will ask you to define what input you want depicted by printer LINE A. (The printer can print up to three separate data lines at the same time.)

The following display will appear:

```
INPUT FOR PRINTER LINE A
(LEVEL)• •(FLOW RATE)• •(pH)• •(D.O.)• •OFF•
```

TEMPERATURE, YSI pH, YSI D.O., YSI CONDUCTIVITY, and YSI TEMP can also appear. Remember that menus in parentheses may or may not appear due to previous program selections. Either pH or D.O. may appear, but not both. The various YSI options will only appear if you have enabled the YSI 600 option in step 1, previously. You must have the appropriate probes to sense these conditions for the flow meter. Select OFF, if you do not wish to use this line. If you select pH, D.O., TEMPERATURE, or any of the YSI options, the flow meter will request that you set limits that will serve as the chart zero and the chart full-scale.

```
PRINTER LINE A BOTTOM SCALE
X.XXpH (or other condition, as selected previously)
```

Enter the lowest pH value you expect to see in your flow stream.

```
PRINTER LINE A FULL SCALE
```

X.XXpH (or other condition, as selected previously)

Enter here the highest pH value you expect to see in your flow stream. Note that selection depends on the range that you would normally see. If your stream varies from 6 to 8 pH units, you would not want to enter 0 and 14 as limits. The chart resolution would be poor. You could enter 5 and 9 pH and still have good resolution if there were sharp deviations because of the availability of over-ranges. Selection of OFF from the INPUT FOR PRINTER LINE menu will cause the printer to leave this line blank. Selection of conditions other than pH, D.O., TEMPERATURE, or YSI-functions will result in a request that you enter the full-scale value for the condition being plotted. For example, if you selected LEVEL as a condition, the following would appear:

PRINTER LINE A FULL SCALE
X.XXXXFEET (or other units of measure, as selected)

The flow meter will automatically go into over-range if the data goes higher than the full-scale value you have selected. You can easily recognize over-range operation by the plotted line running off the right side of the chart and then immediately reappearing on the left side of the chart. Because of the over-range feature, you can set a full-scale value that gives you good resolution on the chart.

At the same time, the automatic over-range will prevent the loss of recorded data if the plotted line rises past the full-scale point. For the other

conditions, the full-scale units will be appropriate for what is being measured (D.O., pH, temperature, etc.) the flow meter is capable of multiple over-ranges.

INPUT FOR PRINTER LINE B (LEVEL)• •(FLOW RATE)• •(pH)• •(D.O.)• •OFF•
--

TEMPERATURE, YSI pH, YSI D.O., YSI CONDUCTIVITY, and YSI TEMP may also appear. Again, just as for line A, you can select another condition to plot on the chart. The flow meter will request a full-scale value. The full-scale value can be different than that entered for line A.

INPUT FOR PRINTER LINE C (LEVEL)• •(FLOW RATE)• •(D.O.)• •(pH)• •OFF•
--

TEMPERATURE, D.O., YSI pH, YSI D.O., YSI CONDUCTIVITY, and YSI TEMP may also appear. For line C, you can select yet another condition to plot on the chart. The flow meter will also request entry of a full-scale, or bottom and full-scale values, as for the previous two lines.

PLOT RAINFALL ON CHART? • NO • • YES •

You must have an Isco Rain Gauge or equivalent connected to the flow meter to measure rainfall. Output is recorded in inches or millimeters. There is only one over-range for rainfall.

3.9 Step 9 - Reports/History

This step lets you set up the flow meter to print periodic reports. The typical report contains such information as the period of time covered in the report, maximum and minimum levels, and when they occurred. You can define two different reports in this step. For example, this is used to provide weekly and monthly reports. You can choose the content of the reports by working through the menus in step 1. When you go to step 9 the following will appear:

```
REPORT GENERATOR A
• ON • • OFF • • (PRINT) •
```

If you select OFF, the program will advance to the next step, and there will be no report A. If you select YES, the following will appear:

```
REPORT A DURATION TO BE IN
• HOURS • • DAYS • • MONTHS •
```

After you select the units of time, the following will appear.

```
ENTER REPORT A DURATION
XX HOURS
```

DAYS or MONTHS could also appear depending on what you selected for the previous step. The time selected becomes the time interval that will be covered in the report. Then the flow meter will ask you when you want the first report printed:

```
PRINT REPORT A AT
YR: XXXX MONTH: XX DAY: XX HR: XX MIN: XX
```

Then:

```
REPORT GENERATOR B
• ON • • OFF • • (PRINT) •
```

The second report generator lets you program the flow meter to print two independent reports at different intervals, for example. This is useful for those who need both a weekly and a monthly summary of activity on the flow meter. If you select OFF for this step, the program will advance to the next step, and there will be no report B generated.

If you select YES, the following will appear:

```
REPORT B DURATION TO BE IN
• HOURS • • DAYS • • MONTHS •
```

Select the appropriate interval for this second report. After you select the units of time the following will appear:

```
ENTER REPORT B DURATION
XX HOURS
```

DAYS or MONTHS could also appear depending on what you selected for the previous step. The time selected becomes the time interval that will be covered in the report. Then the flow meter will ask you when you want the first report printed:

```
PRINT REPORT A AT
YR: XXXX MONTH: XX DAY: XX HR: XX MIN: XX
```

After you have entered the desired date for the first report, the program will advance to the following:

```
PRINT FLOW METER HISTORY
• YES • • NO •
```

The final step on the flow meter is HISTORY. This step presents a record of the programming activity on the flow meter that you can have printed on the printer. The flow meter keeps a record of certain programming changes and prints them out. If you select YES, the following will appear:

```
PRINT FLOW METER HISTORY
• PRINT SINCE LAST • • PRINT ALL •
```

If you press PRINT SINCE LAST, the flow meter will only print the changes that have occurred since the last print request. If there were no changes, there will be no print. If you select PRINT ALL, the flow meter will print all the changes it has in memory, as far back as fifty entries.

If you selected NO from PRINT FLOW METER HISTORY, the flow meter will advance to CLEAR HISTORY - YES, NO.

If you select NO again, the flow meter will exit programming and return to the normal display. If you clear the memory, previous programming changes will be erased, but the flow meter will again begin keeping track of changes the next time you change the program.

Flow Meter History Contents -

D.O. ADJUSTED	REPORT B TURNED ON
pH ADJUSTED	REPORT A TURNED OFF
LEVEL ADJUSTED	REPORT B TURNED OFF
FLOW CONVERSION CHANGED	TOTALIZER RESET
PLOTTER SPEED CHANGED	INTERROGATED
PLOTTER TURNED ON	SAMPLER ENABLED
PLOTTER TURNED OFF	SAMPLER DISABLED
TIME CHANGE FROM	ALARM ACKED BY #X
TIME CHANGE TO	ALARM NOT ACKNOWLEDGED
REPORT A CHANGED	YSI pH ADJUSTED
REPORT B CHANGED	YSI D.O. ADJUSTED
REPORT A TURNED ON	YSI CONDUCTIVITY ADJ.

4210 Ultrasonic Flow Meter

Section 4 *Maintenance*

Depending on where you install the flow meter, relatively little needs to be done to keep the Model 4210 in good operating condition. Following the simple procedures outlined in the following sections will ensure a long, trouble-free life for the flow meter.

4.1 Care of the Flow Meter Case

If the lid is tightly latched, and all the connectors on the side of the case are tightly capped, you can clean the case by spraying it with a hose or washing it with soapy water. Do not use a hose with a nozzle or a high pressure hose-and-wand as used at car washes. Do not immerse the flow meter in a tank of water to wash it. While designed to withstand accidental submersion in water, if that happens, the flow meter is not intended for routine submersion.

 **CAUTION**

Use only soap and water to clean the flow meter. Do not attempt to use petroleum-based cleaning solvents (such as gasoline) or halogenated (containing chlorine) cleaning solvents. They could attack the plastic used in the case or cause the permanent fogging of the window.

4.1.1 Care of the Case Seal

Periodically inspect the case seal and clean it if necessary. The ridge extending around the edge of the flow meter cabinet forms a seal with the groove in the cabinet door. It should be free of dirt, sand, *etc.* If it isn't, clean it carefully with a damp cloth. The rubber gasket in the lid should also be clean; if not, you may clean it with a small brush and a damp cloth. If you do any cleaning while the case is open, be careful not to allow any dirt or debris to fall inside the flow meter case. It is best to work on the flow meter with the case standing upright. If you don't maintain the seals properly, they may leak, causing damage and eventual failure of the components inside.

4.1.2 Preventing Moisture Damage

To prevent moisture damage to internal components, keep the lid tightly latched at all times, except when you are changing the program or changing the paper roll for the printer. Do not operate the flow meter routinely with the case open; this will expose the internal

components to dirt and moisture. It will also cause the desiccant canister to fail quickly.

Keep the external connectors clean by keeping the mating connectors or the protective caps on unused connectors tightly screwed on. Under severe operating conditions you may spray the threads only of the connectors with a cleaner/lubricant (such as Jif or WD-40) to prevent corrosion. Be careful not to spray any of the conductive terminals (pins or jacks) inside the connectors; residue from the sprays can cause intermittent or failed contacts.

4.2 Changing the Printer Paper and Ribbon

The internal printer needs little maintenance beyond changing the chart roll and the ink ribbon. Refer to the label inside the cabinet.

To change the chart paper you will need:

- a new roll of paper
- a knife or a pair of scissors
- a small piece of tape

The printer will shut down when the paper runs out. The roll is nearly empty when a pink band appears on the left side of the chart.

To remove the empty roll: (Refer to the illustration inside the case.)

1. Locate the handle on the left side of the take-up roll.
2. Pull straight out on this handle until the take-up roll slips off the printer.

3. Remove the paper roll from the take-up spool by holding the handle in one hand with your thumb pressed against one of the slots in the white end cap.
4. Snap the white end cap free from the two black catches on the end of the spool.
5. Pull the paper roll off the spool with your other hand.
6. Remove the feed spool by pulling on the handle extending from the right side of the printer.
7. Snap off the other white end cap as described previously. Save the white end caps; you will reuse them.
8. Remove the empty roll from the spool by holding the handle in one hand and pulling the roll from the spool with the other.

Installing the New Roll of Paper

9. After you remove the empty roll, slide the new roll onto the feed spool so it unrolls from the back side - facing away from you.
10. Line up the slots in the cardboard tube with the raised guides on the spool.
11. Reattach the white end cap by wedging the two catches on the end of the spool into the two slots on the white end cap.
12. Peel the paper back gently so it will unroll freely. Using the knife or scissors, cut off the end of the roll if it is torn.

13. Fold the paper over on itself so the end is straight and stiffer than a single layer of paper would be.
14. Unroll a few inches of the paper and set the roll on top of the cabinet.
15. Use your fingers to feed the paper down the back of the internal printer to where it touches the roller. Make sure the paper gets past the lever for the paper sensing switch.
16. Then press the Chart Advance key and hold it until the paper comes through the printer mechanism.

Rethreading the Paper

17. When the paper comes through, reinstall the feed spool with the new roll on it by snapping it into the printer assembly.
18. Run a few inches through the printer, using the Chart Advance key; then unfold the end.
19. Put the cardboard tube from the empty roll on the take-up spindle and reattach the end cap by wedging the catches on the end of the spool into the two slots on the end cap.
20. Use the piece of tape to attach the end of the new paper to the cardboard tube from the old roll.
21. Roll some of the paper onto the spool so that it will wind clockwise, facing away from you. Then reinstall the take-up roll into the top of the printer.

Be careful to push it all the way back in, so that the take-up gear on the end of the spool assembly will reengage.

22. When the take-up spool is back in place, again push the Paper Reroll key; this will remove any slackness in the paper.

4.2.1 Ink Ribbon Replacement

Ribbon life depends on how often the printer has to print. When the characters on the chart become faint, replace the ribbon. If possible, try to replace the ribbon at the same time you change the paper roll, as it is easier to replace the ribbon when the roll of paper is out of the way. To replace the ribbon, first turn the unit off.

If there is paper in the unit, remove the take-up spool and unroll enough paper to get it out of the way, so you can clearly see the two ribbon spools. Each spool has a ribbon-detecting lever pressing against the ribbon. Note the direction the ribbon leaves the left spool and how it winds onto the right spool.

1. Take hold of one of the spools and rotate it slightly, loosening the ribbon.
2. Lift gently until the spool comes free from its shaft. Do the same with the other spool.
3. Lift the chart and take-up spool out of the way and remove the ink ribbon from the printer mechanism, noting how it threads through the unit.

4. Thread the new ink ribbon through the printer.
5. Locate the three pins on each spool of the ribbon and turn them so the pins face the gears on the two ribbon shafts.
6. Replace the two spools on their respective shafts, pushing the detector levers out of the way so the spools will easily re-engage their gears.
7. Gently rotate each spool to tighten the ink ribbon. Re-install the paper take-up roll if necessary.

4.3 Care of the Ultrasonic Level Sensor

The ultrasonic level sensor and cable require little maintenance. Periodically check to make sure the unit remains securely mounted. Any movement of the level sensor can have serious effects on the flow meter's accuracy and its response. The ultrasonic transducer is encapsulated inside the case to protect it from damage. The transducer is a special crystal with the face coated with rubber for protection. Do not drop the assembly nor try to take it apart. Dropping the unit or otherwise abusing it could cause the case to crack, or the wires inside the cable to break loose.

The level sensor contains no user-serviceable parts. Do not flex the cable where it comes out of the level sensor case. If the cable is flexed too much, some of the wires inside the cable may

break, ruining the level sensor. Mount the level sensor securely to avoid stressing the cable too much. If the level sensor surface is contaminated due to long-term use or submersion, performance may suffer. If this happens, you may need to clean the level sensor. You can clean the case with a brush, but don't damage the level sensor face with the brush. Clean the surface of the unit with soap and water.

4.4 Cable Inspection

Periodically inspect the cables connecting the ultrasonic level sensor to the flow meter. Look for deterioration caused by abuse or weathering. Damaged cables can affect operation of the ultrasonic level sensor and should be replaced. Keep connectors clean and dry. In permanent installations, install the cables so they are not at risk of being damaged by other activity going on in the area. Cables repeatedly subjected to abuse will fail and you should install them in conduit for protection. In temporary installations, avoid laying cables where they heavy equipment may run over them.

4.5 Maintenance of the Batteries

If your flow meter installation is battery-powered, you will have to recharge the battery periodically, unless you are using a solar panel battery charger with a lead-acid

battery. You may use an Isco Nickel-Cadmium Battery, Lead-Acid Battery, or an external lead-acid battery, such as a deep-cycle R-V or marine battery. The charging requirements and operating characteristics of lead-acid and nickel-cadmium batteries are different from each other and it is important to cycle and charge these batteries correctly. This will maintain reliable service from the flow meter and achieve maximum life from the batteries. The following sections cover nickel-cadmium batteries first, then lead-acid batteries.

4.5.1 Charging the Nickel-Cadmium Battery

Charge the nickel-cadmium battery either with an Isco Power Supply, Battery Charger, or Five-Station Battery Charger. All supply the proper DC charging current. Chargers designed for lead-acid batteries, are usually not satisfactory because their open-circuit voltage is generally too low to fully charge a nickel cadmium battery; consequently they are not recommended. To charge a nickel-cadmium battery, connect the plug on the battery cable to the mating receptacle on the power pack or to the connector on the battery charger.

Because the nickel-cadmium battery shows an almost constant output voltage regardless of state-of-charge, voltage measurements are of little or no value. We recommend that you leave the nickel-cadmium battery on charge for 15 to 18 hours. While charging, the battery will stay cool to the touch. When charged, it will feel

warm, as the charging current turns into heat. Quit charging when the battery feels warm. You can achieve the 15–18 hour charging period by putting the batteries on charge at 5:00 PM and removing them at 8:00 AM the next morning.

4.5.2 Five-Station Battery Charger

If you have several flow meters or samplers and must maintain a large number of nickel-cadmium batteries, Teledyne Isco offers a five-station battery charger, which can charge up to five nickel-cadmium batteries or five lead-acid batteries at the same time. The Five-Station Battery Charger operates from the 120 VAC line and provides five separate 400 mA current-limited outputs to charge the batteries. A switch lets you select charging for either lead-acid or nickel-cadmium batteries.

4.5.3 Self-Discharge Characteristics

After you recharge a nickel-cadmium battery, return it to service as quickly as possible (one to two weeks maximum) to ensure you have a fully-charged battery. These batteries have higher self-discharge characteristics than others. Unlike non-rechargeable “primary” batteries (such as alkalines or lithium) that hold most of their charge for several years, a fully-charged nickel-cadmium battery will discharge itself completely in a matter of months. This does not affect the life of the batteries, and does not mean the battery is

defective. (Lead-acid batteries also lose their charge, but over a much longer time; typically 50% in one year at room temperature. However, lead acid batteries are usually ruined if they are allowed to self-discharge completely.)

The charge on the nickel-cadmium battery will not last as long as expected if you delay using it for several weeks. The self-discharge characteristic increases as the temperature increases—always store the batteries in a cool area. It also gets worse as the batteries age. Self-discharge should not be a problem if you have only one flow meter and two batteries. If you have several instruments and many batteries to maintain, consider numbering them and keeping a log. Then cycle the batteries in order after charging. Or, if you are in doubt about the charge, just recharge the battery again for a few hours before using it.

4.5.4 Hazards of Overcharging

Overcharging the battery causes it to overheat, deteriorating the separator material inside the battery. Repeated overcharging will reduce the useful life of the battery, and should be avoided.

4.5.5 Charging from Another Source

Teledyne Isco does not recommend chargers other than those listed for the nickel-cadmium battery, as you could damage either batteries or charger if they are incompatible. Chargers delivering too much current may overheat the batteries, causing them to vent, releasing

electrolyte. Chargers providing too little current may never fully charge the battery. Do not attempt to use any other charger without an accurate multimeter to monitor the charging current. This should not exceed 450 mA. Be sure of proper polarity before connecting any other equipment. If you use an Isco charger, you can overcharge the battery with little risk. However, you should avoid repeated overcharging.

4.5.6 Internal Fuse

To prevent risk of fire and burns in case of a short-circuit, the nickel-cadmium battery is internally fused at approximately 50 amperes. Refer to the Power Products Guide for information on changing the fuse.

 CAUTION
--

Do not test nickel-cadmium batteries for charge by “sparking” the output, and be very careful in putting voltmeter probes into the output connector. Any accidents resulting in a shorted output will damage the battery in less than three seconds.

4.5.7 Using the Lead-Acid Battery

Teledyne Isco also offers the Lead-Acid Battery. Made with a gelled-electrolyte battery, this power source differs from the nickel-cadmium battery in behavior and charging requirements. Please note the following:

1. Do not let the battery discharge completely before recharging; total discharge of

- gelled-electrolyte batteries may lead to internal cell reversal. This will ruin the battery.
2. Recharge the battery promptly. Batteries left discharged may not recharge to full capacity, and eventually will not hold a charge at all, due to sulfation of the plates.
 3. Avoid using the battery in subfreezing environments. A discharged battery may freeze in a cold environment, which will ruin it.
 4. Gelled-electrolyte batteries are easily damaged by overcharging; charge only with proper equipment.

Other types of chargers, even those intended for lead-acid batteries, may seriously overcharge these batteries. Proper charging is accomplished by a constant voltage—tapered current technique, rather than by the constant current method used by nickel-cadmium battery chargers. Do not rely on battery temperature as an indicator of charge. If you use an Isco Power Supply, use the charging table printed on the side of the battery or monitor the charging voltage with a reliable digital voltmeter and discontinue charging when the meter reads 14.5 VDC. In remote locations, the Solar Panel Battery Charger can maintain the charge on a Lead-Acid Battery.

4.5.8 Using Other Types of Batteries

A deep-cycle marine/RV battery is suitable for powering the flow meter. However, you must mount this type of battery externally, as it is too large to mount on the flow meter. Teledyne Isco offers a special cable to connect the flow meter to an external battery. Mount the battery securely, in an upright position, so it will not tip over. Do not check the charge condition of lead-acid batteries by “sparking” the output cables (momentarily shorting the wires together). These batteries, when fully charged, can deliver enormous current into a short-circuit, particularly if the short is near the battery. Unlike nickel-cadmium batteries, as a rule lead-acid batteries (gelled or wet cells) are not internally fused.



WARNING

Danger of personal injury! Do not short the battery. Shorted cables can weld together, causing heavy current flow until the wires melt through. The insulation will also melt and burn, particularly if it is thermoplastic. Fire, severe burns to your hands, and the release of toxic fumes are all possible from such an accident.

4.5.9 Attaching the Battery

To use these batteries, plug the connector on the battery cable into the +12 VDC connector of the flow meter. Connect the leads on the cable to the positive and negative terminals of the battery. The positive lead on the cable has red

heat-shrink tubing on the clip. Use corrosion-preventing washers on the battery terminals to slow the battery acid attacking the connections and damaging the connect cable. (These washers are available from any auto parts supply house.)



CAUTION

Be sure of proper polarity before attaching clips to the battery. NEVER attach the flow meter to a source of unknown polarity or voltage. If in doubt, check with a reliable DC voltmeter. NEVER attach the flow meter directly to an AC power source of any voltage under any circumstances. Failure to observe this warning may result in serious damage to the electrical components of the flow meter.

4.6 Regenerating the Desiccator

The Model 4210 has a reusable desiccant canister inside the case. The canister contains silica gel that takes up moisture inside the case when closed, keeping the unit dry during shipment, storage and use. If you leave the case open, the canister will take up moisture from the air. It will become saturated and will no longer protect the flow meter.

4.6.1 Regenerating the Internal Case Desiccant

Look at the desiccant canister whenever the case is opened. The canister has a mica window on its side which shows blue or yellow when the desiccant is in good condition. As the canister

absorbs moisture, the window will look pink or green. When pink or green, the desiccant needs regenerating, or replace it with the spare canister in the accessory package. Remove the canister by loosening the two thumbscrews which secure the mounting bracket. Remove the canister and heat it in a vented oven at 300°F (150°C) for about three hours, or until the blue or yellow color returns. Do not use a microwave oven. After cooling, reinstall the canister in the flow meter. Make sure the window on the side of the canister remains visible.



CAUTION

Regeneration of the desiccators is very important. Moisture will gradually be drawn inside the unit, unless the case is nearly always closed. Gases present in most sewer environments can combine with moisture to form acids that can attack both mechanical and electronic components inside the flow meter. This can do serious damage to the flow meter.

- For maximum equipment life and reliability, inspect and regenerate the desiccators regularly.
- There have been reports of noxious fumes coming from the desiccant during regeneration.
- Use a vented oven in a well-ventilated room. Do not remain in the room while the regeneration is taking place.