

# Solinst® 1.66" Double Valve Pump Operating Instructions

Model 408 SS 1.66" dia.

## Operating Principles

When the Solinst Double Valve Pump (DVP) is placed in a well or borehole, water rises inside the pump and the twin tubes to static level. A Control Unit is used to deliver compressed gas to the pump. During the drive period the gas pushes down on the water column contained in the drive line tubing, closing the check valve at the base of the pump. This forces water up the sample line tubing.

A vent period, during which the gas is released, allows hydrostatic pressure to refill the pump and drive line with sample water. The top check valve prevents water in the sample line from falling back into the pump body. This pressurization and vent cycle is repeated manually or automatically as set by the timers on the Control Unit. The cycle may be regulated for purging or sampling.

## Pump Assembly

**Portable:** The Double Valve Pump is assembled by connecting it to skip-bonded, dual 1/4" OD tubing, mounted on a reel.

- To accommodate the 1/4" drive tubing, insert the 1/4" compression adaptor into the 3/8" drive line fitting on the Pump. The 3/8" fitting nut may have to be loosened first, then tightened after the 1/4" adaptor is inserted (see overleaf).
- Push the tubing inserts into the end of the tubing and into the drive and sample compression fittings of the DVP (the nut of the compression fittings may have to be loosened before inserting the tubing). Tighten the nut 1-1/4 turns past finger tight for proper seal (see overleaf).
- Lower the assembled DVP into the well, using a stainless steel safety line connected to the eye bolt on the pump. The Solinst Model 103 Tag Line can be used for this purpose.
- Connect the supply line with the in-line dryer from the compressed gas source to the Control Unit. The drive line connects from the Control Unit to the reel (drive and supply lines come with the Model 464 Control Unit).
- Attach a short (3 ft. or 1 m) length of 1/4" OD sample line to the sample connector on the reel.

**Dedicated:** The Double Valve Pump is assembled by connecting to a Dedicated Wellhead with 3/8" or 1/4" OD sample and drive line tubing.

- Cut the tubing to desired lengths. See steps a) and b) above for tubing connection instructions to the Pump. The 1/4" compression adaptor for the drive line fitting on the Pump can be used if 1/4" drive line tubing is desired.
- Attach the sample and drive lines to the appropriate push fittings on the underside of the Wellhead (see diagram at right for use of push fittings and adaptors).
- Lower the DVP into the well, using a stainless steel safety line if desired. If useful, attach the safety line to the suspension hook on the underside of the Wellhead. Push the Wellhead firmly onto the riser casing.
- Attach a short (3 ft. or 1 m) length of 1/4" OD or 3/8" OD sample line to the sample connector on the Wellhead (see diagram at right for use of push fittings and adaptors).
- Connect the supply line with the in-line dryer from the compressed gas supply to the Control Unit. The drive line connects from the Control Unit to the top of the Wellhead (drive and supply lines come with the Model 464 Control Unit).

For detailed pumping instructions, please see the Solinst Model 464 Control Unit Operating Instructions.

- Notes:**
- The maximum lift for stainless steel pumps is 500 ft. (150 m).
  - DO NOT exceed an operating pressure of 250 psi.
  - The pump has been decontaminated before leaving Solinst however, you may wish to decontaminate your pump before use. The pump should be decontaminated between wells.
  - Tube fittings are based on use of 3/8" drive line and 1/4" sample line. A 3/8" to 1/4" adaptor is also supplied, if dual 1/4" tubing is preferred, or when using a portable reel.

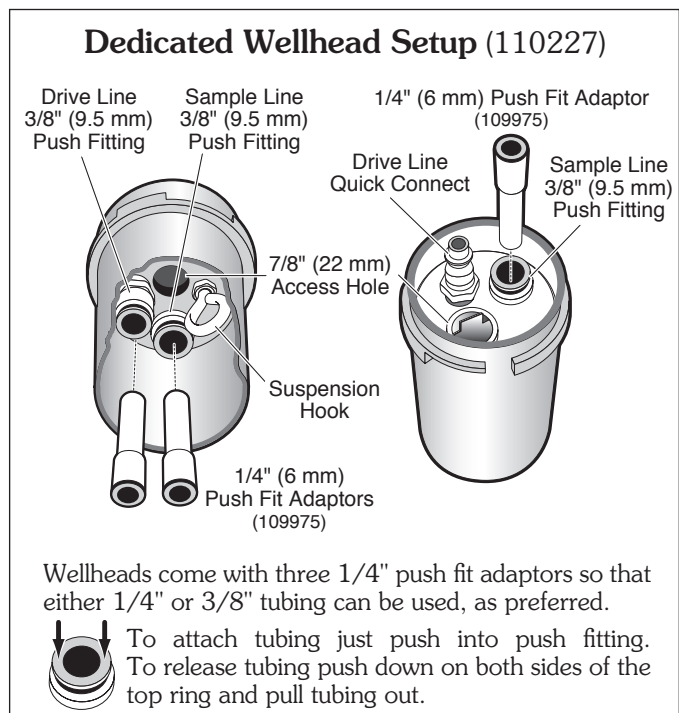
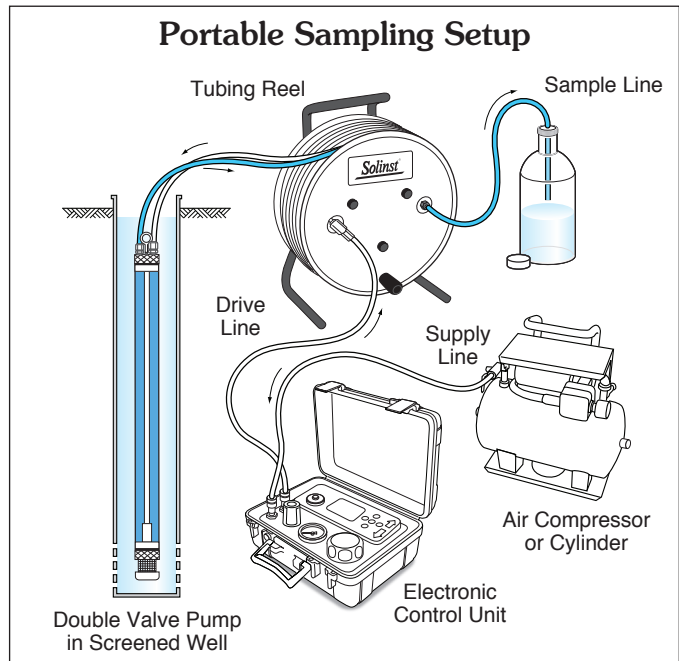

### Pump Tubing Connections

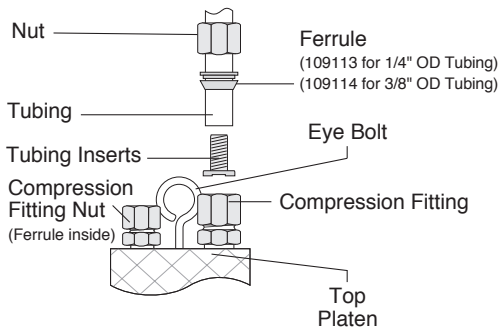

**Note:** Be careful not to lose the two pieces of the ferrule if loosening or removing the nut from the compression fitting.

### Disassembly

1. Remove the Top Platen from the Pump Body and Riser. Remove the Pump Body from the Bottom Platen and slide it off the Riser.
2. Remove the Riser from the Valve Body, being careful not to lose the Check Ball.
3. Remove the Valve Body from the Bottom Platen, being sure not to lose the second Check Ball.
4. Remove the Filter Retainer from the Bottom Platen, and then remove the Filter Mesh from the Filter Retainer.

### Decontamination

**Note:** 1. Always follow your local guidelines and standard protocols.  
2. Do not use acetone on the O-rings.

1. Completely disassemble the pump.
2. Wash all pump components with phosphate-free soap or a detergent.
3. Rinse all components thoroughly with deionized water and dry.
4. Replace worn O-rings as necessary, and then reassemble.

### Reassembly

1. Slide the Filter Mesh over the Filter Retainer until seated.
2. Thread the Bottom Platen onto the Filter Retainer until the O-ring is seated and the parts are finger tight.
3. Insert a Teflon® Check Ball into the top of the Bottom Platen.
4. Take the Valve Body and insert into the Bottom Platen until the O-ring firmly seats.
5. Insert a Teflon Check Ball into the top of the Valve Body.

### 1.66" SS Double Valve Pump

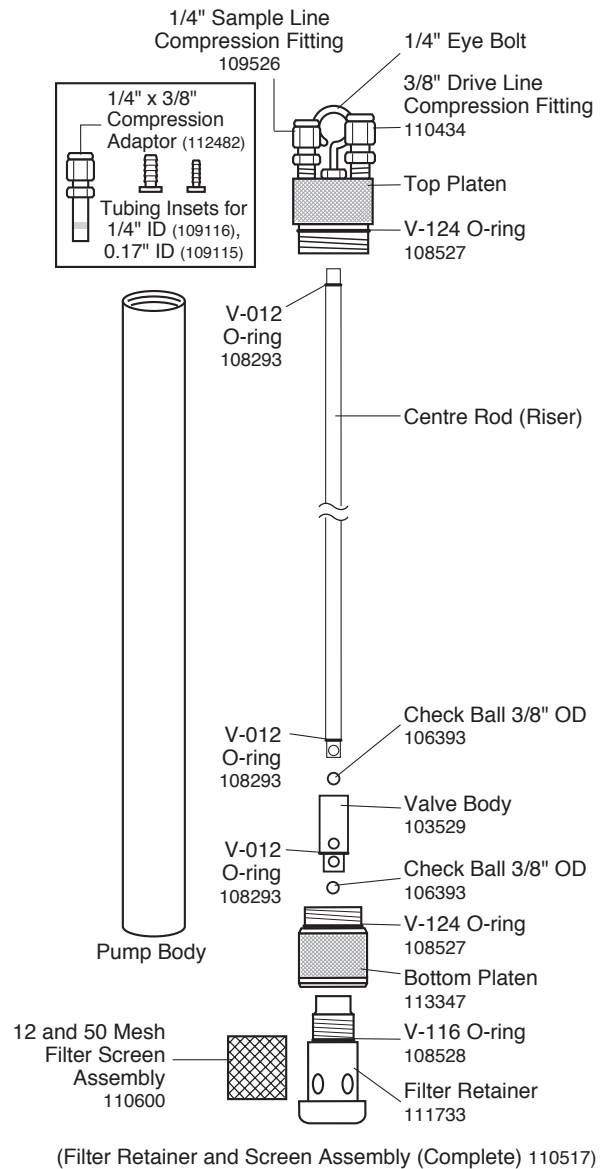

6. Insert the bottom end of the Riser (hole downward) into the Valve Body.
7. Slide the Pump Body over the Riser and thread onto the Bottom Platen.
8. Take the Top Platen and while lining up the top of the Riser into the centre of the Top Platen, thread the Pump Body to the Top Platen.