

Note: 800M Packers are designed for short term applications inside nominal 2" OD wells. However, if longer continuous usage is necessary, daily monitoring of target inflation pressure and packer seal will likely be required.

Single Point Packer: Installation & Inflation

Model 800M Mini Pneumatic Packers are inflated with air via 1/8" (3.2 mm) OD tubing extending from the packer to the surface. A manual hand pump with a gauge may be used to inflate the packer. Please read through these instructions fully before proceeding.

1. Cut an appropriate length of 1/8" (3.2 mm) O.D. inflation tubing to extend from the packer to the surface. This tubing must extend to the surface with enough slack to allow ease of inflation.



2. Push the top end of the inflation tubing into the push fitting on the inflation valve (to release tubing push down on both sides of the fitting and pull tubing out).
3. Push the other end of the inflation tubing into the push fitting on the top of the packer (to release tubing push down on both sides of the fitting and pull tubing out).
4. The system is now complete and can lowered into position using a support cable attached to the eyebolt. The Solinst Model 103 Tag Line can be used, providing an exact measured depth of deployment.

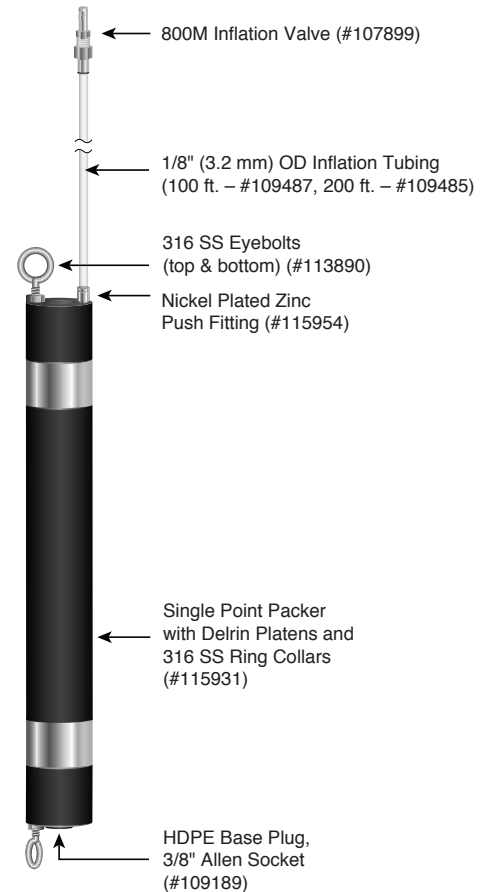

Standard Single Point Packer Setup with Inflation Line
(Inflation Tubing and Valve Not Included with Packer)

800M Packer Specifications (Single Point and Straddle Packers)

Borehole Size and Inflation Pressures	
Borehole Size	1.9 - 2.1" (48 - 53 mm)
Inflation Pressure	20 - 30 psi, 140 - 205 kPa
Notes: 1. <u>Inflation pressures</u> must be added to hydrostatic pressure at the packer location. 2. <u>Maximum depth</u> from surface = 275 ft (84 m) 3. <u>Maximum submergence</u> = 150 ft (46 m) 4. <u>Maximum pressure</u> = 30 psi or 205 kPa over hydrostatic pressure. (1 ft water = 0.43 psi, 1 m water = 9.8 kPa) eg: Required pressure for: Packer placed 100 ft (30 m) below water • Packer in 2" well: 20 psi minimum + (100 ft x 0.43 psi/ft) = 20 + 43 = 63 psi. (46 mm packer: 140 kPa minimum + (30 x 9.8 kPa/m) = 140 + 294 = 434 kPa)	

800M Packer Specifications	
Packer Size OD	1.8" (46 mm)
Access ID	1/2" (12.7 mm)
Gland Length	7" (178 mm)
Overall Length	12" (305 mm)
Weight	0.5 kg (1.2 lbs)
Borehole Size	1.9 - 2.1" (48 - 53 mm)
Pipe Fittings	1/2" NPT Female
1/8" OD LDPE Inflation Line	100 ft (#109487), 200 ft (#109485)

Straddle Packer: Installation & Inflation

Model 800M Mini Pneumatic Packers are inflated with air via 1/8" (3.2 mm) OD tubing extending from the packer to the surface. A hand pump with a gauge may be used to inflate the packer. Please read through these instructions fully before proceeding.

Straddle Packer: Assembly & Tubing Connection

1. To assemble the Straddle Packer system, connect the lower and upper packers with a suitable length of 1/2" NPT perforated (straddle) pipe.
2. Attach a length of 1/8" (3.2 mm) inflation line between the top of the lower packer and the bottom of the upper packer. Simply push the tubing into the push fittings (to release tubing push down on both sides of the fitting and pull tubing out).

Note: The lower packer of the Straddle Packer system has only one inflation line fitting.

3. Cut an appropriate length of 1/8" (3.2 mm) O.D. tubing to extend from the top packer to the surface with enough slack to allow ease of inflation.
4. Push the top end of the inflation tubing into the push fitting on the inflation valve (to release tubing push down on both sides of the fitting and pull tubing out).
5. Push the other end of the inflation tubing into the push fitting on the top of the packer (to release tubing push down on both sides of the fitting and pull tubing out).
6. The system is now complete and should be installed by connecting the appropriate length riser pipe and lowering the system into the well.

Note: If connecting to a Solinst Model 415 12V Pump, Model 407 Bladder Pump or Model 408 Double Valve Pump to the top of the Packer setup, you will not require a riser pipe, but a safety cable or Solinst Tag Line can be attached to the Pump or Packer eyebolt.

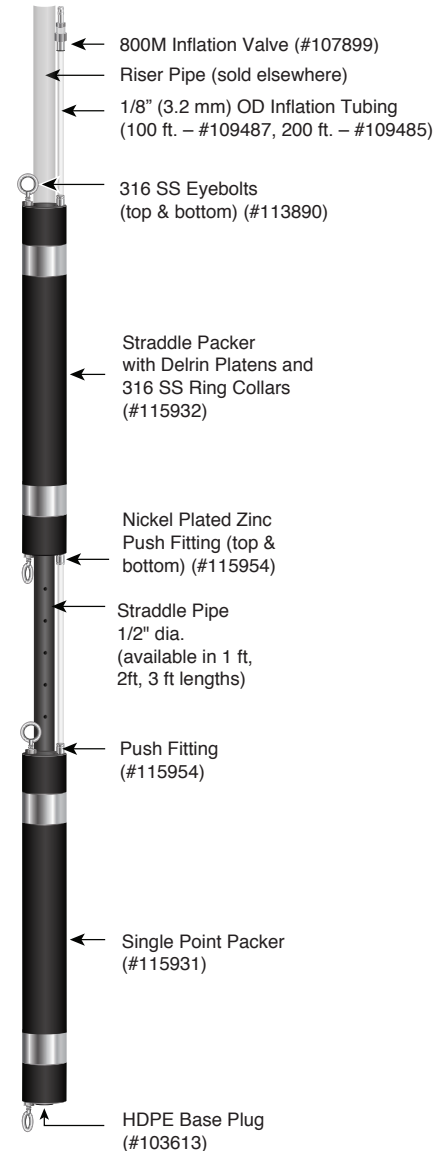

Standard Straddle Packer Setup with Inflation Lines
(Inflation Tubing and Valve Not Included with Packer)