

Single Point Packer: Installation & Inflation

Model 800 Pneumatic Packers are inflated with air via 1/4" (6.4 mm) O.D. tubing extending from the packer to the surface. A manual hand pump with a gauge may be used to inflate the packer. Please read through these instructions fully before proceeding.

Note: Figures A and B (found overleaf) illustrate centralizer installation for both Single Point and Straddle Packers. For packer specifications, borehole sizes and required inflation pressures, please refer to the charts below.

1. Cut an appropriate length of 1/4" (6.4 mm) O.D. inflation tubing to extend from the packer to the surface. This tubing must extend to the surface with enough slack to allow ease of inflation.
2. Push the top end of the inflation tubing into the push fitting on the inflation valve (to release tubing push down on both sides of the fitting and pull tubing out).
3. Connect the other end of the inflation tubing to the packer. Push the tubing onto the stainless steel barb fitting. Check the connection by pulling firmly on the tubing. It should not pull off of the fitting.

Note: Use an awl to open the very tip of the tubing, or heat the tubing to help push it completely over all the barbs.

4. The system is now complete and should be installed by connecting the appropriate riser pipe and lowering the system into the well. Hang the riser pipe such that the packer is suspended at the appropriate depth.
5. If a riser pipe is not used, then a safety cable should be attached to the eyebolt on the packer to allow securing at surface. The Solinst Tag Line can be used for this purpose. (See Model 103 Data Sheet.)

Note: All Model 800 Packers are designed for short term applications. However, if longer continuous usage is necessary, weekly monitoring of target inflation pressure and packer seal will be required.



Inflation Valve

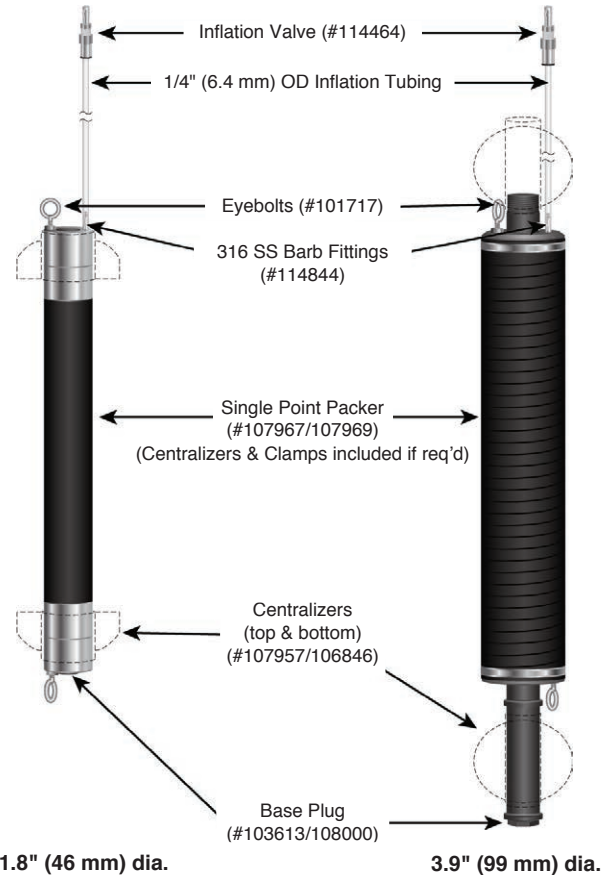

1.8" (46 mm) dia.

3.9" (99 mm) dia.

Standard Single Point Packer Setup with Inflation Lines

800 Packer Specifications (Single Point and Straddle Packers)

Packer	1.8" O.D. (46 mm)	3.9" O.D. (99 mm)
Well Size	1.9 - 2.4" (48 - 61 mm)	4.0 - 4.4" (102 - 112 mm)
Inflation Pressure	20 - 30 psi, 140 - 205 kPa	20 psi, 140 kPa
With Centralizers (trim to fit)		
Well Size	2.5 - 3.5" (63 - 89 mm)	4.5 - 5.0" (114 - 127 mm)
Inflation Pressure	35 - 40 psi, 240 - 275 kPa	25 - 30 psi, 170 - 205 kPa
Notes: 1. <u>Inflation pressures</u> must be added to hydrostatic pressure at the packer location. 2. <u>Maximum depth</u> from surface = 275 ft (84 m) 3. <u>Maximum submergence</u> = 150 ft (46 m) 4. <u>Maximum pressure</u> for 1.8" (46 mm) packer, = 50 psi or 345 kPa over hydrostatic pressure. Maximum pressure for 3.9" (99 mm) packers = 30 psi or 205 kPa over hydrostatic pressure. (1 ft water = 0.43 psi, 1 m water = 9.8 kPa) eg: Required pressure for: Packer placed 100 ft (30 m) below water • 1.8" packer in 2" well: 20 psi minimum + (100 ft x 0.43 psi) = 20 + 43 = 63 psi. (46 mm packer: 140 kPa minimum + (30 x 9.8 kPa) = 140 + 294 = 434 kPa)		

Specifications		
Borehole Size	1.9 - 2.4" (48 - 61 mm)	4.0 - 4.4" (102 - 112 mm)
-with centralizers (trim to fit)	2.5 - 3.5" (63 - 89 mm)	4.5 - 5.0" (114 - 127 mm)
Packer Size OD	1.8" (46 mm)	3.9" (99 mm)
Access ID	1/2" (12.7 mm)	1" (25.4 mm)
Gland Length	23" (584 mm)	30" (762 mm)
Overall Length	29" (737 mm)	36" (914.4 mm)
-with centralizers	29" (737 mm)	44" (1117.6 mm)
Pipe Fittings	1/2" NPT - Female	1" NPT - Male
-with centralizers	1/2" NPT - Female	1" NPT - Female

Straddle Packer: Installation & Inflation

Model 800 Pneumatic Packers are inflated with air via 1/4" (6.4 mm) OD tubing extending from the packer to the surface. A hand pump with a gauge may be used to inflate the packer. Please read through these instructions fully before proceeding.

Straddle Packer: Assembly & Tubing Connection

1. To assemble the Straddle Packer system, connect the lower and upper packers with a suitable length of screen or perforated pipe (1/2" NPT for 1.8" (46 mm) or 1" NPT for 3.9" (99 mm) packers).

To connect 3.9" (99 mm) packers, you will also need to use a PVC bushing, and the NPTF coupling that comes with the perforated straddle pipe (see diagram).

2. Attach a length of 1/4" (6.4 mm) inflation line between the top of the lower packer and the bottom of the upper packer. Simply push the tubing onto the stainless steel barb fittings.

Note: Use an awl to open the very tip of the tubing, or heat the tubing to help push it completely over all the barbs.

3. Cut an appropriate length of 1/4" (6.4 mm) O.D. tubing to extend from the top packer to the surface with enough slack to allow ease of inflation.
4. Push the top end of the inflation tubing into the push fitting on the inflation valve (to release tubing push down on both sides of the fitting and pull tubing out).
5. Connect the other end of the inflation tubing to the packer. Push the tubing onto the stainless steel barb fitting. Check the connection by pulling firmly on the tubing. It should not pull off of the fitting.
6. The system is now complete and should be installed by connecting the appropriate riser pipe and lowering the system into the well.
7. If a riser pipe is not used, then hang the packer with a wireline to suspend at the appropriate depth. A safety cable should be attached to the eyebolt on the packer to allow securing at surface, and between each packer. The Solinst Tag Line can be used for this purpose.

Note: The lower packer of the Straddle Packer system has only one inflation line fitting.

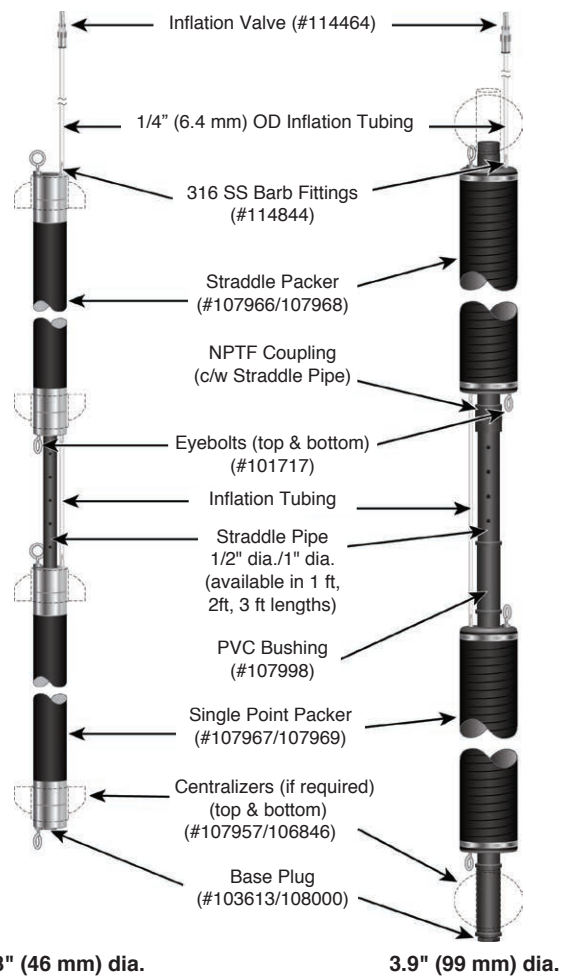

Standard Straddle Packer Setup with Inflation Lines

Note: Figures A and B illustrate centralizer installation for both Single Point and Straddle Packers. For packer specifications, borehole sizes and required inflation pressures, please refer to the charts overleaf.

800 Packer Centralizer Installation (Single Point and Straddle Packers) – trim to fit borehole

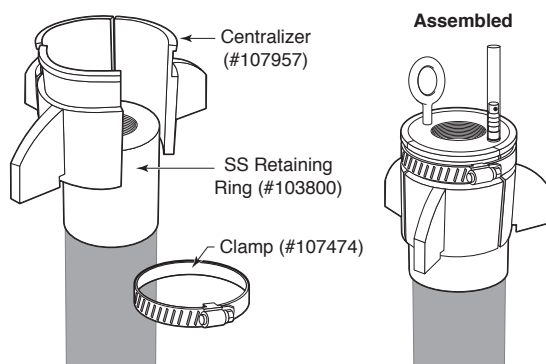

Figure A - 1.8" (46 mm) Centralizer Assembly

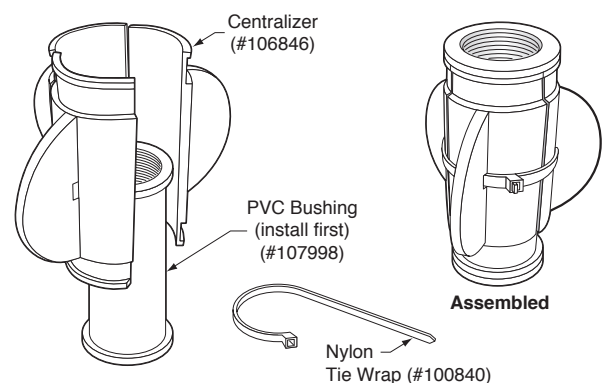

Figure B - 3.9" (99 mm) Centralizer Assembly