

Moisture

 Panametrics

# DewPro<sup>®</sup> MMR31

## Installation & Operation Manual





Moisture



# DewPro<sup>®</sup> MMR31

***Moisture Transmitter  
(Mid-Range, 1 or 2 Current Loops)***

## Installation & Operation Manual

A40251532 Rev.C  
July 2020

[panametrics.com](http://panametrics.com)

Copyright 2020. Baker Hughes company.

This material contains one or more registered trademarks of Baker Hughes Company and its subsidiaries in one or more countries. All third-party product and company names are trademarks of their respective holders.

[no content intended for this page]

---

## Information Paragraphs

**Note:** *These paragraphs provide information that provides a deeper understanding of the situation, but is not essential to the proper completion of the instructions.*

**IMPORTANT:** These paragraphs provide information that emphasizes instructions that are essential to proper setup of the equipment. Failure to follow these instructions carefully may cause unreliable performance.



**CAUTION!** This symbol indicates a risk of potential minor personal injury and/or severe damage to the equipment, unless these instructions are followed carefully.



**WARNING!** This symbol indicates a risk of potential serious personal injury, unless these instructions are followed carefully.

## Safety Issues



**WARNING!** It is the responsibility of the user to make sure all local, county, state and national codes, regulations, rules and laws related to safety and safe operating conditions are met for each installation. The safety of any system incorporating the equipment is the responsibility of the assembler of the system.

## Auxiliary Equipment

### Local Safety Standards

The user must make sure that he operates all auxiliary equipment in accordance with local codes, standards, regulations, or laws applicable to safety.

### Working Area



**WARNING!** Auxiliary equipment may have both manual and automatic modes of operation. As equipment can move suddenly and without warning, do not enter the work cell of this equipment during automatic operation, and do not enter the work envelope of this equipment during manual operation. If you do, serious injury can result.



**WARNING!** Make sure that power to the auxiliary equipment is turned OFF and locked out before you perform maintenance procedures on the equipment.



**WARNING!** It is the responsibility of the user to make sure the PWR, Hart, Modbus and I/O cable can meet the cable specification, which is described in Appendix A.

## Qualification of Personnel

Make sure that all personnel have manufacturer-approved training applicable to the auxiliary equipment.

---

## Personal Safety Equipment

Make sure that operators and maintenance personnel have all safety equipment applicable to the auxiliary equipment. Examples include safety glasses, protective headgear, safety shoes, etc.

## Unauthorized Operation

Make sure that unauthorized personnel cannot gain access to the operation of the equipment.

## Environmental Compliance

### Waste Electrical and Electronic Equipment (WEEE) Directive

Panametrics Measurement & Control is an active participant in Europe's *Waste Electrical and Electronic Equipment (WEEE)* take-back initiative, directive 2012/19/EU.



The equipment that you bought has required the extraction and use of natural resources for its production. It may contain hazardous substances that could impact health and the environment.

In order to avoid the dissemination of those substances in our environment and to diminish the pressure on the natural resources, we encourage you to use the appropriate take-back systems. Those systems will reuse or recycle most of the materials of your end life equipment in a sound way.

The crossed-out wheeled bin symbol invites you to use those systems.

If you need more information on the collection, reuse and recycling systems, please contact your local or regional waste administration.

Visit <https://www.gemeasurement.com/environmental-health-safety-ehs> for take-back instructions and more information about this initiative.

## Chapter 1. General Information

1.1	Unpacking and Inspection	1
1.2	Model Number	1
1.3	Version Descriptions	2
1.4	Theory of Operation	3
1.4.1	First 4–20 mA Loop	3
1.4.2	Second 4–20 mA Loop	3
1.4.3	Polymer Sensor	3
1.4.4	Calibration	3

## Chapter 2. Installation

2.1	Mounting the MMR31	5
2.1.1	Using a Compression Fitting or a Flange	5
2.1.2	Using a Bracket	7
2.2	Wiring Configurations with One Current Loop	8
2.2.1	General Guidelines	8
2.2.2	Normal Environments	9
2.2.3	Environments with Severe Electrical Noise	9
2.2.4	General Wiring Instructions	10
2.3	Wiring Configurations with Two Current Loops	11
2.3.1	General Guidelines	11
2.3.2	Normal Environments	12
2.3.3	Environments with Severe Electrical Noise	12
2.3.4	General Wiring Instructions	13
2.4	Selecting the Units of Measure	14

## Chapter 3. Calibration and Troubleshooting

3.1	Calibration Using Two Saturated Salt Solutions	15
3.2	Calibration Steps	16
3.2.1	Calibrating the Low RH Reading	16
3.2.2	Calibrating the High RH Reading	17
3.3	Troubleshooting	18
3.3.1	Loop Current is Out of Range	18
3.3.2	No Loop Current	18
3.3.3	Slow Response Time	18
3.3.4	Frozen Output Current	18

## Chapter 4. Optional Display/User Interface

4.1	Accessing the Programming Buttons	19
4.1.1	Removing the Display	19
4.2	Programming the Matrix	20
4.3	Matrix Buttons – Special Functions	22
4.3.1	Reset to “Normal” Display	22
4.3.2	Display Only	22
4.3.3	Default Values	22
4.4	Matrix Functions	23
4.4.1	System Administration Functions	23
4.4.2	Moisture Measurement Functions	24
4.4.3	4–20 mA Output Range Functions	24
4.4.4	Temperature Measurement Functions	25
4.4.5	Error Codes	26

## Chapter 5. Specifications

5.1	Technical Specifications	29
5.2	Optional Onboard Display with User Interface	30
5.3	EMI/RFI Protection	31
5.4	EMC Compliance	31
5.5	Available Accessories	31





# Chapter 1. General Information

## 1.1 Unpacking and Inspection

Upon receipt of the DewPro MMR31, examine the shipping carton for broken or open packing, distortion, or any other evidence of mishandling. If your inspection indicates damage to the unit or any of its components may have occurred, notify the carrier within 15 days of delivery and request an inspection.

If no shipping damage is suspected, move the carton to a clean work area and unpack the contents. The carton you received should contain:

- DewPro MMR31 Instrument
- Installation and Operation Manual
- Calibration Certificate

## 1.2 Model Number

Locate the product label on your MMR31, and compare the last five characters of the model number with the product numbering structure shown on the next page. This will confirm that your MMR31 has been configured to your specifications.



Figure 1: DewPro MMR31 Product Label

## 1.2 Model Number (cont.)

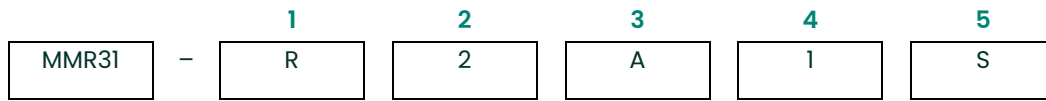

### 1 - Certification

- R. Standard Certification (not certified)
- S. Other

### 2 - Process Connection

- 1. 3" diameter galvanized floor flange with 12.7 mm (½" NPT-M) compression fitting
- 2. ¾" NPT-M compression fitting
- 3. 1/2" NPT-M compression fitting
- 4. ¾" x 16 "O" ring compression fitting (UNF thread)
- 6. No mounting hardware
- 8. G1/2 compression fitting (Male thread), gasket, SS ferrule
- S. Other

### 3 - Protective Cap

- A. Standard, with 100 micron sintered filter
- S. Other

### 4 - Enclosure Conduit

- 1. Enclosure Conduit M20 x 1.5-F with cable gland and plug
- 2. Enclosure Conduit M20 x 1.5-F with 1/2" FNPT adapter and plug
- S. Other

### 5 - Output Configuration/Dewpoint Range

- A. One output 4-20 mA selectable: RH 0-100% or dewpoint 15 to +85°C (5 to 185°F), absolute humidity, mixing ratio, no display, fault status 22 mA
- B. Two 4-20 mA DC output loops: 1st loop Moisture, 2nd loop temperature -15 to +85°C (5 to 185°F), no display, fault status 22 mA
- C. As A, fault status hold
- D. As A, fault status 3.6 mA
- E. As B, fault status hold
- F. As B, fault status 3.6 mA
- G. As A, with integral display, user interface
- H. As B, with integral display, user interface
- S. Other

## 1.3 Version Descriptions

The DewPro MMR31 mid-range moisture transmitter is available in two versions:

- *One isolated 4-20 mA current loop:* The loop current represents the selected *moisture* unit (see "Selecting the Units of Measure" on page 14).
- *Two isolated 4-20 mA loops:* The second loop current represents *temperature*. A unique patented feature of this version is that both loops can be powered by a single supply.

The MMR31 transmitter includes:

- Sensor element
- Stainless steel probe
- Weather-proof enclosure
- Microprocessor electronics

It is designed to be inserted directly into the process. Various mounting hardware, such as flange and compression fittings are available for mounting into a duct, process chamber, wall, etc. The DewPro MMR31 measures relative humidity in %, dew point temperature in °F or °C, absolute humidity in  $\text{g}/\text{m}^3$ , or mixing ratio in  $\text{g}/\text{kg}$ . An optional display with user interface allows the user to configure the MMR31 (see Chapter 4, “Optional Display/User Interface” on page 19).

## 1.4 Theory of Operation

### 1.4.1 First 4–20 mA Loop

The MMR31 microcontroller-operated electronics operates with a voltage supply of 12 to 28 VDC. At the nominal 24 VDC supply, the maximum loop resistance is 600 ohms. The signal is represented by the 4 to 20 mA loop current and is directly proportional to 0 to 100% relative humidity, or, if selected, the dew point temperature range of 5 to 185°F (-15 to +85°C), the absolute humidity in a range of 1 to 350  $\text{g}/\text{m}^3$ , or the mixing ratio in a range of 1 to 830  $\text{g}/\text{kg}$ .

### 1.4.2 Second 4–20 mA Loop

The specifications for the first loop current are also valid for the second loop current, except that the 4 to 20mA signal always corresponds to the temperature range of 5 to 185°F (-15 to +85°C).

### 1.4.3 Polymer Sensor

The sensing element in the MMR31 is a silicon-based polymer that uses the capacitance principle for the moisture measurement. The IC chip includes the moisture sensor and appropriate integrated circuitry. A platinum RTD temperature sensor is built in to provide temperature compensation for maximum accuracy. The sensor element is protected from condensation using a hydrophobic sintered filter. An additional removable filter cap serves as a pre-filter.

### 1.4.4 Calibration

Each MMR31 is factory-calibrated against precise NIST certified moisture references. Field calibration is possible with the use of saturated salt solutions (refer to Chapter 3, “Calibration and Troubleshooting” on page 15).

[no content intended for this page]

## Chapter 2. Installation

To properly install your MMR31, carefully follow the instructions in this chapter.

### 2.1 Mounting the MMR31

To select a suitable mounting location, refer to the dimensions shown in *Figure 2* below.

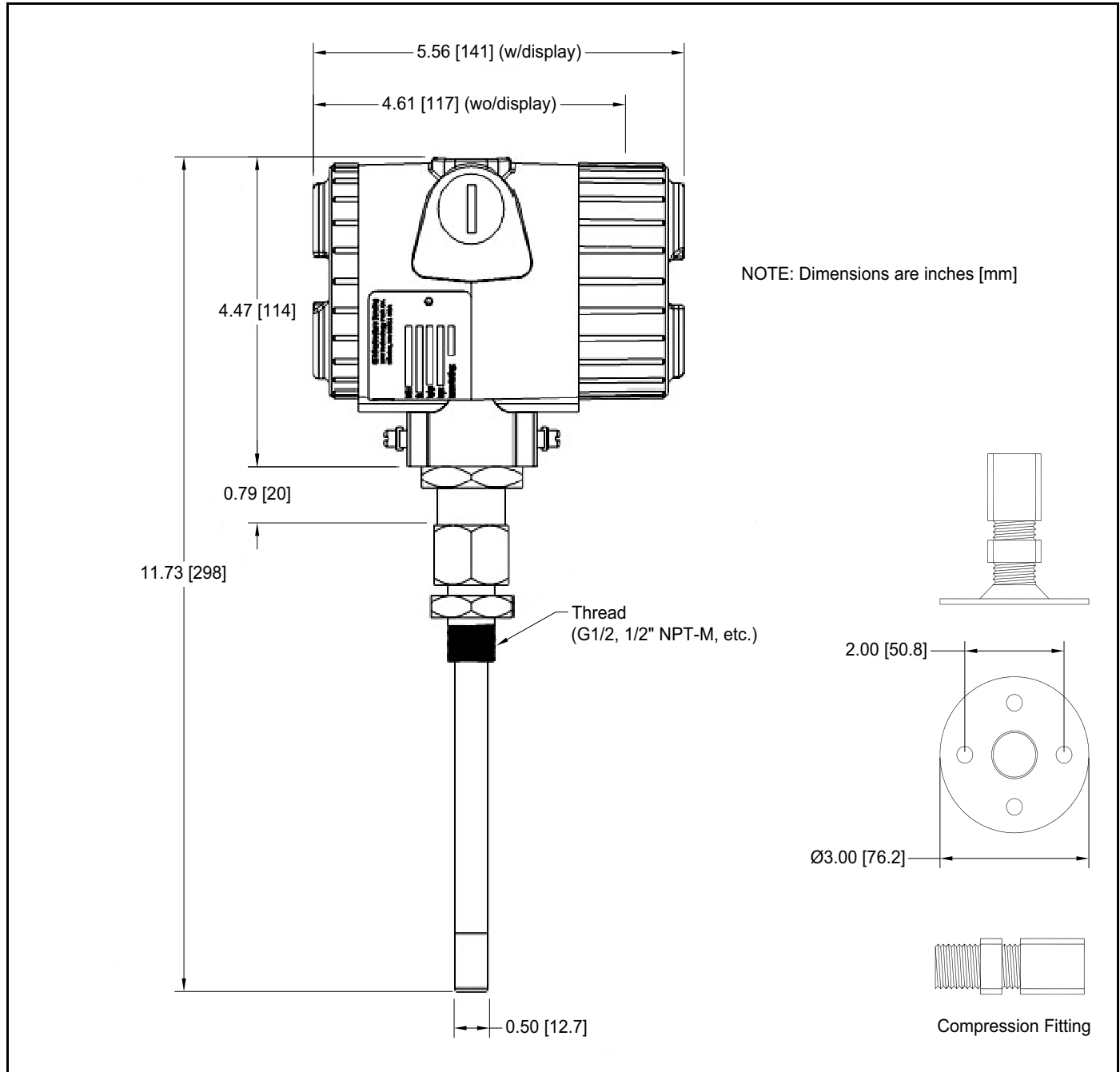

Figure 2: MMR31 and Compression Fitting Dimensions

#### 2.1.1 Using a Compression Fitting or a Flange

**IMPORTANT:** Be certain that the tip of the probe does not touch the inside wall of the pipe or container.

**IMPORTANT:** A 1.4571 stainless steel ferrule is required for use in pressurized systems. Ensure that your probe has the appropriate fitting for your application.

To monitor moisture inside a pipe or container, mount the probe using a compression fitting connection or a flange (see *Figure 3* below). Adjust the ferrule for a probe insertion length of at least 1 in. (25 mm) and tighten the compression fitting as follows:

1. Hand-tighten the nut.
2. Use a wrench to tighten the nut 1-1/2 turns. When tightened in this manner, the fitting with a stainless steel ferrule can withstand pressures up to 17 bar (250 psi).

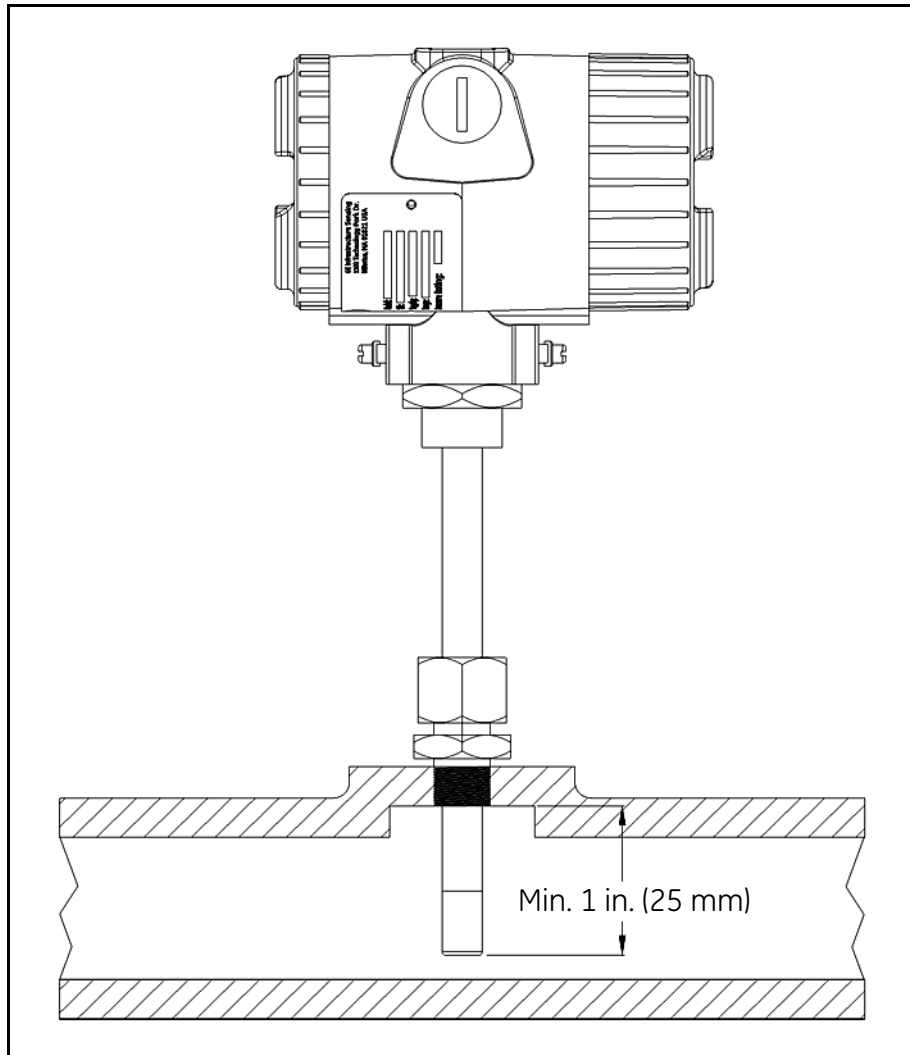

**Figure 3: Mounting the Probe in a Pipe**

## 2.1.2 Using a Bracket

The MMR31 can be used to monitor the air in a room or other such area, by using the available mounting kits shown in *Figure 4* below.

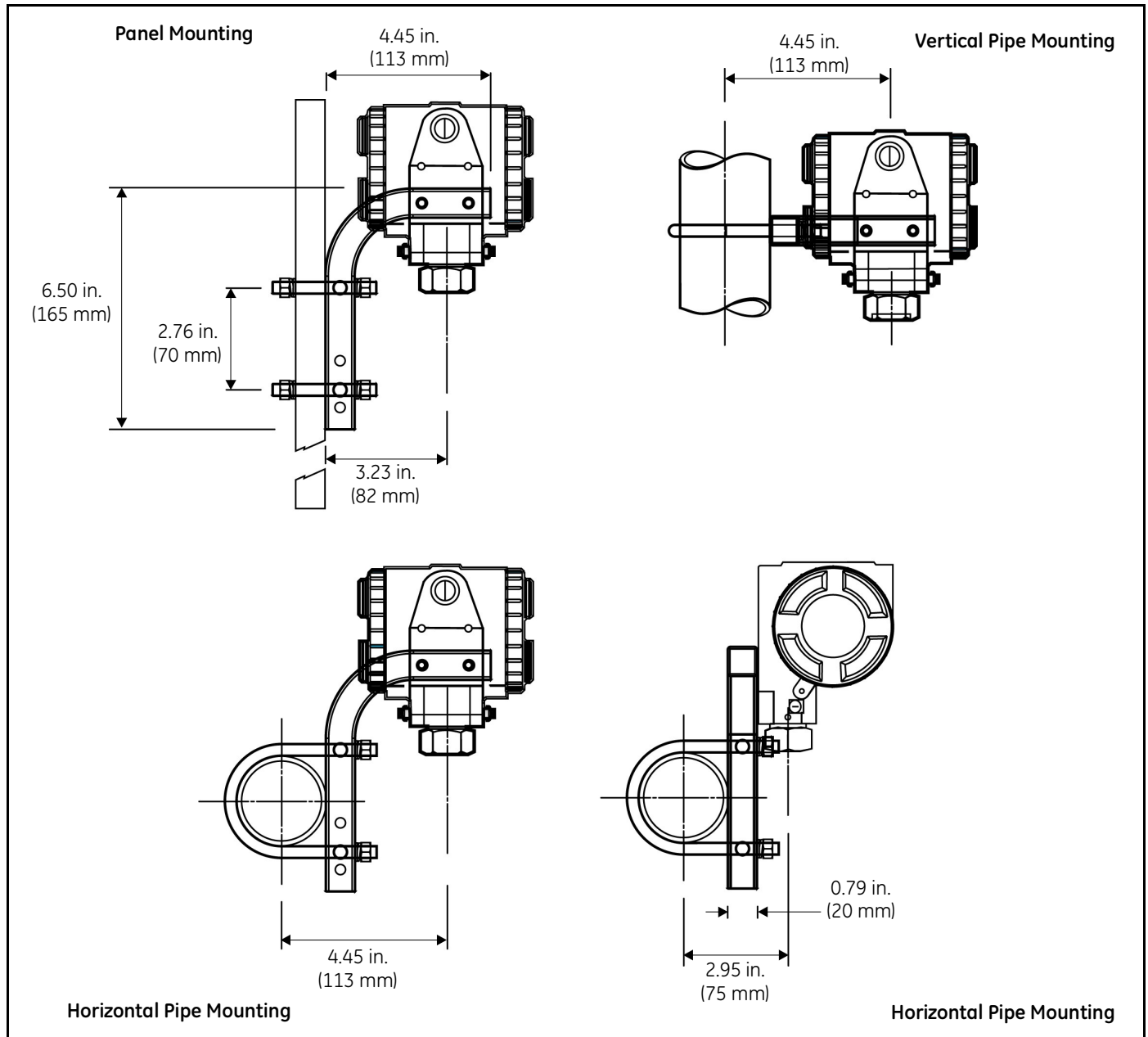

**Figure 4: Mounting Kit Configurations**

## 2.2 Wiring Configurations with One Current Loop



**CAUTION!** The MMR31 system contains electronic components that are susceptible to damage by static electricity. Proper handling procedures must be observed during the removal, installation, or other handling of internal circuit boards.

### 2.2.1 General Guidelines

The maximum loop resistance is an important parameter for selection of the supply voltage, because each device connected to the loop causes a voltage drop. For instance, using a loop-powered display with an input impedance of 50 ohms will cause a voltage drop of 1 VDC at 20 mA, per Ohm's law ( $V = R \times I = 50 \times 0.020 = 1$ ). Similarly, connecting the loop to a Programmable Logic Controller (PLC) will cause a voltage drop across its input.

When designing your loop, add up all voltage drops across the devices connected to the loop and then add 12 V. This sum is the minimum supply voltage required for the circuit. To ensure reliable operation, it is recommended that a 20% safety factor be added to the calculated voltage requirement.

**IMPORTANT:** The voltage across the + and - terminals of the MMR31 should not fall below 12 VDC.

If an external display is used, configure it to the proper range: 0-100% RH, 5 to 185°F (-15 to +85°C) dew point, 1 to 350 g/m<sup>3</sup> absolute humidity, 1 to 830 g/kg mixing ratio, or custom range corresponding to 4-20 mA. *Figure 5* below illustrates some common system configuration options.

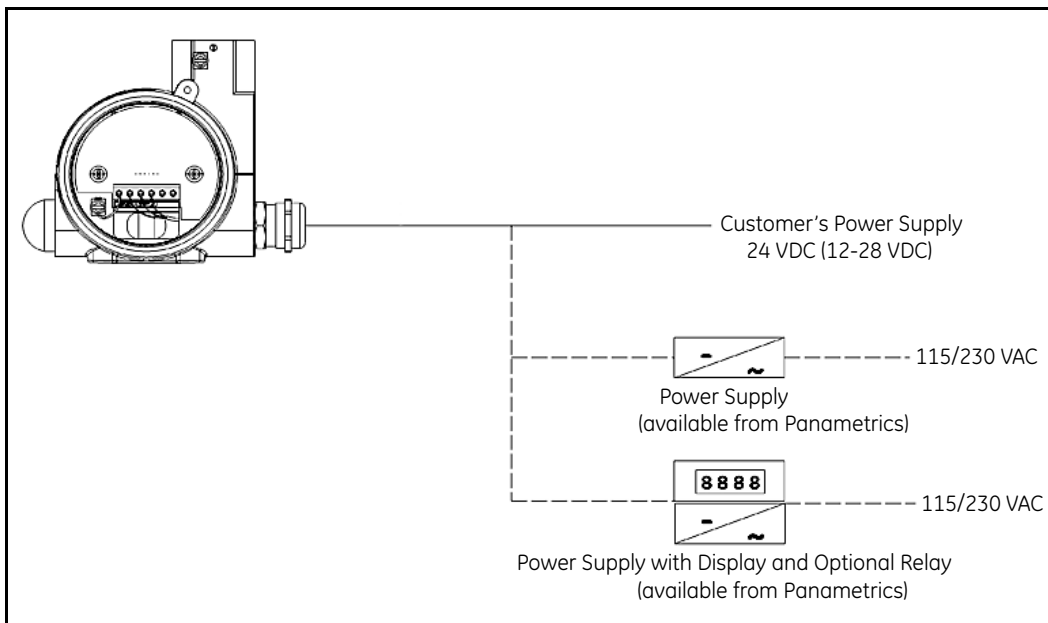

**Figure 5: System Configuration Options**



### 2.2.2 Normal Environments

A standard two-wire, stranded cable can be used in a normal environment to interconnect the MMR31 with its loop power source.

### 2.2.3 Environments with Severe Electrical Noise

When the MMR31 is installed in environments with severe electrical noise, wiring must be done with shielded and grounded cable, as shown in *Figure 6* below. Details of the MMR31 testing and certifications in such environments can be found in Chapter 5, "Specifications" on page 29, and the CE Declaration of Conformity at the end of this manual.

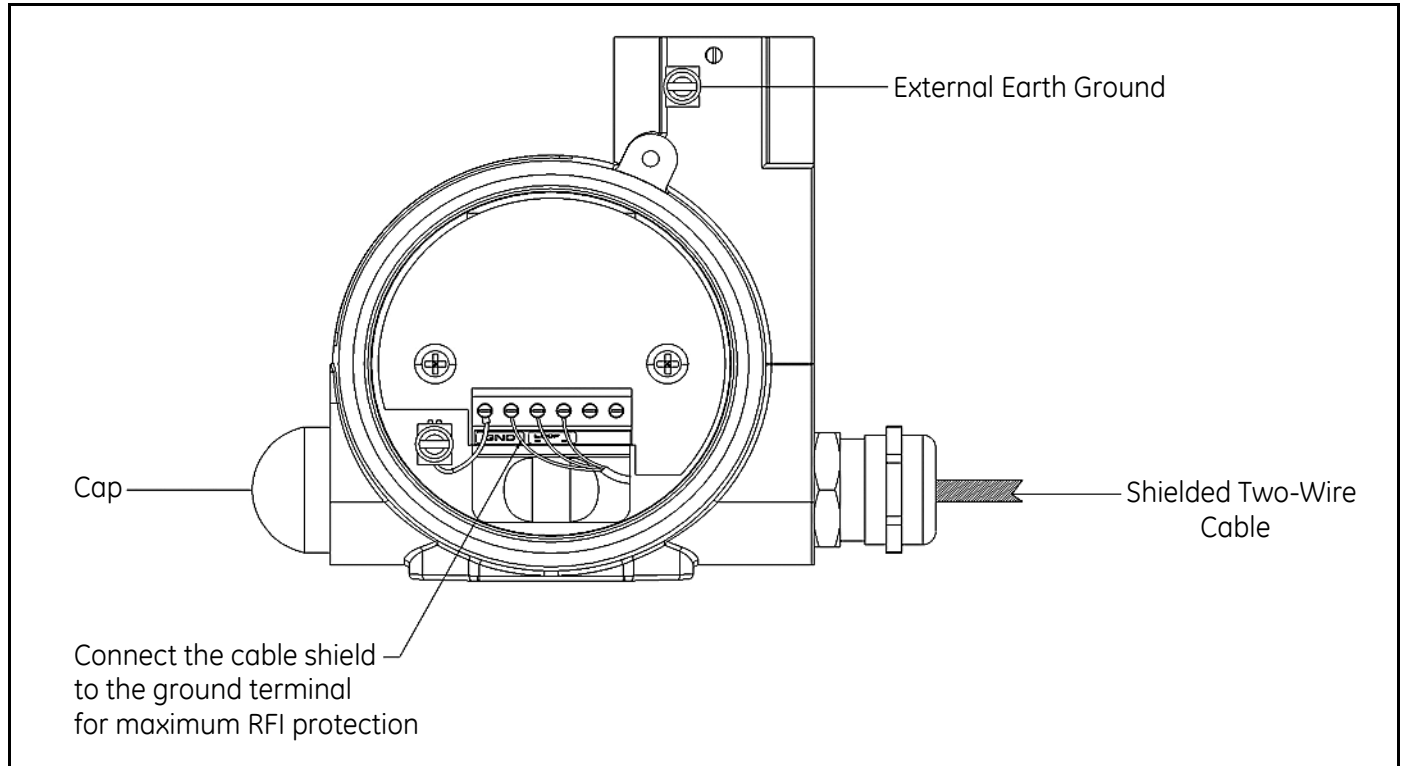

**Figure 6: Shielded Cable Wiring Diagram**

## 2.2.4 General Wiring Instructions

To wire the MMR31, refer to *Figure 7* below and complete the following steps:

1. Unscrew the cap on the terminal side of the unit.
2. Loosen the cable gland located on the side of the unit.
3. Feed the cable through the conduit opening.

**Note:** Use a standard signal cable size.

4. Retighten the metal cable gland to meet IP 67 and to relieve any stress on the wire.
5. Connect the wires to the MMR31 terminals as shown in *Figure 7* below.
6. Verify that a voltage between 12 and 28 VDC is present across the terminals marked + and –.

**Note:** This is the voltage that is actually measured across the MMR31 terminals. It is not necessarily exactly the same as the power supply voltage, due to voltage loss in the wires, displays, indicators, etc.

7. To meet EMI/RFI immunity requirements, a two-wire shielded cable with a common foil shield layer is used to power the MMR31. To clamp the shield foil in the metal cable gland, remove 3 in. (75 mm) of the insulation and fold back the foil. The ground wire must be connected to the internal grounding screw.

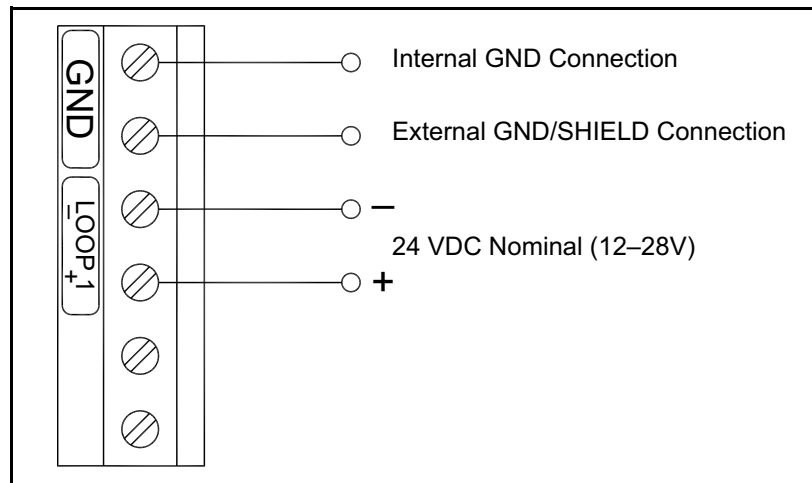

**Figure 7: Electrical Connections - One Current Loop**

## 2.3 Wiring Configurations with Two Current Loops



**CAUTION!** The MMR31 system contains electronic components that are susceptible to damage by static electricity. Proper handling procedures must be observed during the removal, installation, or other handling of internal circuit boards.

### 2.3.1 General Guidelines

The maximum loop resistance is an important parameter for selection of the supply voltage, because each device connected to the loop causes a voltage drop. For instance, using a loop-powered display with an input impedance of

50 ohms will cause a voltage drop of 1 VDC at 20 mA, per Ohm's law ( $V = R \times I = 50 \times 0.020 = 1$ ). Similarly, connecting the loop to a Programmable Logic Controller (PLC) will cause a voltage drop across its input.

When designing your loop, add up all voltage drops across the devices connected to the loop and then add 12 V. This sum is the minimum supply voltage required for the circuit. To ensure reliable operation, it is recommended that a 20% safety factor be added to the calculated voltage requirement.

**IMPORTANT:** The voltage across the + and - terminals of the MMR31 should not fall below 12 VDC.

If an external display is used, configure it to the proper range: 0-100% RH, 5 to 185°F (-15 to +85°C) dew point, 1 to 350 g/m<sup>3</sup> absolute humidity, 1 to 830 g/kg mixing ratio, or custom range corresponding to 4-20 mA. *Figure 8* below illustrates a typical configuration.

The same general specifications apply to the second current loop. However, the range for the second current loop is always 5 to 185°F (-15 to +85°C), corresponding to temperature, unless an optional display/user interface is used for a custom range.

**IMPORTANT:** Be sure that the two current loops are connected independently. DO NOT install a jumper at the MMR31 + and - terminals to power both current loops from a single power supply.

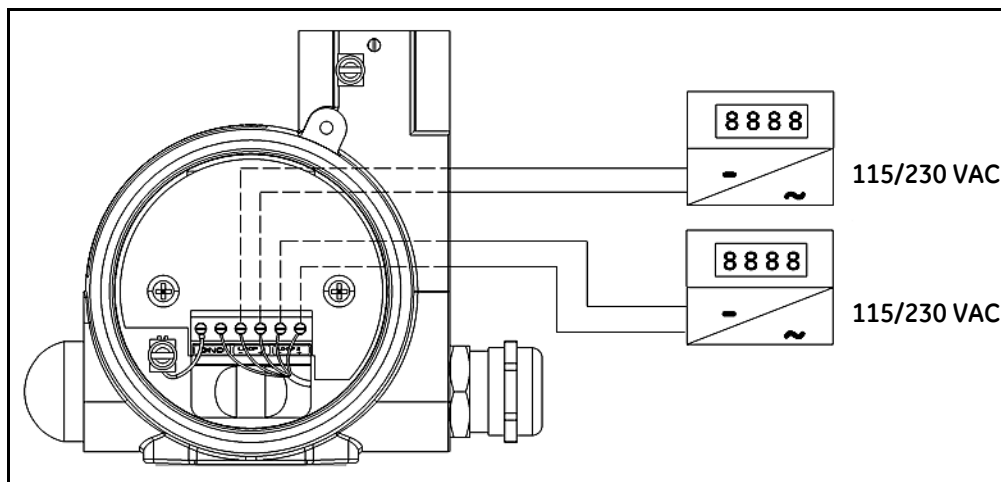

**Figure 8: System Configuration with Display and Power Supply**

### 2.3.2 Normal Environments

A standard two-wire, stranded cable can be used in a normal environment to interconnect the MMR31 with its loop power sources.

### 2.3.3 Environments with Severe Electrical Noise

When the MMR31 is installed in environments with severe electrical noise, wiring must be done with shielded and grounded cable, as shown in *Figure 9* below. Details of the MMR31 testing and certifications in such environments can be found in Chapter 5, "Specifications" on page 29, and the CE Declaration of Conformity at the end of this manual.

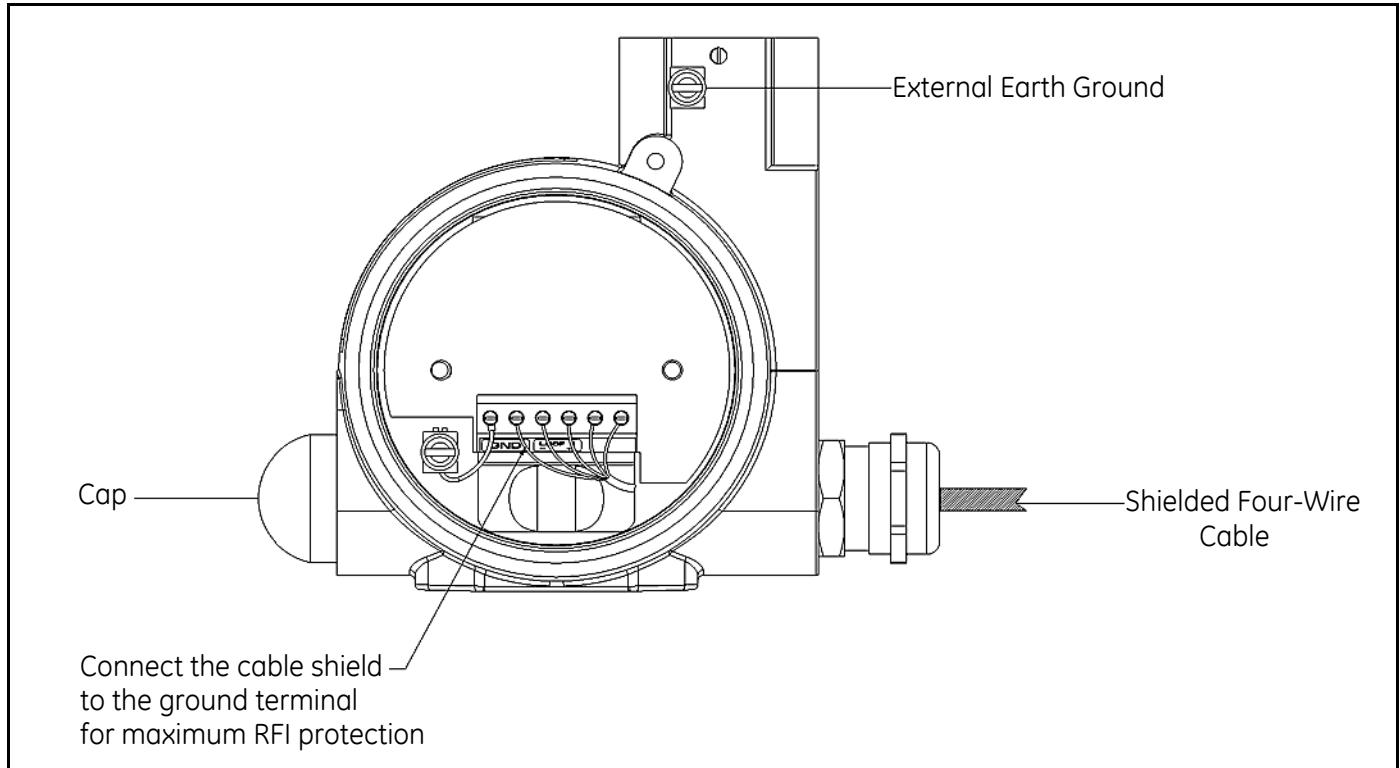

**Figure 9: Shielded Cable Wiring Diagram**

### 2.3.4 General Wiring Instructions

To wire the MMR31, refer to *Figure 10* below and complete the following steps:

1. Unscrew the cap on the terminal side of the unit.
2. Loosen the cable gland located on the side of the unit.
3. Feed the cable through the conduit opening.

**Note:** Use a standard signal cable size.

4. Retighten the metal cable gland to meet IP 67 and to relieve any stress on the wire.
5. Connect the wires to the MMR31 terminals as shown in *Figure 10* below.
6. Verify that a voltage between 12 and 28 VDC is present across the terminals marked + and –.

**Note:** This is the voltage that is actually measured across the MMR31 terminals. It is not necessarily exactly the same as the power supply voltage, due to voltage loss in the wires, displays, indicators, etc.

7. To meet EMI/RFI immunity requirements, a four-wire shielded cable with a common foil shield layer is used to power the MMR31. To clamp the shield foil in the metal cable gland, remove 3 in. (75 mm) of the insulation and fold back the foil. The ground wire must be connected to the internal grounding screw.

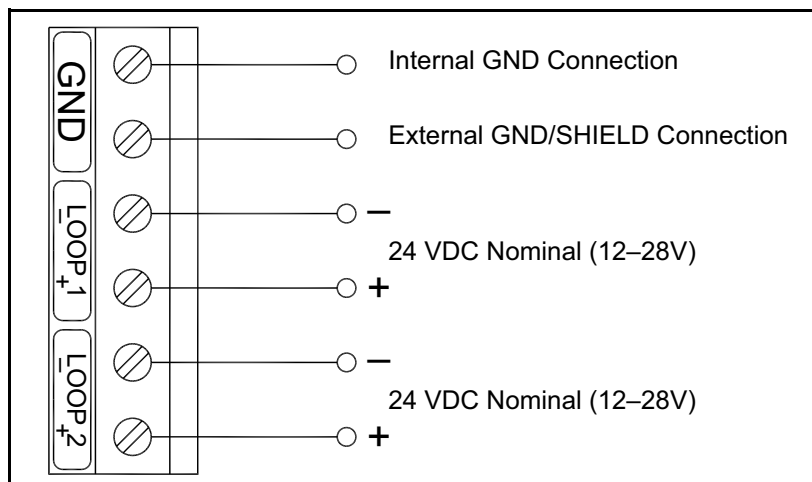
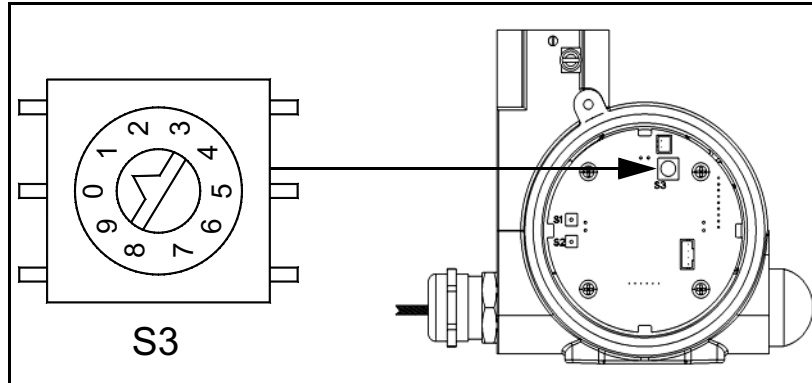

**Figure 10: Electrical Connections - Two Current Loops**

## 2.4 Selecting the Units of Measure

Unless otherwise specified, the MMR31 is shipped with a standard range of 0-100% relative humidity. To select other units of measure, complete the following steps:

1. Remove the cover opposite to the wiring compartment to access *Switch S3* (see *Figure 11* below).



**Figure 11: Switch S3 Location**

2. Using a 2-mm screwdriver, turn *Switch S3* to the position corresponding to your desired units of measure. The available options are listed in *Table 1* below:

**Table 1:**

Switch S3 Position	Mode	Range
0	% RH	0 to 100%
1	Dew point	5 to 185°F (-15 to +85°C)
2	Mixing Ratio	1 to 830 g/kg
3	Absolute Humidity	1 to 350 g/m <sup>3</sup>
8	Dew point	Custom
9	% RH Calibration with Salt Bottles (75.4 and 11.3%)	0 to 100%

For example, if *Switch S3* is set to *position 1* to select *dew point mode*, the current output represents a 5 to 185°F (-15 to +85°C) dew point temperature range. Any attached indicators need to be rescaled from their original RH (0-100%) range to the new dew point range.

## Chapter 3. Calibration and Troubleshooting

### 3.1 Calibration Using Two Saturated Salt Solutions



**CAUTION!** Be certain that the system is depressurized. The MMR31 must be removed from the process prior to calibration.

Utilizing saturated salt solutions is one of many methods available to calibrate a relative humidity sensor. Depending on the salt used (lithium chloride and sodium chloride are recommended), a defined relative humidity will occur above the solution at a given temperature. The accuracy of this method is dependent on the stability of the temperature during the calibration. It is important that the temperature of the salt solution and the temperature of the enclosed atmosphere above the solution are the same.

**Note:** *To achieve optimum results, it is recommended that calibration be performed at 77.5°F (25.3°C) because the temperature compensation correction is zero at this temperature. Deviating from this value by ±9°F (±5°C) will introduce an error of approximately 1%.*

To complete the following procedure, you will need:

- Two salt calibration bottles (11.3% and 75.4%) of the type available from Panametrics for RH field calibration
- Screwdriver, 2-mm wide
- An ammeter or current display with a range of 0-100 mA

## 3.2 Calibration Steps

**Note:** The following steps describe the use of an ammeter for calibration. If the current loop already contains a current display to indicate the moisture values, an additional ammeter is unnecessary.

1. Remove both covers from the MMR31 enclosure.
2. Disconnect the negative (–) lead of moisture loop 1.
3. Connect the ammeter into the loop as shown in Figure 12 below.
4. Choose the 20 mA range on the ammeter.

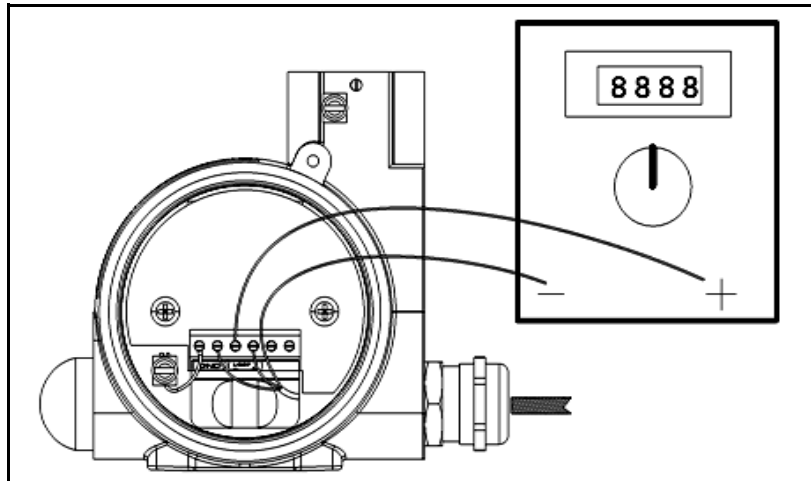

Figure 12: Ammeter Connections

Two buttons (**S1** and **S2**) and one rotary switch (**S3**) are located on the circuit board. Button **S1** is used to calibrate the 11.3% RH value with a lithium chloride salt solution, while button **S2** is used to calibrate the 75.4% RH value with a sodium chloride salt solution. Switch **S3** is set to position 9 for calibration mode (see Figure 13 below).

**Note:** If the unit is equipped with a display, the buttons on the display are used instead (see Chapter 4, "Optional Display/User Interface" on page 19 for detailed instructions).

5. Use a 2-mm screwdriver to turn Switch 3 to position 9.

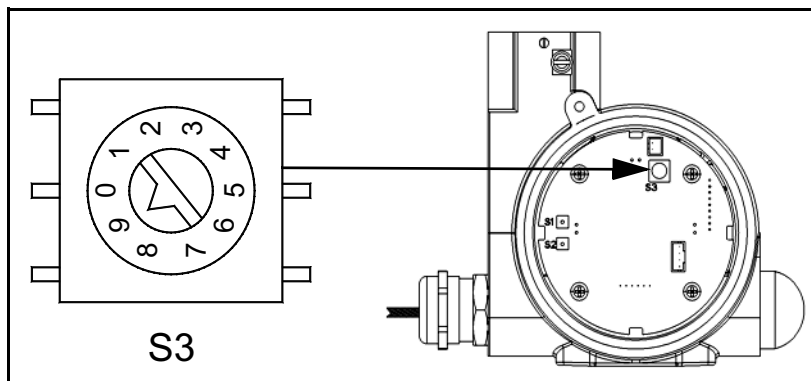

Figure 13: Setting Switch S3

### 3.2.1 Calibrating the Low RH Reading

**Note:** For the low RH reading, a saturated salt solution of lithium chloride is used to provide an 11.3% relative humidity reference.

1. Insert the probe into the calibration bottle, almost to the bottom.
2. Observe the ammeter. The reading will change toward 5.8 mA (or 11.3% on a display) after insertion of the probe.



**Note:** For successful calibration, it is important that the temperature in the salt solution and in the enclosed atmosphere above the solution reach equilibrium at the same value. After waiting for approximately two hours, the ammeter reading should stabilize.

3. If the meter reading is stable at 5.80 mA (or 11.3% on a display), press **S1** for at least one second. This assigns the 11.3% RH value. If only the low RH calibration will be performed, return *Switch S3* to position 0 (see *Figure 13* on page 16). Otherwise, continue to the next section to calibrate the high RH reading.

### 3.2.2 Calibrating the High RH Reading

**Note:** For the high RH reading, a saturated salt solution of sodium chloride is used to provide an 75.4% relative humidity reference.

1. Insert the probe into the calibration bottle, almost to the bottom.
2. Observe the ammeter. The reading will change toward 16 mA (or 75.4% on a display) after insertion of the probe.

**Note:** For successful calibration, it is important that the temperature in the salt solution and in the enclosed atmosphere above the solution reach equilibrium at the same value. After waiting for approximately two hours, the ammeter reading should stabilize.

3. If the meter reading is stable at 16 mA (or 75.4% on a display), press **S2** for at least one second. This assigns the 75.4% RH value. Return *Switch S3* to position 0 (see *Figure 13* on page 16).
4. After successful calibration, remove the ammeter, reconnect the negative (-) lead and reinstall the cover.

**Note:** During calibration, if the wrong key is pressed, the value will not be accepted due to a plausibility check

## 3.3 Troubleshooting

### 3.3.1 Loop Current is Out of Range

#### 3.3.1.1 Unit of Measure is RH

**Note:** 0% and 100% relative humidity are absolute limits. However, a defective sensor or a malfunction of the sensor electronics could generate sensor signal values which are outside the 0-100% range. If the sensor signal value is above 100% or below 0%, the current will go to the fault current specified on the order or in the matrix field VH 07.

**Solution:** Expose the sensor to ambient air which normally has a relative humidity between 10% and 90%. If the current returns the 4–20 mA range, check the sensor calibration (see “Calibration Steps” on page 16). However, if the current remains in error mode contact Panametrics for assistance.

#### 3.3.1.2 Unit of Measure is Dew Point

**Solution 1:** The process dew point is out of range. If the dew point is above 185°F (85°C), the current will go to the fault current specified on the order or in the matrix field VH 07. Apply dry air for a few minutes. If the current remains in error mode contact Panametrics for assistance.

**Solution 2:** If the dew point is below 5°F (–15°C), the current will go to the fault current specified on the order or in the matrix field VH 07. Move the sensor into a wetter environment for a few minutes. If the dew point doesn't increase, the cause may be a defective sensor assembly or an electronics malfunction. Contact Panametrics for assistance.

**Note:** The same approach is valid for the other available units of measure and for the second loop (temperature).

### 3.3.2 No Loop Current

**Solution:** Check the voltage and polarity across the positive (+) and negative (–) terminals of the MMR31 with a DC voltmeter. If the voltage is within the 12–28 VDC range, contact Panametrics for assistance.

### 3.3.3 Slow Response Time

**Solution:** Remove the protective filter cap by turning it counter-clockwise, and clean it with air flow or a solvent. If the sensor filter is contaminated, clean it with hot water using a brush.

### 3.3.4 Frozen Output Current

**Solution:** Check Switch S3, which should be in position 0, 1, 2, 3, 8 or 9.

## Chapter 4. Optional Display/User Interface

### 4.1 Accessing the Programming Buttons

If your MMR31 is equipped with an optional display/user interface, follow the procedure below to access the programming buttons.

#### 4.1.1 Removing the Display

To remove the display/user interface, refer to *Figure 14* below and complete the following steps:

1. Unscrew and remove the protective cover from the top of the MMR31, exposing the display module. The four buttons **V**, **H**, **+** and **-** are now accessible.
2. The display unit snaps onto the printed circuit board and rests on four posts. When removing the display, push one post to the outside, using a small screwdriver, and pull the display out.
3. Then, unplug the display cable.

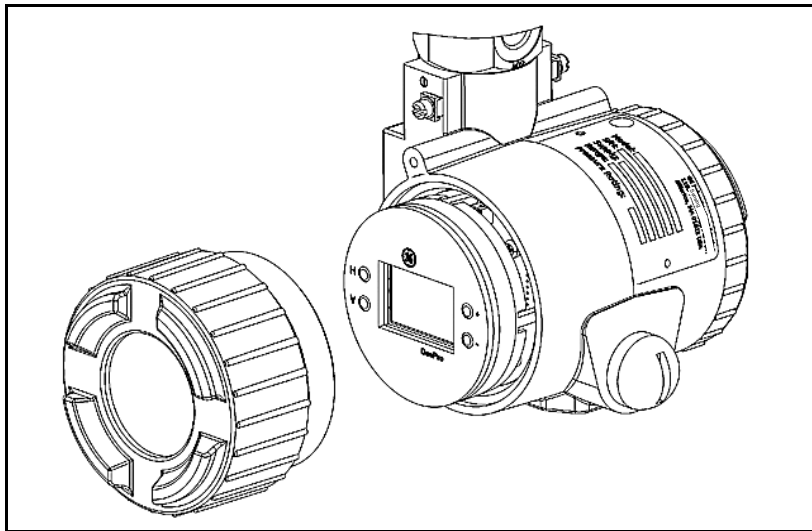

Figure 14: MMR31 with Display

## 4.2 Programming the Matrix

In the MMR31 with the display option, a matrix-style input is used for programming the units of measure, measuring range, error status of output, and output adjustment.

**Note:** For users of other Panametrics equipment, this matrix format may be familiar. However, this section describes the features and usage of the various matrix locations only as they apply to the MMR31.

The MMR31 display (see Figure 15 below) continuously shows the current matrix location using the vertical (**V**) and horizontal (**H**) coordinates to designate the row and column, respectively. The bar graph represents the output current in an analog fashion.

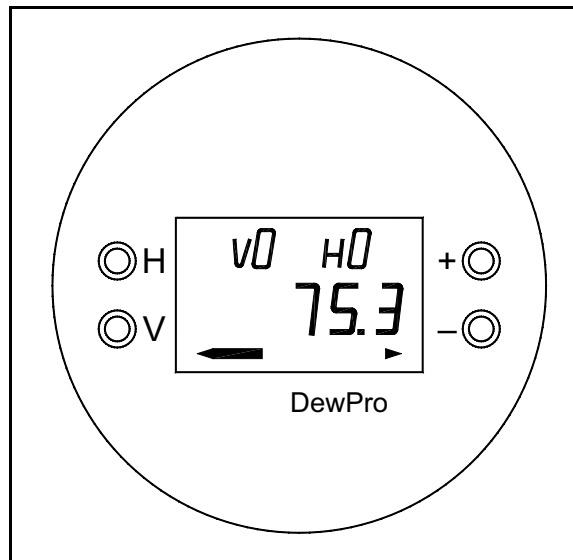

Figure 15: MMR31 Display

The **V** and **H** buttons are used to move to another row or column in the matrix (see Table 3 on page 21). For example, to select location **VH 45** from a starting location of **VH 00**, press **V** four times and then press **H** five times to arrive at **VH 45** (i.e., row 4 and column 5).

At any matrix location where the matrix value may be changed by the user, the digit to be changed is flashing, and the desired value is programmed using the **+** and **-** buttons. For example, at matrix location **VH 01**, the desired moisture units are selected by choosing from the matrix values listed in Table 2 below.

Table 2:

Matrix	Moisture Unit
0	% RH
1	Td °C
2	Td °F
3	g/m <sup>3</sup>
4	g/kg

Table 3:

MMR31	Row	H0	H1	H2	H3	H4	H5	H6	H7	H8	H9
Moisture Unit	V0	Display Moisture Value	Select Moisture Unit (see Table 2)						Loop 1 at Fault 0 = -10% 1 = 110% 2 = Hold	Loop 1 Raw Reading	
Loop Range	V1	%RH 4 mA	%RH 20 mA	Dewpoint °C 4 mA	Dewpoint °C 20 mA	Dewpoint °F 4 mA	Dewpoint °F 20 mA	g/m <sup>3</sup> 4 mA	g/m <sup>3</sup> 20 mA	g/kg 4 mA	g/kg 20 mA
	V2										
Constant; Loop Hardware Calibration	V3	Pressure Constant in mmHg								Loop 1 D/A Calibration Low	Loop 1 D/A Calibration High
Temp. Unit; Loop 1 Hardware Calibration	V4	Display Temp. Value	Select Unit of Temp. 0 = °C; 1 = °F				Temp. 4 mA	Temp. 20 mA	Loop 2 at Fault 0 = -10% 1 = 110% 2 = Hold	Loop 2 Raw Reading	
	V5										
RH Calibration	V6								Enable Calibration; enter digit other than 0	Enter Low RH (%)	Enter High RH (%)
Loop 2 Hardware Calibration	V7									Loop 2 D/A Calibration Low	Loop 2 D/A Calibration High
Access Key	V8										Input Locking 50 = Unlock System Reset 50 = Reset
Misc. Setup	V9	Display Present Error	Previous Error	Unit ID	Software Version		Reset to Defaults 50 = Reset				

## 4.3 Matrix Buttons – Special Functions

### 4.3.1 Reset to “Normal” Display

Pressing the **V** and **H** buttons simultaneously returns the user to **VH 00** (normal display).

### 4.3.2 Display Only

Eight (8) matrix locations are for display only and may not be changed by the user (see *Table 3 on page 21*). The “display only” fields are as follows:

**Table 4:**

Location	Display Description
VH 00	Normal display (in dewpoint, % RH, mixing ratio or absolute humidity as selected in VH 01)
VH 08	Indicates digitized moisture signal
VH 40	Displays temperature
VH 48	Indicates digitized temperature signal
VH 90	During a system alarm, displays the error code for the fault encountered
VH 91	During normal operation, displays the previous error code for reference
VH 92	Displays the factory issued identification number
VH 93	Displays the factory-issued reference number designating the device type and software version

### 4.3.3 Default Values

A default value is assigned to each programmable matrix field. These values are loaded after a reset to factory programmed data has been executed (see **VH 95**).

## 4.4 Matrix Functions

This section describes the functions available to the user through the matrix, grouped by common function areas (see *Table 3 on page 21*). Each function is accessed by moving to its specified location within the matrix.

### 4.4.1 System Administration Functions

**Table 5:**

Function	Location	Description
Locking/ Unlocking the Matrix	VH 89	This location allows the user to lock and unlock the matrix input functions. When the matrix is locked, the <b>V</b> and <b>H</b> keys are still functional but the <b>+</b> and <b>-</b> keys are disabled. This prevents unauthorized modification of any of the user input functions, such as output ranging or units selection. Entering the value <b>50</b> in this location unlocks the matrix. Any other value locks the matrix. (Default: 0)
System Reset	VH 99	This location allows the user to reset the system electronics in a manner similar to removing and re-applying power. No system parameter settings are modified. Entering the value <b>50</b> in this location initiates the reset, and after approximately five (5) seconds the reset is executed. After the reset, normal operation is resumed at location <b>VH 00</b> .
Transmitter Identification	VH 92	This location displays the identification number of the transmitter. The display should read <b>200</b> .
Software Version	VH93	This location displays the version number of the instrument software.
Two-Point Calibration Using Any Low and High RH Value	VH67	In this location, the calibration using <b>VH 68</b> and <b>VH 69</b> is enabled by entering any digit other than <b>0</b> . Follow the steps described in “ <i>Calibration Steps</i> ” on page 16. Enter <b>11.3</b> in <b>VH 68</b> and <b>75.4</b> in <b>VH 69</b> .  If a different moisture source is being used (e.g., a variable moisture generator or other saturated salt solutions), any low value can be entered in <b>VH 68</b> and any high value in <b>VH 69</b> . Be sure the high and low values differ by at least 20%.  The hardware buttons on the printed circuit board are still active, performing an <b>11.3</b> and <b>75.4</b> calibration. As described in “ <i>Calibration Steps</i> ” on page 16, location <b>VH 68</b> would reset to <b>11.3</b> and location <b>VH 69</b> to <b>75.4</b> .
Low RH Point Calibration	VH68	Enter the low RH value in % when the reading is stable. <b>VH 67</b> has to have a value other than <b>0</b> . Be sure the high and low values differ by at least 20%.
High RH Point Calibration	VH 69	Enter the high RH value in % when reading is stable. <b>VH 67</b> has to have a value other than <b>0</b> . Be sure the high and low values differ by at least 20%.

## 4.4.2 Moisture Measurement Functions

Table 6:

Function	Location	Description
Display Current Process Value	VH 00	This location displays the current process humidity value measured by the instrument. The units of measure for the displayed value (i.e., % RH, dew point or units selected under <b>VH 01</b> ) is selected in position <b>VH 01</b> . The bar graph beneath the numeric display represents the position of the current value within the range programmed for the selected units of measure.
Select Units of Measure for Display	VH 01	This location selects the units of measure to be used for the humidity value display. The available options are: 0 = % relative humidity (Default) 1 = °C dew point 2 = °F dew point 3 = grams/m <sup>3</sup> 4 = grams/kg dry air.
Loop #1 at Fault	VH 07	This location specifies the state of current output #1, corresponding to the detection of a fault with either the humidity sensor or the measurement circuitry. The available options are: 0 = -10% (3.6 mA) 1 = 110% (22 mA) (Default) 2 = Hold at previous level
Display the Moisture Frequency	VH 08	When this location is selected, the A/D counts from the moisture measurement circuit are displayed.

## 4.4.3 4-20 mA Output Range Functions

Table 7:

Function	Location	Description
Range of Humidity Values	VH 10	% RH 4mA (Default: 0)
	VH 11	% RH 20mA (Default: 100)
	VH 12	°C dew point 4mA (Default: -15)
	VH 13	°C dew point 20mA (Default: +85)
	VH 14	°F dew point 4mA (Default: 5)
	VH 15	°F dew point 20mA (Default: 185)
	VH 16	grams/m <sup>3</sup> 4mA (Default: 1)
	VH 17	grams/m <sup>3</sup> 20mA (Default: 350)
	VH 18	grams/kg dry air 4mA (Default: 1)
	VH 19	grams/kg dry air 20mA (Default: 830)
Pressure Constant Adjustment	VH 30	This location allows the user to enter a value for the process pressure. The value is entered in mmHg. This value is used only for the calculation of the unit grams/kg dry air. (Default: 760)
Calibrating the Current Output	VH 38 VH 39	These locations are used to calibrate the 4 mA and 20 mA hardware settings of the humidity output current loop. This output comes calibrated from the factory and should not normally need adjustment. To check the setting, connect an ammeter in series with the negative (-) power terminal for loop #1 (see "Wiring Configurations with One Current Loop" on page 8). Move to matrix location <b>VH 38</b> . The output will automatically change to the 4 mA setting. Adjust as necessary using the + and - keys. Move to location <b>VH 39</b> . The output will automatically change to the 20 mA setting. Adjust as necessary. Move to any other matrix location to return the output to normal operation.  If the matrix input is locked ( <b>VH 89</b> ), the calibration values are displayed, but the current output is unaffected.



#### 4.4.4 Temperature Measurement Functions

Table 8:

Function	Location	Description
Displaying the Measured Temperature	VH 40	Selecting this location displays the present process temperature. The unit of measure (°F/°C) is the unit selected in location <b>VH41</b> (see below).
Selecting the Temperature Unit	VH 41	This allows the user to select either °F or °C as the temperature measurement unit to be displayed in location <b>VH 40</b> . Setting this location to <b>0</b> selects °C, and setting to <b>1</b> selects °F. (Default: 0)
Setting the Temperature Output Range	VH 45 VH 46	These locations specify the range of temperatures corresponding to the 4–20 mA range of current output #2. The range of values for both locations is from <b>-15</b> and <b>+85</b> . The output range is always specified in °C, regardless of the display units selected.
Loop #2 at Fault	VH 47	This location specifies the condition for current output #2 when a fault is detected in the temperature measurement circuitry. The available options are: 0 = -10% (3.6 mA) 1 = 110% (22 mA) (Default) 2 = Hold at previous level
Calibrating the Current Output	VH 78 VH 79	These locations are used to calibrate the 4 mA and 20 mA hardware settings of the temperature output current loop. This output comes calibrated from the factory and should not normally need adjustment. To check the setting, connect an ammeter in series with the negative (-) power terminal for loop #2. Move to matrix location <b>VH 78</b> . The output will automatically change to the 4 mA setting. Adjust as necessary using the + and - keys. Move to location <b>VH 79</b> . The output will automatically change to the 20 mA setting. Again, adjust as necessary. Move to any other matrix location to return the output to normal operation.  If the matrix input is locked ( <b>VH 89</b> ), the calibration values are displayed, but the current output is unaffected.

### 4.4.5 Error Codes

During normal MMR31 operation, it is possible for the temperature channel to be in error, while the RH channel still reads correctly. It is also possible for the RH channel to be in error, while the temperature channel still reads correctly. If a moisture unit that depends on both the RH and temperature values (e.g., dewpoint) is selected, the error conditions for both RH < 0% and RH > 100% will be set. MMR31 errors are indicated in the matrix (see *Table 3 on page 21*), as shown in *Table 9* below.

**Table 9:**

Function	Location	Description
Display the Present Error Code	VH 90	This location displays a number associated with an error code. If no error condition exists, the location displays <b>0</b> . Use the instructions in this section to properly interpret the error code.

The procedure for interpreting the **VH 90** error codes involves the conversion of numbers from decimal format into binary format. To perform these conversions, refer to *Table 10* below.

**Table 10:**

Decimal Value	Binary Equivalent
0	0000
1	0001
2	0010
3	0011
4	0100
5	0101
6	0110
7	0111
8	1000
9	1001
10	1010
11	1011
12	1100
13	1101
14	1110
15	1111

#### 4.4.5 Error Codes (cont.)

When a value other than **0** is displayed in matrix location **VH 90**, complete the following steps to determine the cause of the error (a value of **39** is used as an example in the steps below):

1. Divide the error code displayed in matrix location **VH 90** by 16.  
[Example:  $39/16 = 2.4375$ ]
2. Determine the *temperature channel* error code by converting the integer portion of the result in step 1 to binary format (see *Table 10 on page 26*).  
[Example: integer portion of  $2.4375 = 2 = 0010$  binary]
3. Determine the *moisture channel* error code by multiplying the decimal portion of the result in step 1 by 16 and then converting the result to binary format (see *Table 11 on page 27*).  
[Example:  $16 \times \text{decimal portion of } 2.4375 = 16 \times 0.4375 = 7 = 0111$  binary]
4. Each "1" in the binary values calculated in steps 2 and 3 above corresponds to a particular MMR31 error. Identify these errors by referring to *Table 11* below.  
[Example: The "1" in the third position of the *temperature channel* error code (see step 2 above) means that the temperature reading is **> 85°C**. The "1" in the second, third and fourth positions of the *moisture channel* error code (see step 3 above) means that Output 1 is **< 4 mA** and that the moisture unit selected depends on the temperature.

**Table 11:**

Temperature Channel 4-Digit Code				Moisture Channel 4-Digit Code			
X	X	X	X	X	X	X*	X*
CH2 Output > 20 mA	CH2 Output < 4 mA	Temp. > +85°C	Temp. < -15°C	CH1 Output > 20 mA	CH1 Output < 4 mA	RH > 100%	RH < 0%
* If both of these positions are set to "1", the selected moisture unit depends on the temperature.							

To further illustrate the process, let's try one more example. If the **VH 90** matrix location displays an error code of **1**:

Step 1:  $1/16 = 0.0625$

Step 2: *temperature channel* error code = integer portion of  $0.0625 = 0 = 0000$  binary

Step 3: *moisture channel* error code =  $16 \times \text{decimal portion of } 0.0625 = 16 \times 0.0625 = 1 = 0001$  binary

Step 4: There are no temperature errors. The moisture error indicates that **RH < 0%**

[no content intended for this page]

## Chapter 5. Specifications

### 5.1 Technical Specifications

**Sensing Element:**

Silicon-based polymer, capacitance principle, IC electronics

**RH Range:**

0 to 100%

**RH Accuracy:**

±2% in the range of 0% to 90% at 25°C

±3% in the range of 90% to 100% at 25°C

**Dew Point Range:**

5 to 185°F (-15 to +85°C)

**Dew Point Accuracy:**

±1.8°F (±1°C) above 32°F (0°C), T < 86°F (< 30°C) and RH > 30%

**Operating Temperature Range:**

5 to 185°F (-15 to +85°C); temperature signal available with second loop

**Operating Temperature of Electronics:**

-40 to +185°F (-40 to +85°C)

**Temperature Accuracy:**

±0.9°F (±0.5°C)

**Absolute Humidity Range:**

1 to 350 g/m<sup>3</sup>

**Mixing Ratio Range:**

1 to 830 g/kg

**Maximum Operating Pressure:**

250 psig (17 bar)

**Outputs:**

Loop current 4 to 20 mA, 16 µA resolution, optional output for temperature

## 5.1 Technical Specifications (cont.)

**Electronics:**

Microcontroller operation

**EM I/RFI Protection:**

See "EMI/RFI Protection" on page 31

**Moisture Units:**

% RH, dew point temperature in °F or °C, absolute humidity in g/m<sup>3</sup>, or mixing ratio in g/kg, hardware selectable

**Power Supply:**

24 VDC nominal, 12 to 28 VDC range

**Protection:**

Type 4X (IP67)

**Probe Tube:**

316 stainless steel, 1/2 in. (12.7 mm) diameter, insertion length 3.0 in. (75 mm) to 5.9 in. (150 mm), adjustable

**Typical Probe Mounting:**

1/2 in. (12.7 mm) tube x 1/2 in. (12.7 mm) NPT-M or

1/2 in. (12.7 mm) tube x G 1/2 compression fitting.

**Weight:**

3.3 lb (1.5 kg)

## 5.2 Optional Onboard Display with User Interface

The optional onboard display with user interface uses a matrix configurator for:

- Range changes
- Unit of measure selection
- Current loop adjustment
- Error diagnostics
- Current value selection for fault conditions

### 5.3 EMI/RFI Protection

IEC 61000-4, Performance Criterion A test results for the MMR31 were as follows:

- Conducted Emission Test as per CISPR 11 Class A, 2004
- Radiated Emission Test as per CISPR 11 Class A, 2004
- Radiated Susceptibility Test as per IEC 61000-4-3, 2002
- Electrostatic Discharge Test as per IEC 61000-4-2, 2001
- Electrical Fast Transient Test as per IEC 61000-4-4, 2004
- High Energy Surge Immunity Test as per IEC 61000-4-5, 2001
- Power Frequency Magnetic Field Test as per IEC 61000-4-8, 2001

### 5.4 EMC Compliance

The MMR31 meets the EMC requirements of IEC 61326 for equipment used in industrial locations

### 5.5 Available Accessories

The following optional accessories are available for the MMR31:

- Single power supply
- Panel mount display, power supply, no relays
- Panel mount display, power supply, two alarms
- Panel mount display, power supply, two alarms, 4-20 mA repeating output

**Note:** For other requirements, contact Panametrics for assistance.

[no content intended for this page]



	<b>A</b>	
Accessories, Available .....		31
Ammeter, Calibration .....		15
	<b>B</b>	
Binary Conversion Table .....		26
Bracket, Mounting with .....		7
Buttons		
Calibration .....		16
Matrix Programming .....		20
Programming, Accessing .....		19
Special Functions .....		22
	<b>C</b>	
Cable, Shielded .....		9
Calibration		
Ammeter .....		15
Buttons .....		16
High RH Reading .....		17
Low RH Reading .....		16
NIST Reference .....		3
Steps Required .....		16
Switch .....		16
Using Saturated Salt Solutions .....		15
Components, Transmitter .....		3
Compression Fitting, Mounting with .....		6
Conversion, Decimal to Binary Table .....		26
	<b>D</b>	
Date of Publication .....		i
Default Values, Matrix .....		22
Dimensions, Mounting .....		5
Display		
Matrix Locations .....		22
Removing .....		19
Display/User Interface		
Programming Buttons .....		20
Specifications .....		30
Document Number .....		i
	<b>E</b>	
Electrical Connections		
One Current Loop .....		10
Two Current Loops .....		13
Electrical Noise .....		9, 12
EMC Compliance .....		31
EMI/RFI Protection .....		31
Environmental Compliance .....		ii
Error Codes		
Examples .....		27
Interpreting .....		27
Matrix Location .....		26
Examples, Error Codes .....		27
	<b>F</b>	
Flange, Mounting with .....		6
Functions		
4–20 mA Output Range .....		24
Matrix .....		23
Moisture Measurement .....		24
System Administration .....		23
Temperature Measurement .....		25
	<b>G</b>	
Guidelines, Wiring .....		8, 11
	<b>I</b>	
Information Paragraphs .....		i
Installation		
Compression Fitting .....		6
Flange .....		6
In Pipe or Container .....		6
In Room .....		7
Mounting Dimensions .....		5
With Bracket .....		7
	<b>L</b>	
Label, Product .....		1
Loop		
Current Out of Range .....		18
First, Description .....		3
Frozen Output Current .....		18
No Current .....		18
One, Electrical Connections .....		10
Second, Description .....		3
Two, Electrical Connections .....		13
Wiring .....		8, 11
	<b>M</b>	
Matrix		
"Display Only" Locations .....		22
4–20 mA Output Range Functions .....		24
Default Values .....		22
Error Codes .....		26
Functions .....		23
Moisture Measurement Functions .....		24
Programming .....		20
System Administration Functions .....		23
Table of Options .....		21
Temperature Measurement Functions .....		25
Model Number .....		1, 2
Mounting Dimensions .....		5
	<b>N</b>	
NIST, Calibration Reference .....		3
Noise, Electrical .....		9, 12
Normal Environments, Wiring .....		9, 12
	<b>O</b>	
Operation, Theory .....		3
Options, Available .....		31
	<b>P</b>	
Pipe, Mounting in .....		6
Power Supply, Specifications .....		30
Product Label .....		1
Programming		
Buttons .....		20
Matrix .....		20
Programming Buttons, Accessing .....		19

---

<b>R</b>	
Removing the Display .....	19
Response Time, Slow .....	18
Return Policy .....	35
RH	
Calibrating High Reading .....	17
Calibrating Low Reading .....	16
Room, Mounting in .....	7
<b>S</b>	
Safety	
Auxiliary Equipment .....	i
General Issues .....	i
Personal Equipment .....	ii
Salt Solutions, Saturated for Calibration .....	15
Sensor, Description .....	3
Shielded Cable .....	9
Shipping Damage .....	1
Special Functions, Buttons .....	22
Specifications	
Display/User Interface .....	30
Power Supply .....	30
Technical .....	29
Switch, Calibration .....	16
<b>T</b>	
Technical Specifications .....	29
Terminals, Wiring .....	10, 13
Theory of Operation .....	3
Troubleshooting .....	18
Frozen Output Current .....	18
Loop Current Out of Range .....	18
No Loop Current .....	18
Slow Response Time .....	18
<b>U</b>	
Units of Measure	
Selecting .....	14
Unpacking .....	1
<b>V</b>	
Version Descriptions .....	2
<b>W</b>	
Warranty .....	35
WEEE Directive .....	ii
Weight, Transmitter .....	30
Wiring	
Electrical Noise .....	9, 12
General Guidelines .....	8, 11
General Instructions .....	10, 13
Normal Environments .....	9, 12
One Current Loop .....	8
Terminals .....	10, 13
Two Current Loops .....	11

---

## Warranty

Each instrument manufactured by Panametrics is warranted to be free from defects in material and workmanship. Liability under this warranty is limited to restoring the instrument to normal operation or replacing the instrument, at the sole discretion of Panametrics. Fuses and batteries are specifically excluded from any liability. This warranty is effective from the date of delivery to the original purchaser. If Panametrics determines that the equipment was defective, the warranty period is:

- One year from delivery for electronic or mechanical failures
- One year from delivery for sensor shelf life

If Panametrics determines that the equipment was damaged by misuse, improper installation, the use of unauthorized replacement parts, or operating conditions outside the guidelines specified by Panametrics, the repairs are not covered under this warranty.

---

**The warranties set forth herein are exclusive and are in lieu of all other warranties whether statutory, express or implied (including warranties or merchantability and fitness for a particular purpose, and warranties arising from course of dealing or usage or trade).**

---

## Return Policy

If a Panametrics instrument malfunctions within the warranty period, the following procedure must be completed:

1. Notify Panametrics, giving full details of the problem, and provide the model number and serial number of the instrument. If the nature of the problem indicates the need for factory service, Panametrics will issue a RETURN AUTHORIZATION NUMBER (RAN), and shipping instructions for the return of the instrument to a service center will be provided.
2. If Panametrics instructs you to send your instrument to a service center, it must be shipped prepaid to the authorized repair station indicated in the shipping instructions.
3. Upon receipt, Panametrics will evaluate the instrument to determine the cause of the malfunction.

Then, one of the following courses of action will then be taken:

- If the damage is covered under the terms of the warranty, the instrument will be repaired at no cost to the owner and returned.
- If Panametrics determines that the damage is not covered under the terms of the warranty, or if the warranty has expired, an estimate for the cost of the repairs at standard rates will be provided. Upon receipt of the owner's approval to proceed, the instrument will be repaired and returned.

[no content intended for this page]

## Contact Us!

<b>Break/fix technical support issues for a product you currently have</b>	<ul style="list-style-type: none"><li>• <b>Global Technical Support Team</b> Email: mstechsupport@bakerhughes.com Phone: 8000-833-9438, option 3.</li></ul>
<b>RMA Repair Requests, Calibration Requests, Document and Certificate requests for a product you currently have</b>	<ul style="list-style-type: none"><li>• <b>International – Baker Hughes Customer care</b> Email: gesensingorders@bakerhughes.com Phone: +36 27 565 314</li><li>• <b>North America only – Baker Hughes North America In House Services</b> Email: namservice@bakerhughes.com Phone: (281)542-3650</li></ul>
<b>Quotes, PO's and PO inquiries, Orders changes and Order inquiries, document requests for new product</b>	<ul style="list-style-type: none"><li>• <b>International – Baker Hughes Customer Care</b> Email: gesensingorders@bakerhughes.com Phone: +36 27 565 314</li><li>• <b>North America only – Baker Hughes North America Customer Care</b> Email: custcareboston@bakerhughes.com Phone: 800-833-9438, option 1.</li></ul>

Copyright 2020. Baker Hughes company.

This material contains one or more registered trademarks of Baker Hughes Company and its subsidiaries in one or more countries. All third-party product and company names are trademarks of their respective holders.

A40251532 Rev.C