

SIEMENS

SITRANS P

Pressure transmitter SITRANS LH300 Transmitter for Hydrostatic Level

Compact Operating Instructions



<u>Introduction</u>	1
<u>Safety instructions</u>	2
<u>Description</u>	3
<u>Installing/mounting</u>	4
<u>Connecting</u>	5
<u>Commissioning</u>	6
<u>Service and maintenance</u>	7
<u>Technical specifications</u>	8
<u>Dimension drawings</u>	9
<u>Product documentation and support</u>	A

7MF1575-.....-....

Legal information

Warning notice system

This manual contains notices you have to observe in order to ensure your personal safety, as well as to prevent damage to property. The notices referring to your personal safety are highlighted in the manual by a safety alert symbol, notices referring only to property damage have no safety alert symbol. These notices shown below are graded according to the degree of danger.

 DANGER
indicates that death or severe personal injury will result if proper precautions are not taken.
 WARNING
indicates that death or severe personal injury may result if proper precautions are not taken.
 CAUTION
indicates that minor personal injury can result if proper precautions are not taken.
NOTICE
indicates that property damage can result if proper precautions are not taken.

If more than one degree of danger is present, the warning notice representing the highest degree of danger will be used. A notice warning of injury to persons with a safety alert symbol may also include a warning relating to property damage.

Qualified Personnel

The product/system described in this documentation may be operated only by **personnel qualified** for the specific task in accordance with the relevant documentation, in particular its warning notices and safety instructions. Qualified personnel are those who, based on their training and experience, are capable of identifying risks and avoiding potential hazards when working with these products/systems.

Proper use of Siemens products

Note the following:

 WARNING
Siemens products may only be used for the applications described in the catalog and in the relevant technical documentation. If products and components from other manufacturers are used, these must be recommended or approved by Siemens. Proper transport, storage, installation, assembly, commissioning, operation and maintenance are required to ensure that the products operate safely and without any problems. The permissible ambient conditions must be complied with. The information in the relevant documentation must be observed.

Trademarks

All names identified by ® are registered trademarks of Siemens AG. The remaining trademarks in this publication may be trademarks whose use by third parties for their own purposes could violate the rights of the owner.

Disclaimer of Liability

We have reviewed the contents of this publication to ensure consistency with the hardware and software described. Since variance cannot be precluded entirely, we cannot guarantee full consistency. However, the information in this publication is reviewed regularly and any necessary corrections are included in subsequent editions.

Table of contents

1	Introduction	5
1.1	Purpose of this documentation	5
1.2	Checking the consignment.....	5
1.3	Transportation and storage	5
1.4	Notes on warranty	6
2	Safety instructions	7
2.1	Prerequisites for safe use.....	7
2.1.1	Laws and directives	7
2.1.2	Conformity with European directives	7
2.1.3	Conformity with UK directives	8
2.2	Improper device modifications.....	8
2.3	Requirements for special applications.....	8
2.4	Use in hazardous areas.....	9
3	Description	11
3.1	Application range	11
3.2	Structure	11
3.3	Design of the nameplate	12
3.4	Mode of operation	12
4	Installing/mounting	15
4.1	Basic safety instructions	15
4.1.1	Proper mounting.....	16
4.1.2	Use in maritime deployment	16
4.2	Installation	17
4.3	Setting up the measuring points.....	18
4.4	Establishing the measuring range	18
5	Connecting	19
5.1	Basic safety instructions	19
5.2	Connecting the device	21
6	Commissioning	23
6.1	Basic safety instructions	23
6.2	Calibrating.....	23
7	Service and maintenance	25
7.1	Basic safety instructions	25

7.2	Calibrating.....	25
7.3	Clean diaphragm	25
7.4	Maintenance and repair work.....	26
7.5	Return procedure	26
7.6	Disposal.....	27
8	Technical specifications	29
8.1	Certificates and approvals.....	32
9	Dimension drawings	33
A	Product documentation and support	35
A.1	Product documentation	35
A.2	Technical support.....	36
	Index	37

Introduction

1.1 Purpose of this documentation

These instructions contain all information required to commission and use the device. Read the instructions carefully prior to installation and commissioning. In order to use the device correctly, first review its principle of operation.

The instructions are aimed at persons mechanically installing the device, connecting it electronically, configuring the parameters and commissioning it, as well as service and maintenance engineers.

1.2 Checking the consignment

1. Check the packaging and the delivered items for visible damages.
2. Report any claims for damages immediately to the shipping company.
3. Retain damaged parts for clarification.
4. Check the scope of delivery by comparing your order to the shipping documents for correctness and completeness.



WARNING

Using a damaged or incomplete device

Risk of explosion in hazardous areas.

- Do not use damaged or incomplete devices.

1.3 Transportation and storage

To guarantee sufficient protection during transport and storage, observe the following:

- Keep the original packaging for subsequent transportation.
- Devices/replacement parts should be returned in their original packaging.
- If the original packaging is no longer available, ensure that all shipments are properly packaged to provide sufficient protection during transport. Siemens cannot assume liability for any costs associated with transportation damages.

NOTICE

Insufficient protection during storage

The packaging only provides limited protection against moisture and infiltration.

- Provide additional packaging as necessary.

Special conditions for storage and transportation of the device are listed in Technical specifications (Page 29).

1.4 Notes on warranty

The contents of this manual shall not become part of or modify any prior or existing agreement, commitment or legal relationship. The sales contract contains all obligations on the part of Siemens as well as the complete and solely applicable warranty conditions. Any statements regarding device versions described in the manual do not create new warranties or modify the existing warranty.

The content reflects the technical status at the time of publishing. Siemens reserves the right to make technical changes in the course of further development.

Safety instructions

2.1 Prerequisites for safe use

This device left the factory in good working condition. In order to maintain this status and to ensure safe operation of the device, observe these instructions and all the specifications relevant to safety.

Observe the information and symbols on the device. Do not remove any information or symbols from the device. Always keep the information and symbols in a completely legible state.

Symbol	Explanation
	Consult operating instructions

2.1.1 Laws and directives

Observe the safety rules, provisions and laws applicable in your country during connection, assembly and operation. These include, for example:

- National Electrical Code (NEC - NFPA 70) (USA)
- Canadian Electrical Code (CEC) (Canada)

Further provisions for hazardous area applications are for example:

- IEC 60079-14 (international)
- EN 60079-14 (EU)

2.1.2 Conformity with European directives

The CE mark on the device is a sign of conformity with the following European directives:

Electromagnetic compatibility EMC 2014/30/EU	Directive of the European Parliament and of the Council on the harmonisation of the laws of the Member States relating to electromagnetic compatibility.
Atmosphère explosible ATEX 2014/34/EU	Directive of the European Parliament and of the Council on the harmonisation of the laws of the Member States relating to equipment and protective systems intended for use in potentially explosive atmospheres.
2011/65/EU RoHS	Directive of the European Parliament and of the Council on the restriction of the use of certain hazardous substances in electrical and electronic equipment

2.3 Requirements for special applications

The standards applied can be found in the EC declaration of conformity for the device.

2.1.3 Conformity with UK directives

The UKCA marking on the device shows conformity with the following UK regulations:

Electromagnetic Compatibility SI 2016/1091	Electromagnetic Compatibility Directive 2016
Explosive Atmospheres SI 2016/1107	Directive for Equipment and Protective Systems Intended for use in Potentially Explosive Atmospheres 2016
Directive on the Restriction of the Use of Certain Hazardous Substances SI 2012/3032	Directive on the Restriction of the Use of Certain Hazardous Substances in Electrical and Electronic Equipment 2012

The applicable regulations can be found in the UKCA declaration of conformity of the specific device.

2.2 Improper device modifications

 WARNING
Improper device modifications Risk to personnel, system and environment can result from modifications to the device, particularly in hazardous areas. <ul style="list-style-type: none">• Only carry out modifications that are described in the instructions for the device. Failure to observe this requirement cancels the manufacturer's warranty and the product approvals.

2.3 Requirements for special applications

Due to the large number of possible applications, each detail of the described device versions for each possible scenario during commissioning, operation, maintenance or operation in systems cannot be considered in the instructions. If you need additional information not covered by these instructions, contact your local Siemens office or company representative.

Note

Operation under special ambient conditions

We highly recommend that you contact your Siemens representative or our application department before you operate the device under special ambient conditions as can be encountered in nuclear power plants or when the device is used for research and development purposes.

2.4 Use in hazardous areas

Qualified personnel for hazardous area applications

Persons who install, connect, commission, operate, and service the device in a hazardous area must have the following specific qualifications:

- They are authorized, trained or instructed in operating and maintaining devices and systems according to the safety regulations for electrical circuits, high pressures, aggressive, and hazardous media.
- They are authorized, trained, or instructed in carrying out work on electrical circuits for hazardous systems.
- They are trained or instructed in maintenance and use of appropriate safety equipment according to the pertinent safety regulations.

 WARNING
Use in hazardous area Risk of explosion. <ul style="list-style-type: none">• Only use equipment that is approved for use in the intended hazardous area and labelled accordingly.• Don't use devices that have been operated outside the conditions specified for hazardous areas. If you have used the device outside the conditions for hazardous areas permanently make all Ex markings unrecognizable on the nameplate.

See also

Technical specifications (Page 29)

 WARNING
Loss of safety of device with type of protection "Intrinsic safety Ex i" If the device has already been operated in non-intrinsically safe circuits or the electrical specifications have not been observed, the safety of the device is no longer ensured for use in hazardous areas. There is a risk of explosion. <ul style="list-style-type: none">• Connect the device with type of protection "Intrinsic safety" solely to an intrinsically safe circuit.• Observe the specifications for the electrical data on the certificate and/or in Technical specifications (Page 29).

2.4 Use in hazardous areas

Description

3.1 Application range

The LH300 pressure transmitter is a submersible sensor for hydrostatic level measurement. The pressure transmitter measures the liquid levels in tanks, containers, channels and dams.

The pressure transmitter is available for various measuring ranges and optionally with explosion protection. A cable box and an anchor clamp are available as accessories to make installation easier.

The pressure transmitter is used, for example, in the following industrial areas:

- Water supply
- For use in pressureless/open tanks and wells
- Shipbuilding and marine equipment

3.2 Structure

The pressure transmitter has a built-in ceramic sensor which is equipped with a Wheatstone resistance bridge.

The pressure transmitter is equipped with electronics that is installed, together with the sensor, in a stainless steel enclosure. There is also a vent pipe in the connecting cable.

The measuring diaphragm is effectively protected against external influences by a protective cover.

The sensor, the electronics and the connecting cable are housed in an enclosure with small dimensions.

The pressure transmitter is suitable for a wide temperature range.

3.3 Design of the nameplate

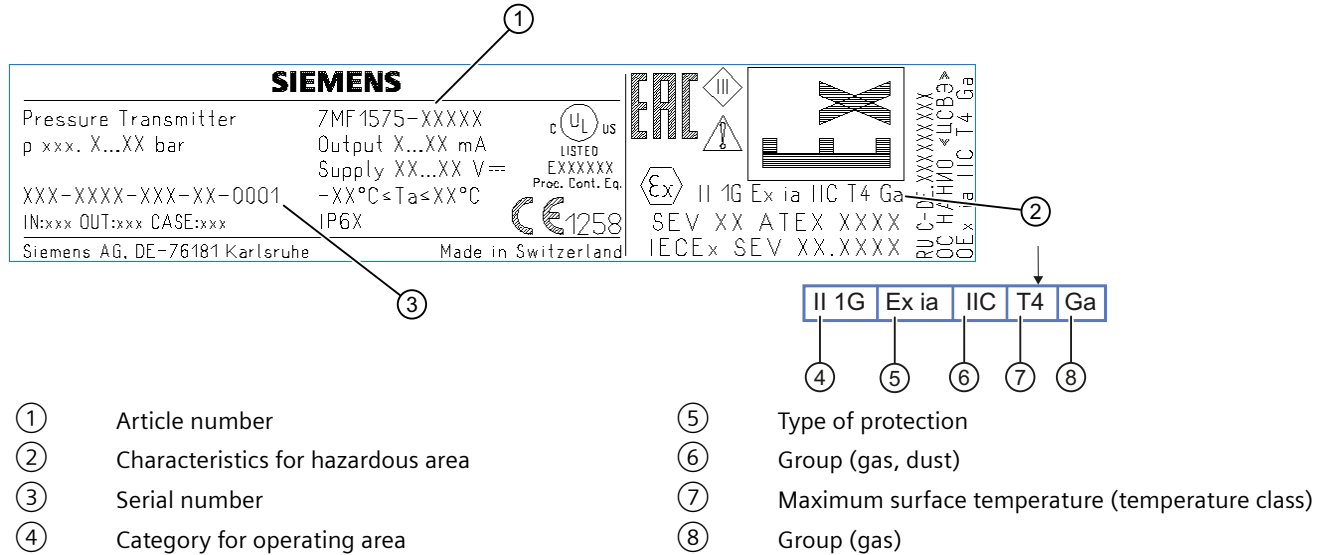

Figure 3-1 Example of a nameplate

The pressure transmitter has a nameplate with the article number and other important information, such as design details and technical specifications.

You must also observe the information in the relevant certificate for a transmitter version for use in hazardous areas.

3.4 Mode of operation

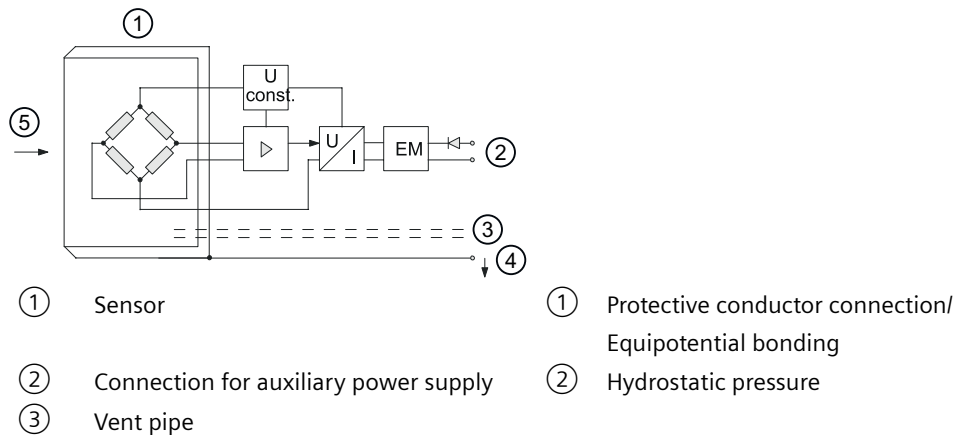

Figure 3-2 Pressure transmitter, mode of operation and wiring diagram

On one side of the sensor ① the diaphragm is exposed to the hydrostatic pressure ⑤, which is proportional to the immersion depth. This pressure is compared with the atmospheric pressure. Pressure compensation is carried out using the vent pipe ③ in the connecting cable.

The hydrostatic pressure of the liquid column acts on the diaphragm of the sensor and transmits the pressure to the Wheatstone resistance bridge in the sensor.

The output voltage signal of the sensor is fed to the electronics, where it is converted into an output current signal of 4 mA to 20 mA.

The protective conductor connection/equipotential bonding ④ is connected to the enclosure.

3.4 Mode of operation

Installing/mounting

4.1 Basic safety instructions

 WARNING**Wetted parts unsuitable for the process media**

Risk of injury or damage to device.

Hot, toxic and corrosive media could be released if the process medium is unsuitable for the wetted parts.

- Ensure that the material of the device parts wetted by the process medium is suitable for the medium. Refer to the information in Technical specifications (Page 29).

Note**Material compatibility**

Siemens can provide you with support concerning selection of sensor components wetted by process media. However, you are responsible for the selection of components. Siemens accepts no liability for faults or failures resulting from incompatible materials.

 WARNING**Exceeded maximum permissible operating pressure**

Risk of injury or poisoning.

The maximum permissible operating pressure depends on the device version, pressure limit and temperature rating. The device can be damaged if the operating pressure is exceeded. Hot, toxic and corrosive process media could be released.

Ensure that maximum permissible operating pressure of the device is not exceeded. Refer to the information on the nameplate and/or in Technical specifications (Page 29).

NOTICE**Using a device with frozen process medium**

Damage to the device through ice formation.

- Prevent ice formation on the pressure transmitter. The process medium must not freeze.

4.1.1 Proper mounting

NOTICE
Incorrect mounting The device can be damaged, destroyed, or its functionality impaired through improper mounting. <ul style="list-style-type: none">• Before installing ensure there is no visible damage to the device.• Make sure that process connectors are clean, and suitable gaskets and glands are used.• Mount the device using suitable tools. Refer to the information in Technical specifications (Page 29).

 CAUTION
Loss of type of protection Damage to device if the enclosure is open or not properly closed. The type of protection specified on the nameplate or in Technical specifications (Page 29) is no longer guaranteed. <ul style="list-style-type: none">• Make sure that the device is securely closed.

See also

Installing/mounting (Page 15)

4.1.2 Use in maritime deployment

Note

In order to meet the flame-retardant requirements of the attached cable, only use type-tested sheathed cables with a cable connection length of ≥ 6 m for a cable length.

4.2 Installation

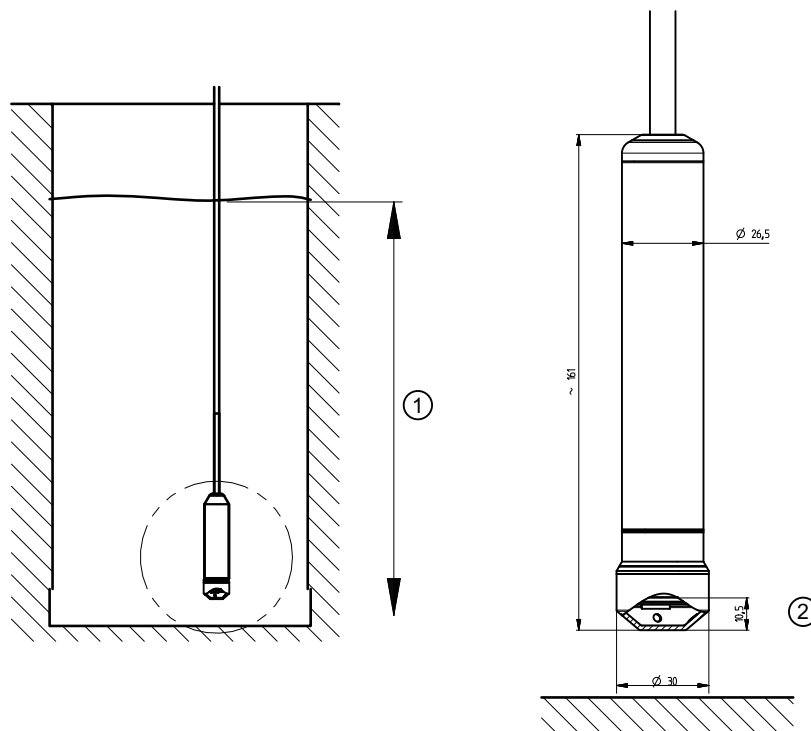

- ① Level
- ② Measurement reference height

Figure 4-1 Mounting the pressure transmitter (example with protective cover made of PPE)

1. Install the pressure transmitter suspended downward on the cable.
2. To prevent measuring errors, fasten the pressure transmitter for moved process media.
3. Fasten the pressure transmitter by means of a guide tube or an additional weight on the transmitter (max. tensile force on connecting cable 360 N).
4. Fasten the cable above the container with the anchor clamp.
5. Connect the cable itself with the cable box.
6. Mount the cable box at a location appropriate to its degree of protection (IP66) in the vicinity of the measuring point.
7. To ensure proper functioning, make sure that the entry openings on the protective cover of the pressure transmitter do not get soiled and that the process medium does not freeze on the pressure transmitter.

4.3 Setting up the measuring points

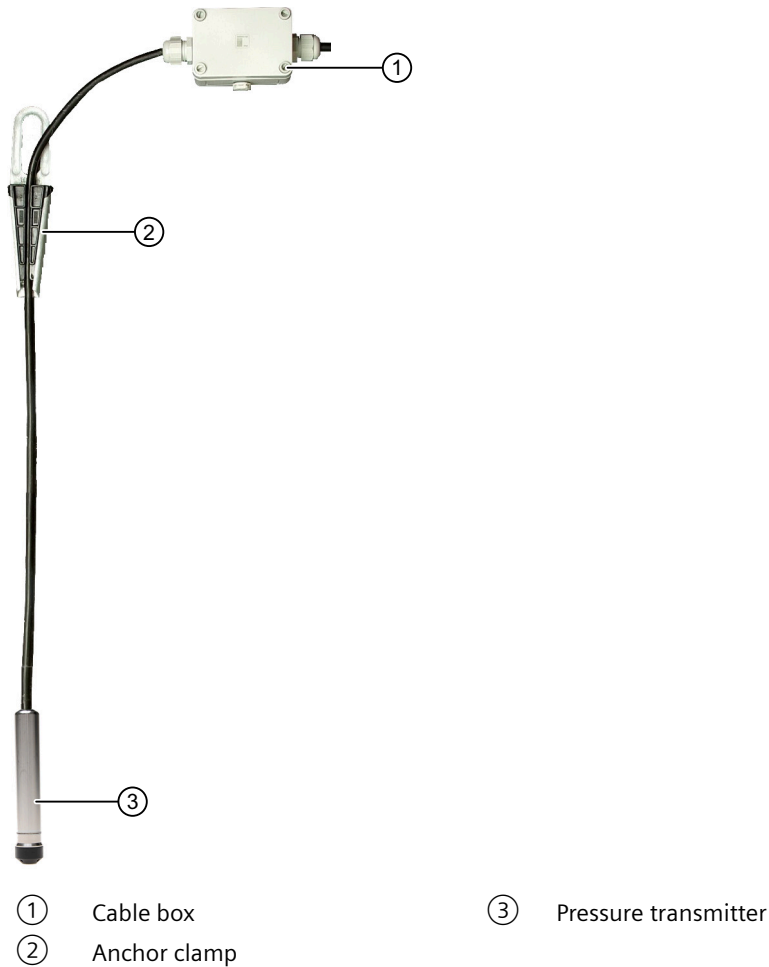

Figure 4-2 Setting up the measuring points

4.4 Establishing the measuring range

Calculating the measuring range with process media with a density $\neq 1000 \text{ kg/m}^3$ (process medium \neq water)

$$p = \rho * g * h$$

with:

ρ = density of the process medium

g = local gravitational acceleration

h = maximum level

Connecting

5.1 Basic safety instructions

 WARNING
<p>Maximum cable length exceeded for devices with type of protection "Intrinsic safety Ex i"</p> <p>Risk of explosion in hazardous areas.</p> <p>To meet the requirements of devices with intrinsic safety "Ex i" type of protection, observe the maximum permissible cable length in section Technical specifications (Page 29).</p>

 WARNING
<p>Unsuitable cables, cable glands and/or plugs</p> <p>Risk of explosion in hazardous areas.</p> <ul style="list-style-type: none"> • Use only cable glands/plugs that comply with the requirements for the relevant type of protection. • Tighten the cable glands in accordance with the torques specified in Technical specifications (Page 29). • Close unused cable inlets for the electrical connections. • When replacing cable, glands use only cable glands of the same type. • After installation, check that the cables are seated firmly.

 WARNING
<p>Improper power supply</p> <p>Risk of explosion in hazardous areas and loss of device safety as a result of incorrect power supply, e.g. using direct current instead of alternating current.</p> <ul style="list-style-type: none"> • Connect the device in accordance with the specified power supply and signal circuits. The relevant specifications can be found in the certificates, in Chapter "Technical specifications (Page 29)" or on the nameplate. • Always power the device with limited energy. Observe the following standards on limited energy: UL61010-1 3rd Edition, Section 9.3 or LPS (Low Power Supply) in accordance with UL60950-1 or Class 2 in accordance with UL1310 or UL1585.

 WARNING
Lack of equipotential bonding Risk of explosion through compensating currents or ignition currents through lack of equipotential bonding. <ul style="list-style-type: none">• Ensure that the device is potentially equalized. Exception: It may be permissible to omit connection of the equipotential bonding for devices with type of protection "Intrinsic safety Ex i".

 WARNING
Unprotected cable ends Risk of explosion through unprotected cable ends in hazardous areas. <ul style="list-style-type: none">• Protect unused cable ends in accordance with IEC/EN 60079-14.

 WARNING
Improper laying of shielded cables Risk of explosion through compensating currents between hazardous area and the non-hazardous area. <ul style="list-style-type: none">• Shielded cables that cross into hazardous areas should be grounded only at one end.• If grounding is required at both ends, use an equipotential bonding conductor.

 WARNING
Connecting device in energized state Risk of explosion in hazardous areas. <ul style="list-style-type: none">• Connect devices in hazardous areas only in a de-energized state. Exceptions: <ul style="list-style-type: none">• Devices having the type of protection "Intrinsic safety Ex i" may also be connected in energized state in hazardous areas.• Exceptions for type of protection "Increased safety ec" (Zone 2) are regulated in the relevant certificate.

Note

Electromagnetic compatibility (EMC)

You can use this device in industrial environments, households and small businesses.

For metal housings there is an increased electromagnetic compatibility compared to high-frequency radiation. This protection can be increased by grounding the housing, see Connecting (Page 19).

Note**Improvement of interference immunity**

- Lay signal cables separately to cables with voltages > 60 V.
- Use cable with twisted wires.
- Keep the device and the cables at a distance from strong electromagnetic fields.

5.2 Connecting the device

Procedure

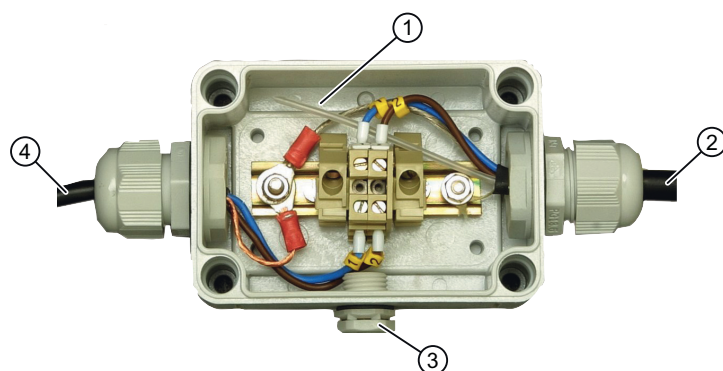

- | | | | |
|---|---------------------------------------|---|---|
| ① | Ventilation pipe or ventilation pipes | ③ | Humidity filter |
| ② | Connection to transmitter | ④ | Connection to measured value processing |

Figure 5-1 Cable box (example for applications in hazardous area)

1. Connect the cable of the pressure transmitter to the terminals as follows:
 - Blue (-)
 - Brown (+)
 - Black (protective conductor connection/potential equalization)
2. Insert the ventilation pipe ① into the cable box.
The ventilation pipe must be connected to the atmosphere. The humidity filter is used for this purpose ③.

Wiring diagram

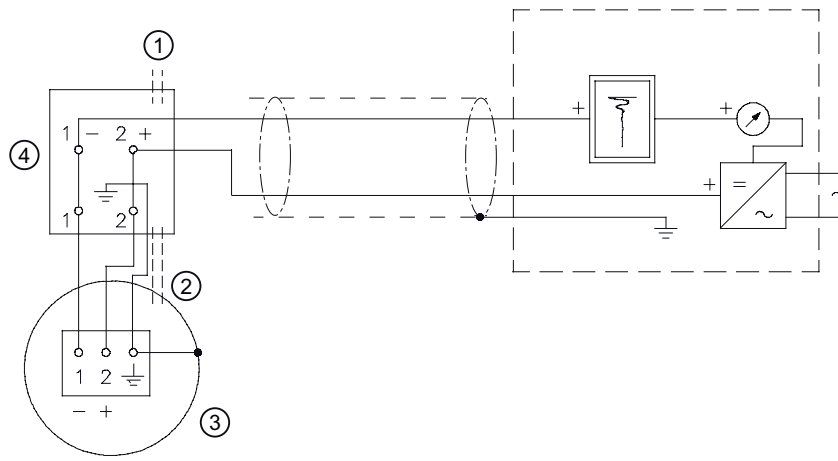

- ① Atmospheric pressure
- ② Vent pipe
- ③ Transmitter
- ④ Cable box

Figure 5-2 Example for applications in hazardous area

Commissioning

6.1 Basic safety instructions



WARNING

Improper commissioning in hazardous areas

Device failure or risk of explosion in hazardous areas.

- Do not commission the device until it has been mounted completely and connected in accordance with the information in Technical specifications (Page 29).
- Before commissioning take the effect on other devices in the system into account.

6.2 Calibrating

The pressure transmitter was calibrated to the measuring range at the manufacturer and cannot be re-calibrated.

Service and maintenance

7.1 Basic safety instructions

Note

The device is maintenance-free.

 WARNING**Impermissible repair of explosion protected devices**

Risk of explosion in hazardous areas

- Repair must be carried out by Siemens authorized personnel only.

 WARNING**Use of a computer in a hazardous area**

If the interface to the computer is used in the hazardous area, there is a risk of explosion.

- Ensure that the atmosphere is explosion-free (hot work permit).

7.2 Calibrating

The pressure transmitter was calibrated to the measuring range at the manufacturer and cannot be re-calibrated.

7.3 Clean diaphragm

If the mediums are contaminated, viscous or crystallized, it could be necessary to clean the diaphragm from time to time. Only remove deposits on the diaphragm using a suitable solvent. Do not use corrosive cleaning agents.

NOTICE**Improper cleaning of diaphragm**

Device damage. The diaphragm can be damaged.

- Do not use sharp or hard objects to clean the diaphragm.

7.4 Maintenance and repair work

 WARNING
Impermissible accessories and spare parts Risk of explosion in areas subject to explosion hazard. <ul style="list-style-type: none">• Only use original accessories or original spare parts.• Observe all relevant installation and safety instructions described in the instructions for the device or enclosed with the accessory or spare part.

NOTICE
Faulty measurement caused by dirt The pressure transmitter can become soiled by the process medium. <ul style="list-style-type: none">• Prevent any dirt accumulating on the entry openings on the protective cover of the pressure transmitter.

7.5 Return procedure

To return a product to Siemens, see Return to Siemens (<https://support.industry.siemens.com/cs/ww/en/sc/3098>).

Contact your Siemens representative to clarify if a product is repairable, and how to return it. They can also help with quick repair processing, a repair cost estimate, or a repair report/ cause of failure report.

NOTICE
Decontamination The product may have to be decontaminated before it is returned. Your Siemens contact person will let you know for which products this is required.

7.6 Disposal

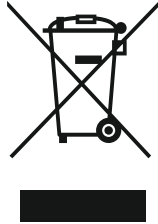

Devices described in this manual should be recycled. They may not be disposed of in the municipal waste disposal services according to the Directive 2012/19/EC on waste electronic and electrical equipment (WEEE).

Devices can be returned to the supplier within the EC and UK, or to a locally approved disposal service for eco-friendly recycling. Observe the specific regulations valid in your country.

Further information about devices containing batteries can be found at: Information on battery/product return (WEEE) (<https://support.industry.siemens.com/cs/document/109479891/>)

Note

Special disposal required

The device includes components that require special disposal.

- Dispose of the device properly and environmentally through a local waste disposal contractor.
-

Technical specifications

Gauge pressure input		
Measured variable	Hydrostatic level	
Measuring range, max. operating pressure (according to 97/23/EC Pressure Equipment Directive) and max. test pressure (according to DIN 16086)	Measuring range	Maximum operating pressure MAWP (PS)
	0 to 0.1 bar	1.5 bar
	0 to 1 mH ₂ O (0 to 3 ftH ₂ O)	15 mH ₂ O (45 ftH ₂ O)
	0 to 0.2 bar	1.5 bar
	0 to 2 mH ₂ O	15 mH ₂ O (45 ftH ₂ O)
	0 to 0.3 bar	1.5 bar
	0 to 3 mH ₂ O (0 to 9 ftH ₂ O)	21.8 psi 15 mH ₂ O (45 ftH ₂ O)
	0 to 0.4 bar	2 bar
	0 to 4 mH ₂ O (0 to 12 ftH ₂ O)	29 psi 20 mH ₂ O (66 ftH ₂ O)
	0 to 0.5 bar	2 bar
	0 to 5 mH ₂ O (0 to 15 ftH ₂ O)	29 psi 20 mH ₂ O (66 ftH ₂ O)
	0 to 0.6 bar	2 bar
	0 to 6 mH ₂ O (0 to 18 ftH ₂ O)	29 psi 20 mH ₂ O (66 ftH ₂ O)
0 to 1 bar	5 bar	
0 to 10 mH ₂ O (0 to 30 ftH ₂ O)	72 psi 51 mH ₂ O (167 ftH ₂ O)	
0 to 2 bar	10 bar	
0 to 20 mH ₂ O (0 to 60 ftH ₂ O)	145 psi 102 mH ₂ O (334 ftH ₂ O)	
0 to 4 bar	20 bar	
0 to 40 mH ₂ O (0 to 120 ftH ₂ O)	204 mH ₂ O (669 ftH ₂ O)	
2-wire output		
Output signal	4 ... 20 mA	
Load	Resistor R [Ω]	
	$R_{\max} = \frac{U_H - 10 \text{ V}}{0,02 \text{ A}}$	
	Rmax is the maximum resistance of the supply line	
U _H	Auxiliary power supply in V	

Measuring accuracy (according to EN 60770-2)

Reference conditions	<ul style="list-style-type: none"> • Rising characteristic curve • Start-of-scale 0 bar • Room temperature 25 °C (77 °F) • Rated voltage 24 V DC
Measurement deviation with limit setting, including hysteresis and for repeatability for measuring range	<p>0.15% of full-scale value (typical)</p> <p>0.3% of full-scale value (maximum)</p>
Effect of ambient temperature	
Zero point and measuring range	0.05% of measuring range per 10K
Long-term stability	
Zero point and measuring range	0.15% of full-scale value/year
Effect of auxiliary power supply	0.01% per 1 V voltage change

Rated conditions

Installation conditions

Ambient conditions

- Ambient temperature -10 ... +80 °C (-4 ... +176 °F)
 - Altitude Max. 2 000 m above sea level
 - Relative humidity 0 to 100%

Note Observe the temperature class in hazardous areas.

Storage temperature -20 to +80 °C (-4 to +176 °F)

- Degree of protection according to EN 60529 IP68
- Electromagnetic compatibility

Interference emission and interference immunity To EN 61326-1 and EN 61326-2-3

Process medium conditions

- Process medium temperature -10 ... +80 °C (-4 ... +176 °F)

Pressure transmitter construction

Weight

- Pressure transmitter Approx. 0.4 kg (0.88 lb)
- Cable 0.08 kg/m (approx. 0.059 lb/ft)

Material

- Wetted parts materials

Housing Stainless steel material No. 1.4404/316L or 1.4539/904L

Sensor Ceramic Al₂O₃ (99.6%)

Pressure transmitter construction

Cable	PE-HD, FEP
Protective cover	PPE, ETFE, stainless steel (1.4404/316L or 1.4539/904L)
Sealing material	FPM, EPDM (for drinking water)
Electrical connection	Lengths: 3, 5, 10, 15, 20, 30, 40, 50, ..., 1000 m The maximum permissible cable length for devices with type of protection "Intrinsic safety Ex i" is 300 m.
Torque for cable gland nut made of	Plastic 2.5 Nm (1.8 ft lb)



Cable box 7MF1575-8AA construction (accessory)

Field of application	For connecting the transmitter cable
Weight	0.2 kg (0.44 lb)
Electrical connection	2 x 3-way (cable diameter from 1 mm ² to 1.5 mm ²)
Cable entry	2 x Pg 13.5
Enclosure material	Polycarbonate
Vent pipe for atmospheric pressure	
Screw for bearer wire	
Torque for cable gland nut made of	Plastic 2.5 Nm (1.8 ft lb)
Rated conditions	
<ul style="list-style-type: none"> Degree of protection according to EN 60 529 	IP65

Anchor clamp 7MF1575-8AB construction (accessory)

Field of application	For fastening the transmitter
Weight	0.16 kg (0.35 lb)
Electrical connection	Galvanized steel, polyamide

Auxiliary power U_H

Terminal voltage at transmitter	 10 V DC to 30 V DC  10 V DC to 33 V DC 
Current consumption	< 20.5 mA
Reverse polarity protection	Yes

8.1 Certificates and approvals

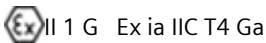
Certificates and approvals	
Drinking water (ACS)	17 ACC NY 055
Drinking water (WRAS)	Available soon
Drinking water (DVGW/ KTW W270)	Available soon
EAC	TC N RU Д-ГА02.В.05092
Underwriters Laboratories (UL)	ML File No. E344532, issued 2017-08-17
Shipbuilding	Available soon
• DNV/GL	
• LR	
• BV	
• ABS	
Explosion protection	ATEX (SEV 16 ATEX 0121) IEC Ex (IEC Ex SEV 16.0003) EAC Ex (TC RU C-Д.АА87.В.00324) CML 22 UKEX 2171
• Intrinsic safety "i" Marking	
Connection	To certified intrinsically safe circuit with the max. values: U _i = 30 V, I _i = 100 mA, P _i = 750 mW
Effective internal capacitance	C _i = 2 nF + 0.204 nF (per meter supply line on the pressure transmitter)
Effective internal inductance	L _i = 8 μH + 1.48 μH (per meter supply line on the pressure transmitter)

Dimension drawings

Pressure transmitter

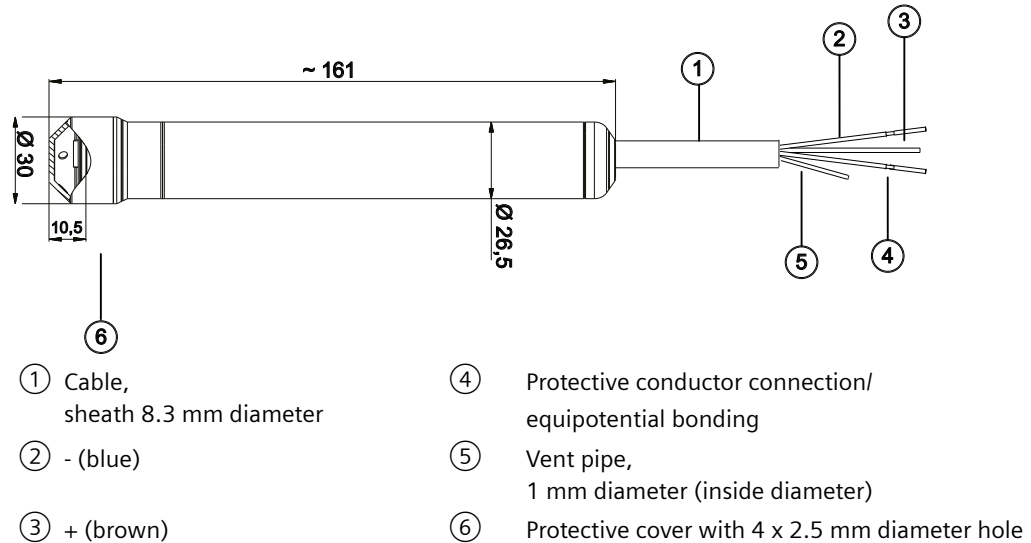

Figure 9-1 Pressure transmitter with protective cover made of PPE/ETFE, dimensions in mm

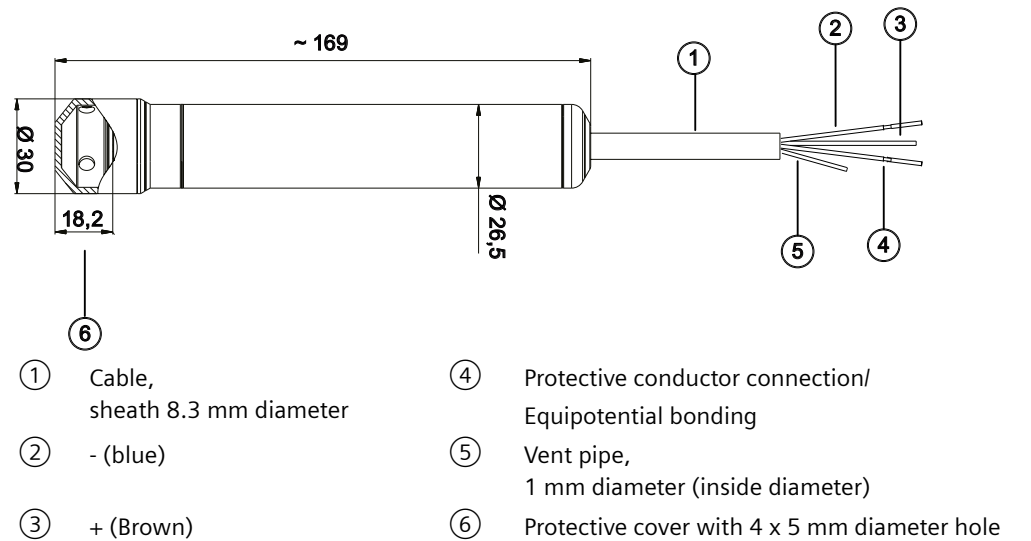

Figure 9-2 Pressure transmitter with protective cover made of stainless steel, dimensions in mm

Cable box

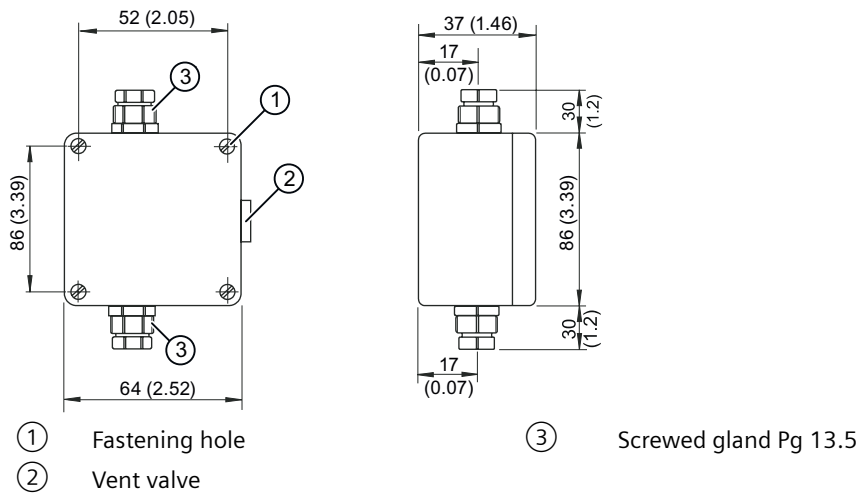
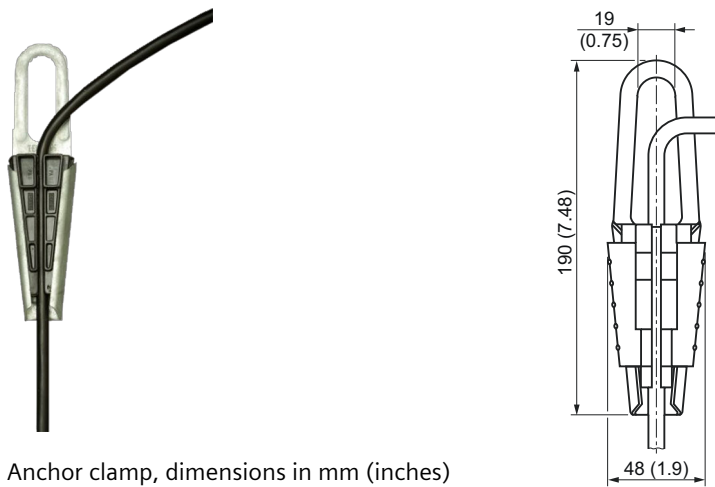

Figure 9-3 Cable box, dimensions in mm (inches)

Anchor clamp



Anchor clamp, dimensions in mm (inches)

Product documentation and support

A.1 Product documentation

Process instrumentation product documentation is available in the following formats:

- Certificates (<http://www.siemens.com/processinstrumentation/certificates>)
- Downloads (firmware, EDDs, software) (<http://www.siemens.com/processinstrumentation/downloads>)
- Catalog and catalog sheets (<http://www.siemens.com/processinstrumentation/catalogs>)
- Manuals (<http://www.siemens.com/processinstrumentation/documentation>)
You have the option to show, open, save, or configure the manual.
 - "Display": Open the manual in HTML5 format
 - "Configure": Register and configure the documentation specific to your plant
 - "Download": Open or save the manual in PDF format
 - "Download as html5, only PC": Open or save the manual in the HTML5 view on your PC

You can also find manuals with the Mobile app at Industry Online Support (<https://support.industry.siemens.com/cs/ww/de/sc/2067>). Download the app to your mobile device and scan the device QR code.

Product documentation by serial number

Using the PIA Life Cycle Portal, you can access the serial number-specific product information including technical specifications, spare parts, calibration data, or factory certificates.

Entering a serial number

1. Open the PIA Life Cycle Portal (<https://www.pia-portal.automation.siemens.com>).
2. Select the desired language.
3. Enter the serial number of your device. The product documentation relevant for your device is displayed and can be downloaded.

To display factory certificates, if available, log in to the PIA Life Cycle Portal using your login or register.

Scanning a QR code

1. Scan the QR code on your device with a mobile device.
2. Click "PIA Portal".

To display factory certificates, if available, log in to the PIA Life Cycle Portal using your login or register.

A.2 Technical support

Technical support

If this documentation does not completely answer your technical questions, you can enter a Support Request (<http://www.siemens.com/automation/support-request>).

For help creating a support request, view this video here (www.siemens.com/opensr).

Additional information on our technical support can be found at Technical Support (<http://www.siemens.com/automation/csi/service>).

Service & support on the Internet

In addition to our technical support, Siemens offers comprehensive online services at Service & Support (<http://www.siemens.com/automation/serviceandsupport>).

Contact

If you have further questions about the device, contact your local Siemens representative at Personal Contact (<http://www.automation.siemens.com/partner>).

To find the contact for your product, go to "all products and branches" and select "Products & Services > Industrial automation > Process instrumentation".

Contact address for business unit:

Siemens AG
Digital Industries
Process Automation
Östliche Rheinbrückenstr. 50
76187 Karlsruhe, Germany

Index

C

Catalog
 catalog sheets, 35
Certificates, 7, 35
Conformity with UK directives, 8
Correct usage, (See improper device modifications)
Customer Support, (Refer to Technical support)

D

Disposal, 27
Downloads, 35

H

Hazardous area
 Laws and directives, 7
 Qualified personnel, 9
Hotline, (Refer to Support request)

I

Improper device modifications, 8

L

Laws and directives
 Disassembly, 7
 Personell, 7

M

Manuals, 35

N

Nameplate, 12

Q

Qualified personnel, 9

R

Return procedure, 26

S

Scope of delivery, 5
Service, 36
Service and support
 Internet, 36
Support, 36
Support request, 36

T

Technical support, 36
 partner, 36
 personal contact, 36
Test certificates, 7

W

Warranty, 6

