

Teledyne Isco Non-Contact LaserFlow™ Velocity Sensor

The LaserFlow™ velocity sensor remotely measures flow in open channels with non-contact Laser Doppler Velocity technology and non-contact Ultrasonic Level technology. The sensor uses advanced technology to measure velocity with a laser beam at single or multiple points below the surface of the wastewater stream. (*Patented*)

The sensor uses an ultrasonic level sensor to measure the level and determines a sub-surface point to measure velocity. The sensor then focuses its laser beam at this point and measures the frequency shift of the returned light.

The LaserFlow is ideal for a broad range of wastewater monitoring applications. It is compatible with both the Teledyne Isco Signature® Flow Meter and the Teledyne Isco 2160 LaserFlow Module, depending on the type of installation.

During submerged conditions, flow measurement continues without interruption with optional continuous wave Doppler Ultrasonic Area Velocity technology.

With its specially designed mounting bracket in place, the LaserFlow can be deployed and removed from street level. This avoids the risk and expense of confined space entry. A variety of communication options enable programming and data retrieval from a remote location. Information about data quality can be recorded and transmitted with the flow data.

Additionally, built-in diagnostic tools simplify installation, maintenance, and advanced communication options reduce site visits.

Applications

- Permanent and portable flow measurement for CSO, SSO, I&I, SSEs, CMOM, and other sewer monitoring programs
- Shallow flow measurement in varying pipe sizes
- Wastewater treatment plant influent, process, and effluent flow measurement
- Industrial process and discharge flow measurement
- Stormwater conveyance and outfall
- Irrigation canals and channels



Standard Features

- Non-contact velocity and level measurement
- Single or Multiple Point measurement below the liquid surface
- Rugged, submersible enclosure with IP68 ingress protection
- Zero deadband from measurement point in non-contact level and velocity measurements
- Quality readings without manual profiling
- Bidirectional velocity measurement

Options and Accessories

- Flow measurement during submerged conditions via Ultrasonic Doppler technology
- Redundant flow measurement with simultaneous Continuous Wave Doppler or Ultrasonic Level Sensing
- Permanent and temporary mounting hardware
- Sensor retrieval arm enables installation and removal without confined space entry
- Remote ultrasonic level sensor options for drop manhole and outfall applications



System Versatility

From industrial applications to manhole installations, the LaserFlow offers versatile configuration options to give you the flexibility to measure flow in most open channel applications. The sensor is compatible with both the Signature flow meter for permanent discharge compliance monitoring, and the 2160 module for everything from portable surveys to permanent installations. Both flow meters have a variety of communication options for remote data access and programming, eliminating the need for frequent site visits.

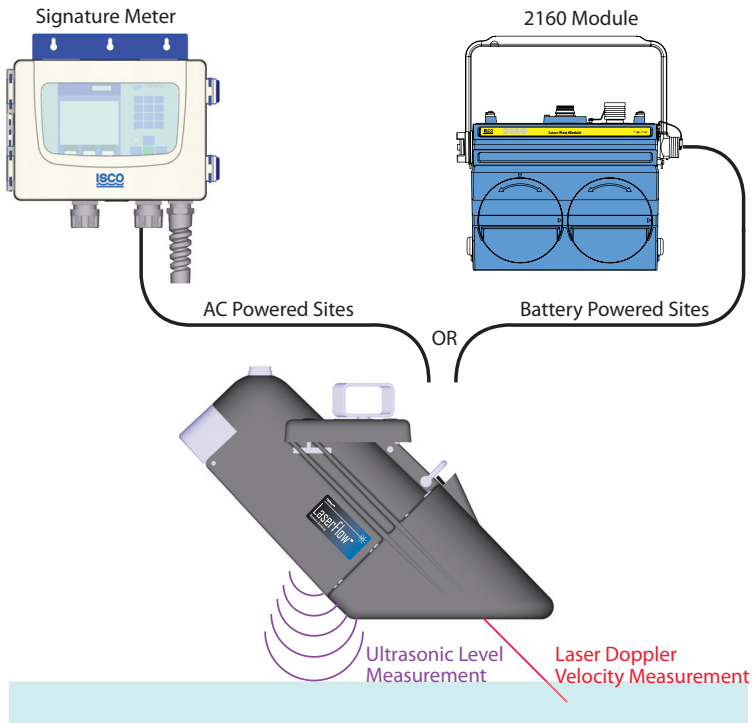

Single or Multipoint Measurement

Depending on your application needs, the LaserFlow device can be programmed to take velocity measurements at single or multiple points below the water's surface, producing an accurate mean velocity reading.

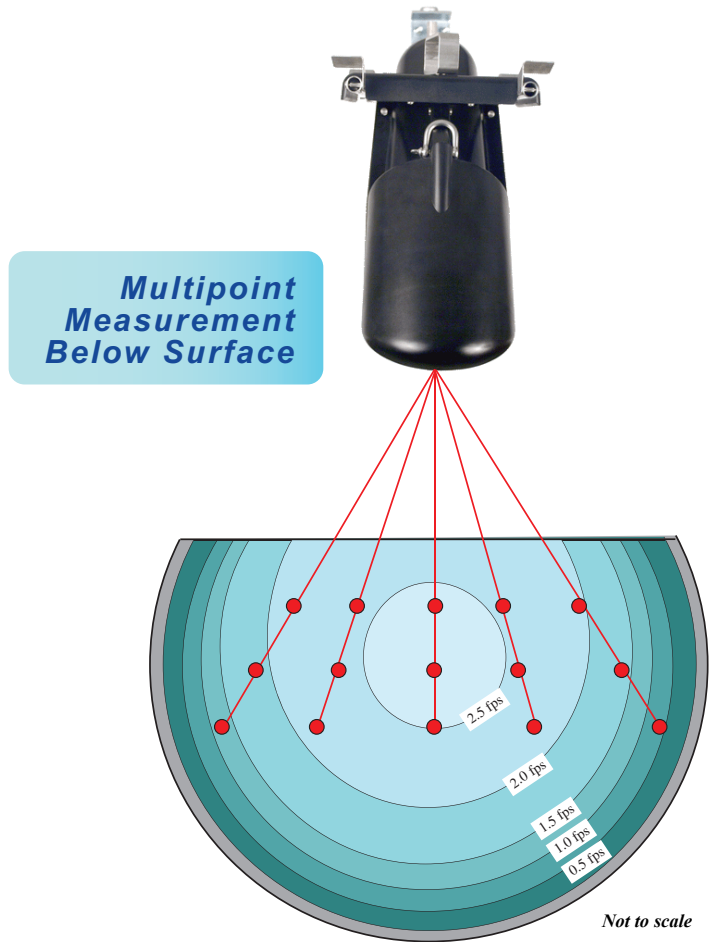

Remote Ultrasonic Option

In applications where the level measurement point of the built-in ultrasonic and the measurement point of the laser velocity are of different elevations, such as a free-falling outfall or drop manhole, the remote ultrasonic option can be used so that both measurement points reference the same elevation.

Due to unique site requirements, various mounting hardware is available for use with the LaserFlow sensor and 310 remote ultrasonic sensor.

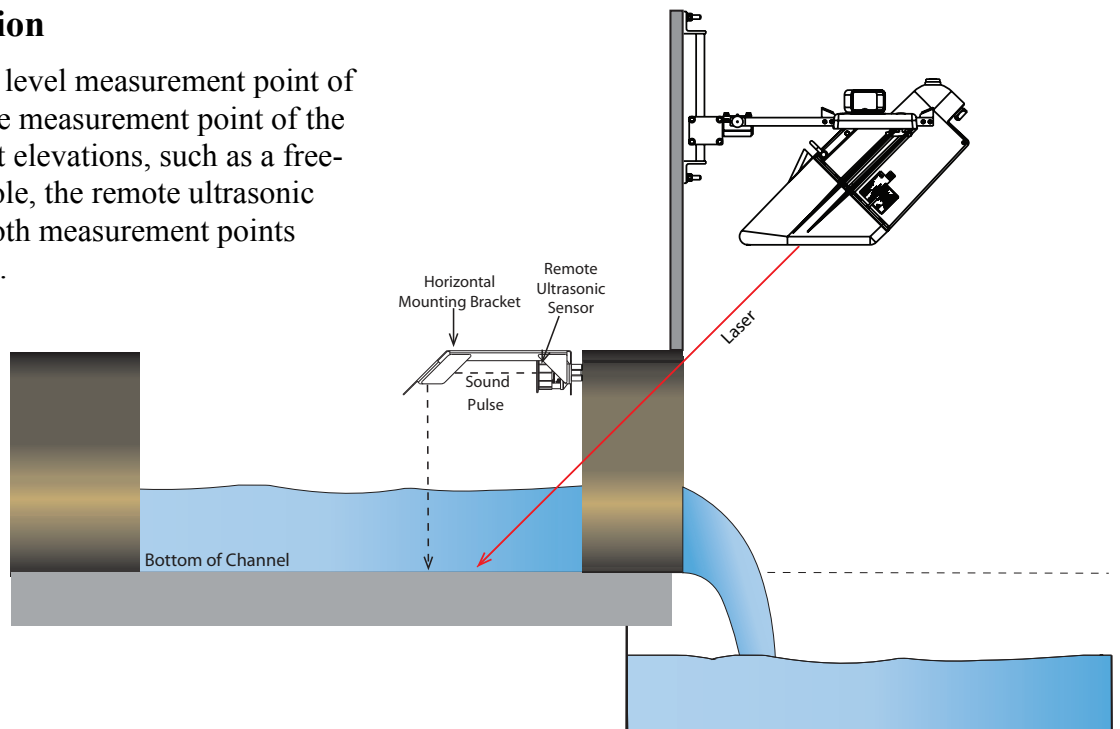

Optional Submerged Functionality

During submerged conditions, when water reaches the LaserFlow, the optional bottom-mounted TIENet™ 350 Area Velocity sensor seamlessly takes over the flow rate measurement. The sensor provides ultrasonic Doppler velocity measurement and Differential Pressure level measurement.

This option measures flow in the pipe/channel. By measuring velocity over a large area, the ultrasonic Doppler technology provides more accurate flow measurement during submerged conditions.

Optional Redundant Measurement

For redundant flow measurement at critical monitoring sites, a unique flexibility is added by the optional 350 sensor when mounted at the bottom of the pipe.

This sensor provides redundant velocity, level, and flow data from the same site as the LaserFlow device.

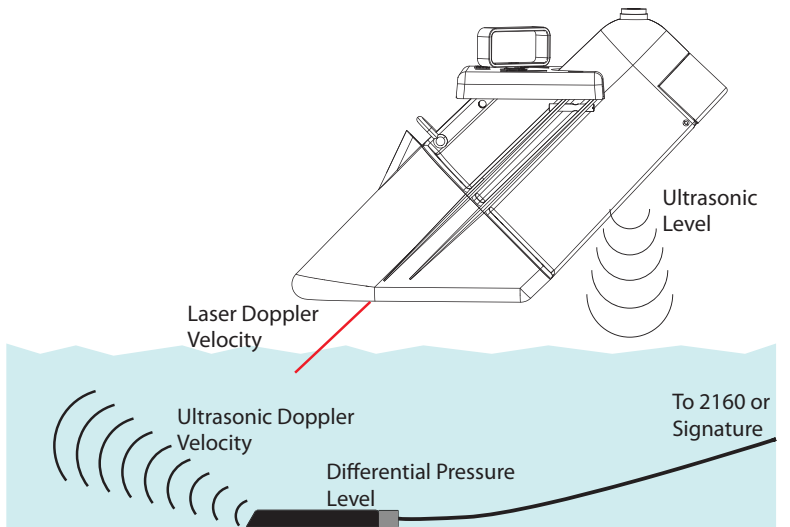
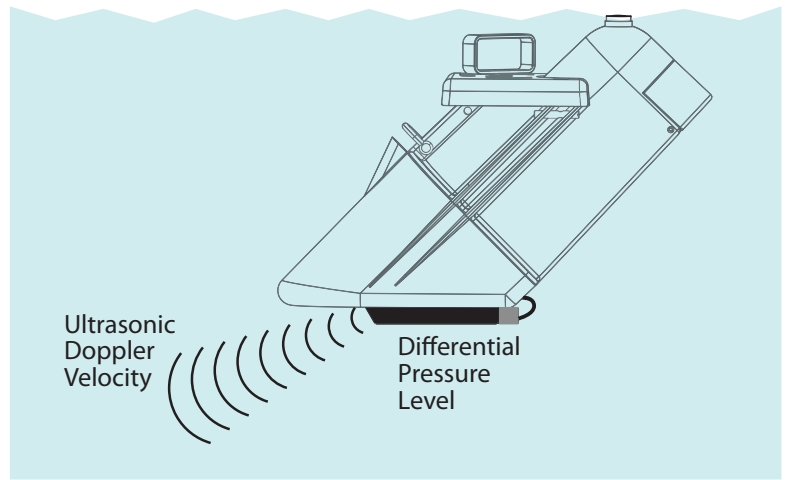

Easy and Secure Retrieval/Replacement Without Manhole Entry

Following initial installation and adjustment, the sensor can be installed or removed as needed without manhole entry in most situations, using the optional sensor retrieval arm (shown at left) to grasp the handle.

The handle's simple yet effective locking mechanism (shown below) holds the sensor securely in place, and is easy to engage and release from above ground.



Primary Measurement:^a TIENet™ 360 LaserFlow™ Sensor	
Size (H x W x D)	38.01 x 26.21 x 56.7 cm (14.96 x 10.3 x 22.32 in)
Weight	8.7 kg (19.2 lbs)
Materials	Conductive Carbon Filled ABS, SST, Conductive Kynar® ^b , Anodized Aluminum, UV Rated PVC
Cable Lengths	10 or 23 m (32.8 or 75.5 ft) ^c
Enclosure	IP68
Certifications	CE EN61326; FDA CDRH 21CFR1040; IEC 60825-1
Laser Class	Class 3R
Temperature Range	Operating: -20 to 60 °C (-4 to 140 °F) Storage: -40 to 60 °C (-40 to 140 °F)
Power Required	Input voltage: 8 to 26 VDC 12 VDC Nominal
Flow Accuracy	±4% of reading ^d
Velocity	
Technology	Non-Contact, Subsurface Laser Doppler Velocity (patent pending)
Measurement Range	-4.6 m/s to 4.6 m/s (-15 ft/s to 15 ft/s)
Maximum distance from liquid surface to bottom of sensor	3 m (10 ft)
Minimum depth	0.01 m (0.5 in) ^d
Direction	Selectable Bidirectional Measurement ^e
Accuracy	±0.5% of reading ±0.03 m/s (0.1 ft/s)
Minimum Velocity	0.15 m/s (0.5 ft/s)
Level	
Technology	Non-Contact Ultrasonic
Measurement Range	0 to 3 m (0 to 10 ft) from measurement point
Accuracy @ 22 °C (72 °F)	±0.006 m (0.02 ft) at ≤1 ft level change ±0.012 m (0.04 ft) at >1 ft level change
Temperature Coefficient within compensated range	± 0.0002 x D (m) per degree C ± 0.00011 x D (ft) per degree F (D = Distance from transducer to liquid surface)
Beam Angle	10° (5° from center line)
Ultrasonic Signal	50 KHz
Deadband	Zero deadband from bottom of LaserFlow sensor ^f

Optional Secondary Measurement: TIENet™ 350 Area Velocity Sensor	
Probe Size (H x W x L)	19 x 33 x 152 mm (0.75 x 1.3 x 6.0 in)
Materials	Sensor: Epoxy, chlorinated CPVC, SST Cable: UV-Rated PVC
Certifications	CE EN61326
Temperature Range	0 to 70 °C (32 to 158 °F)
Velocity	
Technology	Submerged Continuous Wave Doppler Ultrasonic
Measurement Range	-1.5 to 6.1 m/s (-5 to 20 ft/s)
Velocity Measurement	Bidirectional
Accuracy	±0.03 m/s (±0.1 ft/s) from -5 to 5 ft/s ±2% of reading from 5 to 20 ft/s, Uniform velocity profile
Minimum Depth	25 mm (0.08 ft)
Frequency	500 kHz
Level	
Technology	Submerged Differential Linear Pressure Transducer
Measurement Range	0.01 to 3.05 m (0.033 to 10 ft)
Accuracy	± 0.10% of full scale
Maximum Depth	10.5 m (34 ft)
Stability	±0.007 m/yr (±0.023 ft/yr)

- a. All specifications are subject to change without notice.
b. Kynar® is a registered trademark of Arkema, Inc.
c. Custom cable lengths also available.
d. Under normal flow conditions.
e. Turbidity > 20 NTU. Distance < 48 inches.
f. Deadband for remote TIENet™ 310 ultrasonic level sensor varies, depending on the type of mounting hardware.



4700 Superior Street
Lincoln, NE 68504 USA
Tel: (402) 464-0231

USA and Canada (800) 228-4373
Fax: (402) 465-3022
E-Mail: lscinfo@teledyne.com

Teledyne Isco reserves the right to change specifications without notice.
©2012 Teledyne Isco L-2153 04/14

