

Solar Radiation Shield (RS3-B)



Items included:

- One assembled solar radiation shield
- One mounting bracket
- Six cable ties
- Two knurled nuts or wingnuts
- Two screws
- One hose clamp

Specifications

Wind Resistance	Tested in sustained winds up to 129 kph (80 mph) Tested in gusts up to 161 kph (100 mph)
Materials	Shield: ASA styrene (UV-stable) Bracket: Glass-filled nylon (UV-stable) Mounting hardware: Stainless steel and brass
Temperature	-40° to 75°C (-40° to 167°F)
Weight	113 g (4 oz)
Height	89 mm (3.5 inches); 159 mm (6.25 inches) with bracket
Diameter	102 mm (4 inches); bracket protrudes an additional 102 mm (4 inches) from shield
Mounting	Up to 51 mm (2 inches) mast diameter with hose clamp; unlimited with screws
Compatible Sensors	S-THB-00x, S-TMB-M0xx, RXW-THC-xxx, RXW-TMB-xxx, TMCx-HD, and external sensors from U23-00x or MX230x
Maximum Sensor Diameter	1.22 cm (0.48 inches)

Mount temperature or temp/RH sensor in shield as shown. Clearance between mounting bracket and radiation shield ceiling is 65 mm (2.5 in.). Measure the sensor's placement accordingly and secure the cable to the mounting bracket (C) with cable ties (B). Carefully place the radiation shield (A) over the sensor and attach to mounting bracket with knurled nuts or wingnuts (D), being careful not to over-tighten.

Attach mounting bracket to wall, post, or station mast. To use included screws (E) as shown in the diagram on the left, pre-drill 2.4 mm (3/32 in.) holes in wood, or 2.75 mm (7/64 in.) holes in metal.

Or, fasten with hose clamp (F) as shown in diagram on the right.

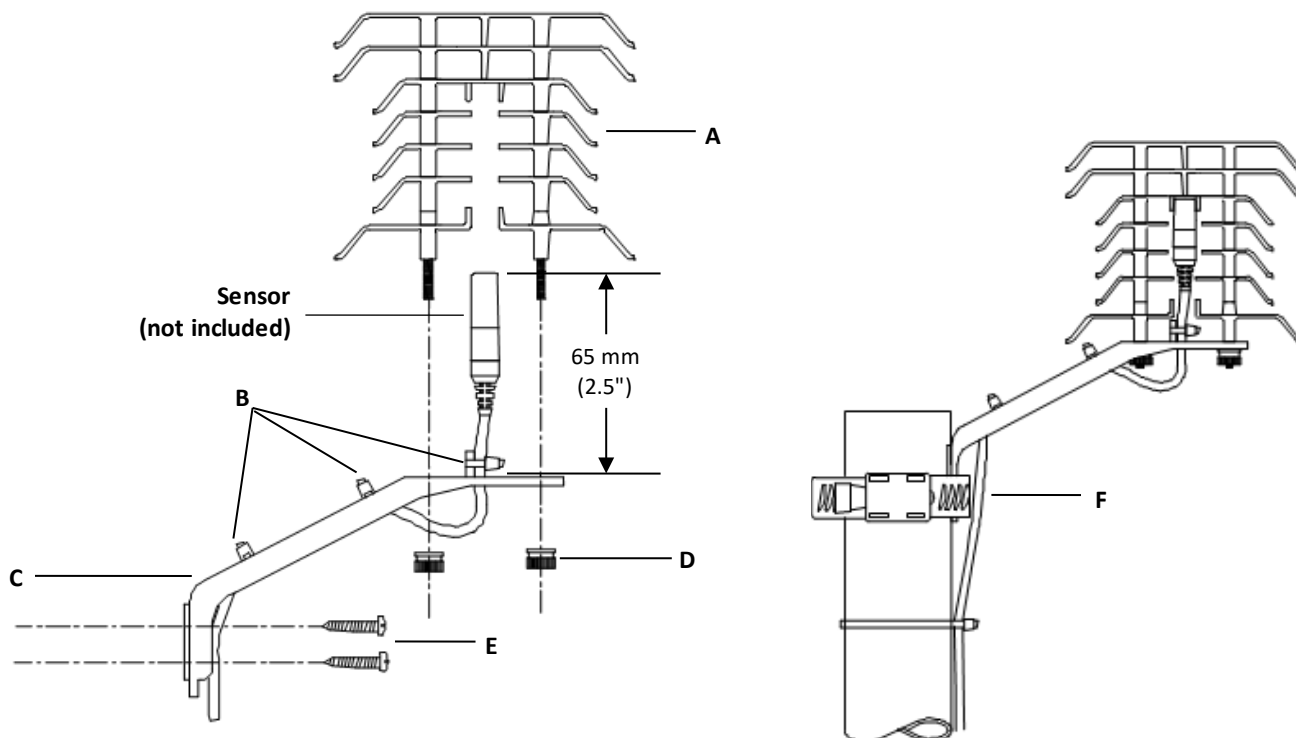

Note: This shield does not protect sensors from light reflected from below the shield at some angles. Avoid deploying this shield next to reflective surfaces if possible.